

Structural Calculations

For

Dann Residence

3008 70th Avenue SE, Mercer Island, WA 98040

October 1, 2024



Prepared by

Brian Lampe
Mariam Soliman

STRUCTURAL CALCULATIONS SHEET INDEX
Dann Residence
3008 70th Avenue SE, Mercer Island, WA 98040

<u>Item</u>	<u>Page #</u>
Criteria	
• Design Criteria.....	C1.1
Gravity	
• Roof Framing	
✓ Key Plans	R1.1
✓ Beams	R2.1
• Upper Floor Framing	
✓ Key Plans	U1.1
✓ Beams	U2.1
• Main Floor Framing	
✓ Key Plans	MF1.1
✓ Beams	MF2.1
Lateral	
• Forces	
✓ Criteria	L1.1
✓ Building Geometry	L1.2
✓ Seismic Parameters	L1.3
✓ Wind Lateral Loads.....	L1.4
✓ Vertical Distribution of Lateral Forces	L1.5
• Shear Walls/Diaphragms	
✓ Roof Diaphragm Forces/ Upper Floor Diaphragm Forces	L2.1
✓ Shear Wall Forces	L2.2
✓ Shear Wall Analysis.....	L2.3
• Shear Wall/Diaphragm Capacities	
✓ Allowable Diaphragm Stresses.....	L3.1
✓ Allowable Shear Wall Stresses.....	L3.2
✓ Shear Wall Anchor Bolts	L3.3
✓ Shear Wall Schedule.....	L3.4
Miscellaneous	
• Stud Wall Design.....	M1.1
• Post Design	M1.3
• Footing Design	M2.1

BTL

ENGINEERING

19011 Wood-Sno Road NE, Suite 100

Woodinville, WA 98072-4436

Phone: (425) 814-8448

Fax: (425) 821-2120

Criteria



Project: Dann Residence
Project Number: 3008 70th Avenue SE, Mercer Island, WA 98040

Code:	IBC 2018		
	Risk Category	II	
Earthquake:	Site Class	D	
		$I_e = 1.00$	$R = 6.5$
		$S_S = 1.405$	$\Omega_0 = 3.0$
		$S_1 = 0.489$	$C_d = 4.0$
		$\rho = 1.00$	
Wind:	Basic Design Wind Speed, V	110	
	Exposure	B	
	Topographic Factor	$K_{ZT} = 1.60$	
Soil Bearing:	1500-psf Allowable Soil Bearing Pressure		
Concrete:	2500-psi Concrete Strength		
	Higher strength may be used, but special inspection and testing reports not req'd		
Nails:	Sheathing	8d common (2½" x 0.131")	
	Framing	12d box (3¼" x 0.131")	
Roof Framing:			
<i>Snow Load</i>	Ground Snow, P_g		25 psf
		Exposure factor, C_e	1.0
		Thermal Factor, C_t	1.2
	Flat Roof Snow, P_f (0.7 $C_e C_t I P_g$)		21 psf
	Use Snow Load		25 psf
	Attic (where accessible)		10 psf
<i>Dead Load</i>	Roofing - Composition Shingles		4.0 psf
	Sheathing - 7/16 OSB		2.2 psf
	Framing - Trusses @ 24"oc		2.5 psf
	Insulation - Batt.		1.0 psf
	Ceiling - 5/8 GWB		2.8 psf
	Misc.		2.5 psf
		Total	15 psf
<i>Deflection</i>	L/360 Live Load, L/240 Total Load		
Floor Framing:			
<i>Live Load</i>	Residential		40 psf
	Decks		60 psf
<i>Dead Load</i>	Finish Floor - Carpet/Vinyl		5.0 psf
	Sheathing - 3/4 Plywood/Edge Gold		2.5 psf
	Framing - I-Joists @ 16"oc		2.7 psf
	Ceiling - 5/8 GWB		2.8 psf
	Misc.		2.0 psf
		Total	15 psf
<i>Deflection</i>	L/480 Live Load, L/240 Total Load		
Wall Framing:			
<i>Dead Load</i>	Exterior 2x Stud Walls		10 psf
	Interior 2x Stud Walls		8 psf

⚠ This is a beta release of the new ATC Hazards by Location website. Please [contact us](#) with feedback.

📌 The ATC Hazards by Location website will not be updated to support ASCE 7-22. [Find out why.](#)

ATC Hazards by Location

Search Information

Address: 3008 70th Ave SE, Mercer Island, WA 98040, USA
Coordinates: 47.5834996, -122.2449016
Elevation: 290 ft
Timestamp: 2024-01-26T15:18:30.091Z
Hazard Type: Seismic
Reference Document: ASCE7-16
Risk Category: II
Site Class: D-default



Basic Parameters

Name	Value	Description
S_S	1.405	MCE_R ground motion (period=0.2s)
S_1	0.489	MCE_R ground motion (period=1.0s)
S_{MS}	1.685	Site-modified spectral acceleration value
S_{M1}	* null	Site-modified spectral acceleration value
S_{DS}	1.124	Numeric seismic design value at 0.2s SA
S_{D1}	* null	Numeric seismic design value at 1.0s SA

* See Section 11.4.8

Additional Information

Name	Value	Description
SDC	* null	Seismic design category
F_a	1.2	Site amplification factor at 0.2s
F_v	* null	Site amplification factor at 1.0s
CR_S	0.902	Coefficient of risk (0.2s)
CR_1	0.896	Coefficient of risk (1.0s)
PGA	0.601	MCE_G peak ground acceleration
F_{PGA}	1.2	Site amplification factor at PGA
PGA_M	0.721	Site modified peak ground acceleration
T_L	6	Long-period transition period (s)
$SsRT$	1.405	Probabilistic risk-targeted ground motion (0.2s)
$SsUH$	1.557	Factored uniform-hazard spectral acceleration (2% probability of exceedance in 50 years)
SsD	3.305	Factored deterministic acceleration value (0.2s)
$S1RT$	0.489	Probabilistic risk-targeted ground motion (1.0s)
$S1UH$	0.545	Factored uniform-hazard spectral acceleration (2% probability of exceedance in 50 years)
$S1D$	1.342	Factored deterministic acceleration value (1.0s)
$PGAd$	1.138	Factored deterministic acceleration value (PGA)

* See Section 11.4.8

The results indicated here DO NOT reflect any state or local amendments to the values or any delineation lines made during the building code adoption process. Users should confirm any output obtained from this tool with the local Authority Having Jurisdiction before proceeding with design.

King County iMap

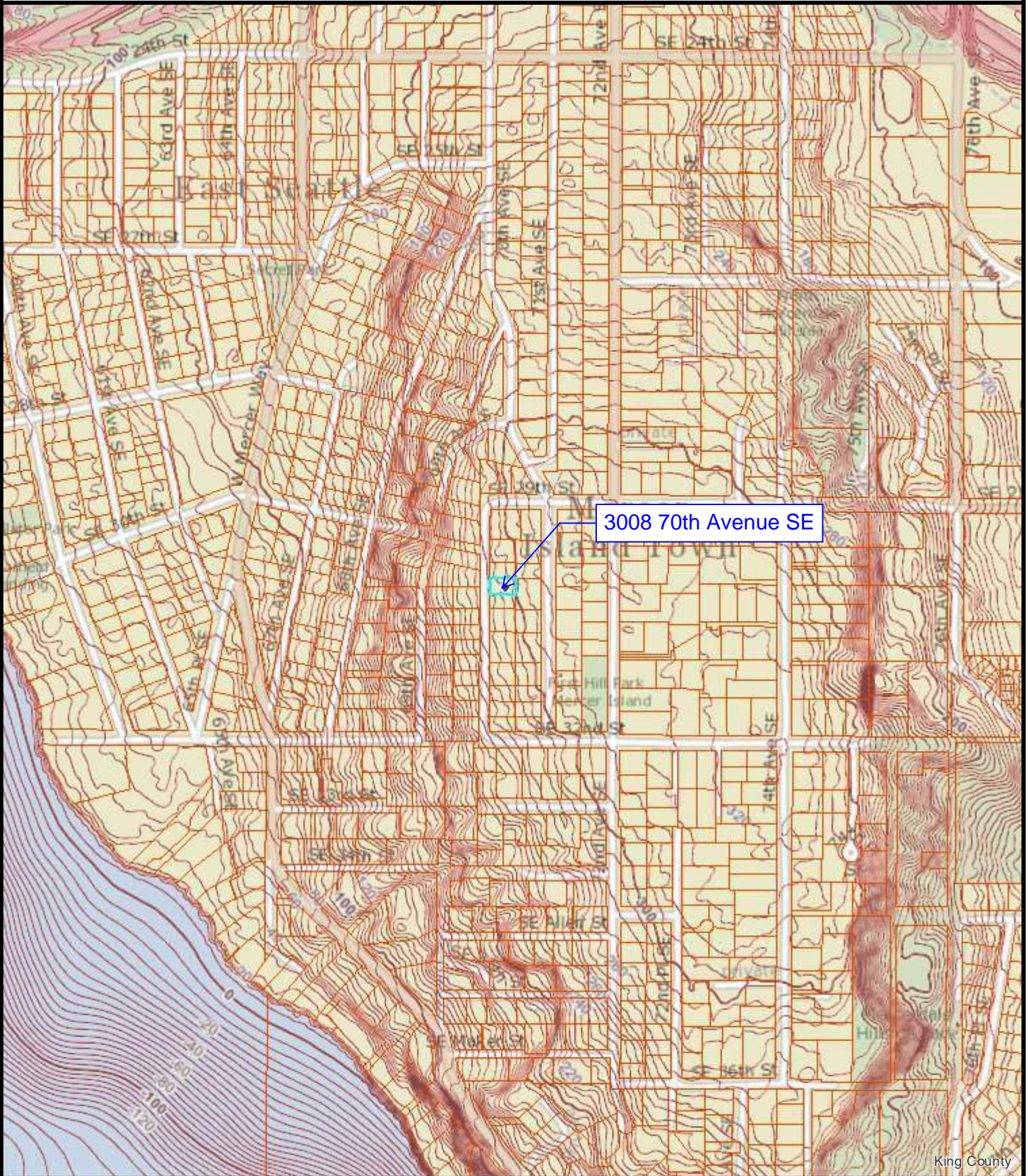

3008 70th Avenue SE

The information included on this map has been compiled by King County staff from a variety of sources and is subject to change without notice. King County makes no representations or warranties, express or implied, as to accuracy, completeness, timeliness, or rights to the use of such information. This document is not intended for use as a survey product. King County shall not be liable for any general, special, indirect, incidental, or consequential damages including, but not limited to, lost revenues or lost profits resulting from the use or misuse of the information contained on this map. Any sale of this map or information on this map is prohibited except by written permission of King County.

Date: 3/25/2024

Notes:





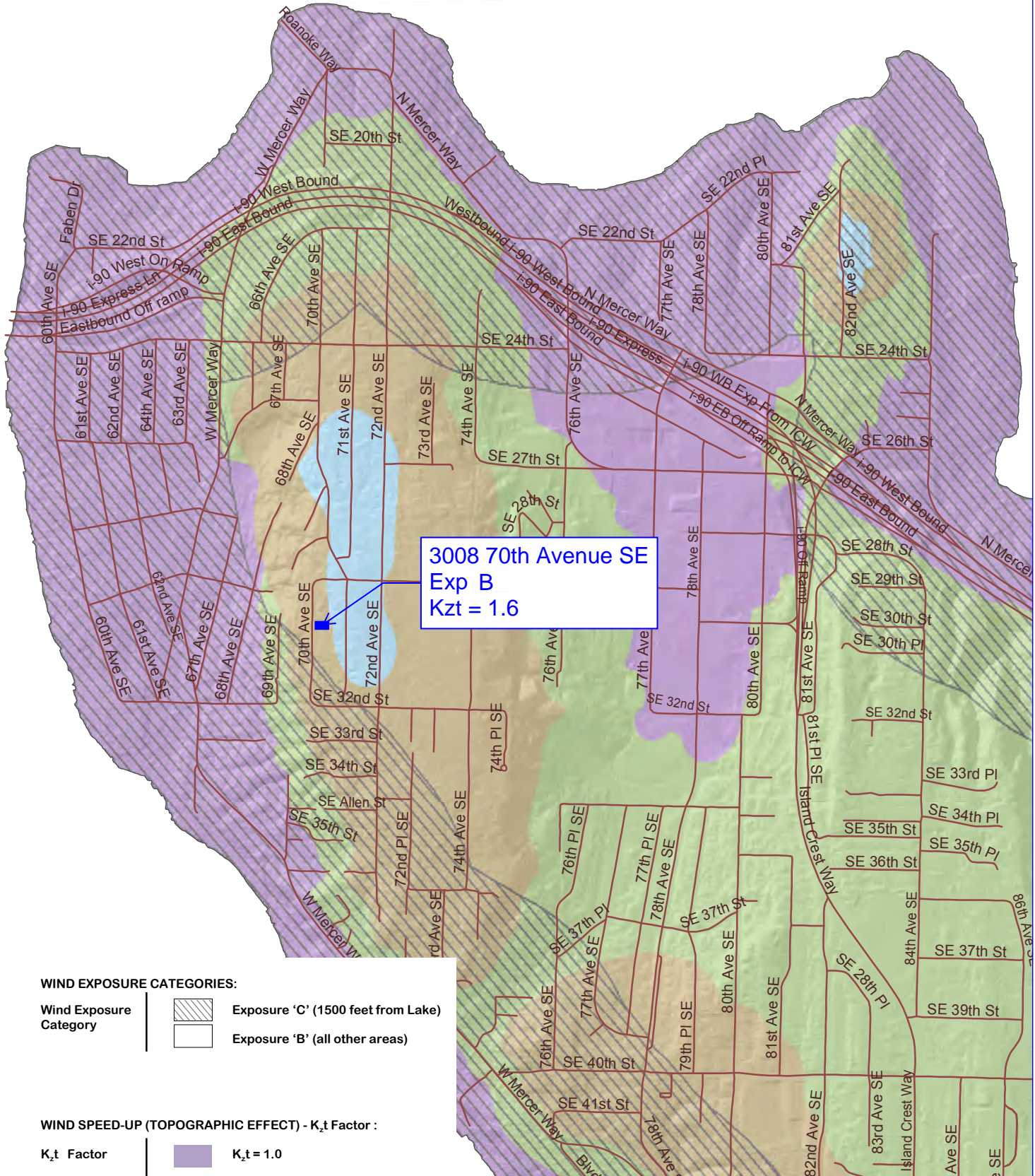

King County



WIND EXPOSURE CATEGORIES:

Wind Exposure Category		Exposure 'C' (1500 feet from Lake)
		Exposure 'B' (all other areas)

WIND SPEED-UP (TOPOGRAPHIC EFFECT) - $K_{z,t}$ Factor :

$K_{z,t}$ Factor		$K_{z,t} = 1.0$
		$K_{z,t} = 1.3$
		$K_{z,t} = 1.6$
		$K_{z,t} = 1.9$



3008 70th Ave SE, Mercer Island, WA 98040, USA

Latitude, Longitude: 47.5834996, -122.2449016



Date	3/25/2024, 10:58:34 AM
Design Code Reference Document	ASCE7-16
Risk Category	II
Site Class	D - Default (See Section 11.4.3)

Type	Value	Description
S _S	1.405	MCE _R ground motion. (for 0.2 second period)
S ₁	0.489	MCE _R ground motion. (for 1.0s period)
S _{MS}	1.685	Site-modified spectral acceleration value
S _{M1}	null -See Section 11.4.8	Site-modified spectral acceleration value
S _{DS}	1.124	Numeric seismic design value at 0.2 second SA
S _{D1}	null -See Section 11.4.8	Numeric seismic design value at 1.0 second SA

Type	Value	Description
SDC	null -See Section 11.4.8	Seismic design category
F _a	1.2	Site amplification factor at 0.2 second
F _v	null -See Section 11.4.8	Site amplification factor at 1.0 second
PGA	0.601	MCE _G peak ground acceleration
F _{PGA}	1.2	Site amplification factor at PGA
PGA _M	0.721	Site modified peak ground acceleration
T _L	6	Long-period transition period in seconds
SsRT	1.405	Probabilistic risk-targeted ground motion. (0.2 second)
SsUH	1.557	Factored uniform-hazard (2% probability of exceedance in 50 years) spectral acceleration
SsD	3.305	Factored deterministic acceleration value. (0.2 second)
S1RT	0.489	Probabilistic risk-targeted ground motion. (1.0 second)
S1UH	0.545	Factored uniform-hazard (2% probability of exceedance in 50 years) spectral acceleration.
S1D	1.342	Factored deterministic acceleration value. (1.0 second)
PGA _d	1.138	Factored deterministic acceleration value. (Peak Ground Acceleration)
PGA _{UH}	0.601	Uniform-hazard (2% probability of exceedance in 50 years) Peak Ground Acceleration
C _{RS}	0.902	Mapped value of the risk coefficient at short periods
C _{R1}	0.896	Mapped value of the risk coefficient at a period of 1 s
C _V	1.381	Vertical coefficient

BTL

ENGINEERING

19011 Wood-Sno Road NE, Suite 100

Woodinville, WA 98072-4436

Phone: (425) 814-8448

Fax: (425) 821-2120

Gravity
Roof Framing

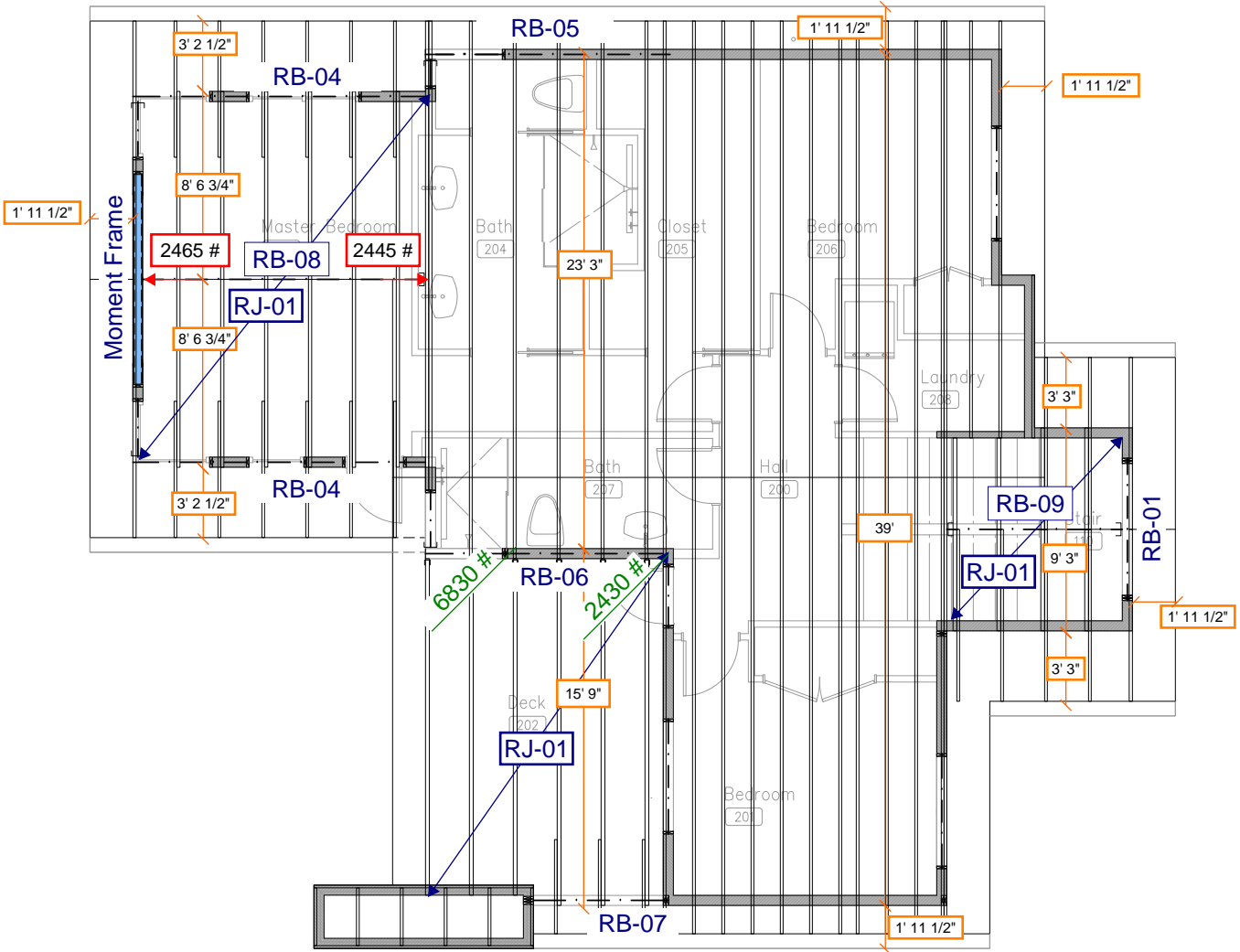

Roof Framing Key Plan

Roof, RJ-01

1 piece(s) 9 1/2" TJI® 210 @ 24" OC

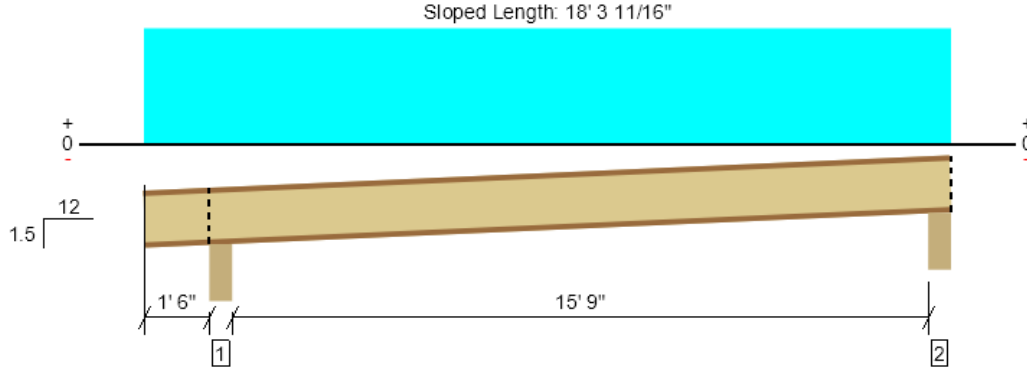

Drawing is Conceptual. All locations are measured from the outside face of left support (or left cantilever end). All dimensions are horizontal (typ.).

Design Results	Actual @ Location	Allowed	Result	LDF	Load: Combination (Pattern)
Member Reaction (lbs)	669 @ 17' 9 1/2"	1679 (3.50")	Passed (40%)	1.15	1.0 D + 1.0 S (Alt Spans)
Shear (lbs)	633 @ 17' 8 1/2"	1530	Passed (41%)	1.15	1.0 D + 1.0 S (Alt Spans)
Moment (Ft-lbs)	2546 @ 9' 9 7/8"	3450	Passed (74%)	1.15	1.0 D + 1.0 S (Alt Spans)
Live Load Defl. (in)	0.439 @ 9' 9 5/16"	0.809	Passed (L/442)	--	1.0 D + 1.0 S (Alt Spans)
Total Load Defl. (in)	0.702 @ 9' 9 3/8"	1.079	Passed (L/277)	--	1.0 D + 1.0 S (Alt Spans)

Member Length : 18' 4 7/8"
 System : Roof
 Member Type : Joist
 Building Use : Residential
 Building Code : IBC 2018
 Design Methodology : ASD
 Member Pitch : 1.5/12

- Deflection criteria: LL (L/240) and TL (L/180).
- Overhang deflection criteria: LL (2L/240) and TL (2L/180).
- Allowed moment does not reflect the adjustment for the beam stability factor.

Supports	Bearing Length			Loads to Supports (lbs)			Accessories
	Total	Available	Required	Dead	Snow	Total	
1 - Beveled Plate - HF	5.50"	5.50"	3.50"	298	493	791	Blocking
2 - Beveled Plate - HF	5.50"	5.50"	1.75"	251	418	669	Blocking

• Blocking Panels are assumed to carry no loads applied directly above them and the full load is applied to the member being designed.

Lateral Bracing	Bracing Intervals	Comments
Top Edge (Lu)	4' o/c	
Bottom Edge (Lu)	8' 8" o/c	

- TJI joists are only analyzed using Maximum Allowable bracing solutions.
- Maximum allowable bracing intervals based on applied load.
- Dimensions for lateral bracing intervals are measured along the length of the member for sloped conditions.

Vertical Load	Location	Spacing	Dead (0.90)	Snow (1.15)	Comments
1 - Uniform (PSF)	0 to 18' 2"	24"	15.0	25.0	Roof

Weyerhaeuser Notes
 Weyerhaeuser warrants that the sizing of its products will be in accordance with Weyerhaeuser product design criteria and published design values. Weyerhaeuser expressly disclaims any other warranties related to the software. Use of this software is not intended to circumvent the need for a design professional as determined by the authority having jurisdiction. The designer of record, builder or framer is responsible to assure that this calculation is compatible with the overall project. Accessories (Rim Board, Blocking Panels and Squash Blocks) are not designed by this software. Products manufactured at Weyerhaeuser facilities are third-party certified to sustainable forestry standards. Weyerhaeuser Engineered Lumber Products have been evaluated by ICC-ES under evaluation reports ESR-1153 and ESR-1387 and/or tested in accordance with applicable ASTM standards. For current code evaluation reports, Weyerhaeuser product literature and installation details refer to www.weyerhaeuser.com/woodproducts/document-library.
 The product application, input design loads, dimensions and support information have been provided by ForteWEB Software Operator

ForteWEB Software Operator	Job Notes
Mariam Soliman BTL Engineering PS (425) 814-8448 mariam.soliman@btleng.net	



9/20/2024 9:05:21 PM UTC
 ForteWEB v3.8, Engine: V8.4.1.24, Data: V8.1.6.3
 File Name: Dann Residence

Roof, RB-01

1 piece(s) 5 1/2" x 7 1/2" 24F-V4 DF Glulam

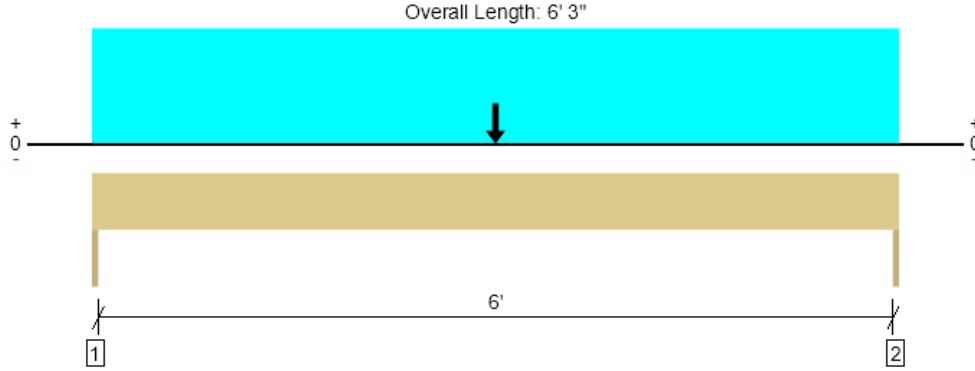

Drawing is Conceptual. All locations are measured from the outside face of left support (or left cantilever end). All dimensions are horizontal (typ.).

Design Results	Actual @ Location	Allowed	Result	LDF	Load: Combination (Pattern)
Member Reaction (lbs)	840 @ 0	5363 (1.50")	Passed (16%)	--	1.0 D + 1.0 S (All Spans)
Shear (lbs)	743 @ 9"	8381	Passed (9%)	1.15	1.0 D + 1.0 S (All Spans)
Pos Moment (Ft-lbs)	1991 @ 3' 1 1/2"	11859	Passed (17%)	1.15	1.0 D + 1.0 S (All Spans)
Live Load Defl. (in)	0.020 @ 3' 1 1/2"	0.208	Passed (L/999+)	--	1.0 D + 1.0 S (All Spans)
Total Load Defl. (in)	0.035 @ 3' 1 1/2"	0.313	Passed (L/999+)	--	1.0 D + 1.0 S (All Spans)

Member Length : 6' 3"
 System : Wall
 Member Type : Header
 Building Use : Residential
 Building Code : IBC 2018
 Design Methodology : ASD

- Deflection criteria: LL (L/360) and TL (L/240).
- Allowed moment does not reflect the adjustment for the beam stability factor.
- Critical positive moment adjusted by a volume/size factor of 1.00 that was calculated using length L = 6' 3".
- The effects of positive or negative camber have not been accounted for when calculating deflection.
- The specified glulam is assumed to have its strong laminations at the bottom of the beam. Install with proper side up as indicated by the manufacturer.
- Applicable calculations are based on NDS.

Supports	Bearing Length			Loads to Supports (lbs)			Accessories
	Total	Available	Required	Dead	Snow	Total	
1 - Trimmer - HF	1.50"	1.50"	1.50"	350	490	840	None
2 - Trimmer - HF	1.50"	1.50"	1.50"	350	490	840	None

Lateral Bracing	Bracing Intervals	Comments
Top Edge (Lu)	6' 3" o/c	
Bottom Edge (Lu)	6' 3" o/c	

•Maximum allowable bracing intervals based on applied load.

Vertical Loads	Location	Tributary Width	Dead (0.90)	Snow (1.15)	Comments
0 - Self Weight (PLF)	0 to 6' 3"	N/A	10.0	--	
1 - Uniform (PSF)	0 to 6' 3"	3'	15.0	25.0	Roof
2 - Point (lb)	3' 1 1/2"	N/A	357	511	Linked from: RB-09, Support 2

Weyerhaeuser Notes

Weyerhaeuser warrants that the sizing of its products will be in accordance with Weyerhaeuser product design criteria and published design values. Weyerhaeuser expressly disclaims any other warranties related to the software. Use of this software is not intended to circumvent the need for a design professional as determined by the authority having jurisdiction. The designer of record, builder or framer is responsible to assure that this calculation is compatible with the overall project. Accessories (Rim Board, Blocking Panels and Squash Blocks) are not designed by this software. Products manufactured at Weyerhaeuser facilities are third-party certified to sustainable forestry standards. Weyerhaeuser Engineered Lumber Products have been evaluated by ICC-ES under evaluation reports ESR-1153 and ESR-1387 and/or tested in accordance with applicable ASTM standards. For current code evaluation reports, Weyerhaeuser product literature and installation details refer to www.weyerhaeuser.com/woodproducts/document-library.

The product application, input design loads, dimensions and support information have been provided by ForteWEB Software Operator

ForteWEB Software Operator	Job Notes
Mariam Soliman BTL Engineering PS (425) 814-8448 mariam.soliman@bt leng.net	



9/28/2024 10:16:17 PM UTC
 ForteWEB v3.8, Engine: V8.4.1.24, Data: V8.1.6.3
 File Name: Dann Residence

Roof, RB-04

1 piece(s) 5 1/2" x 9" 24F-V4 DF Glulam

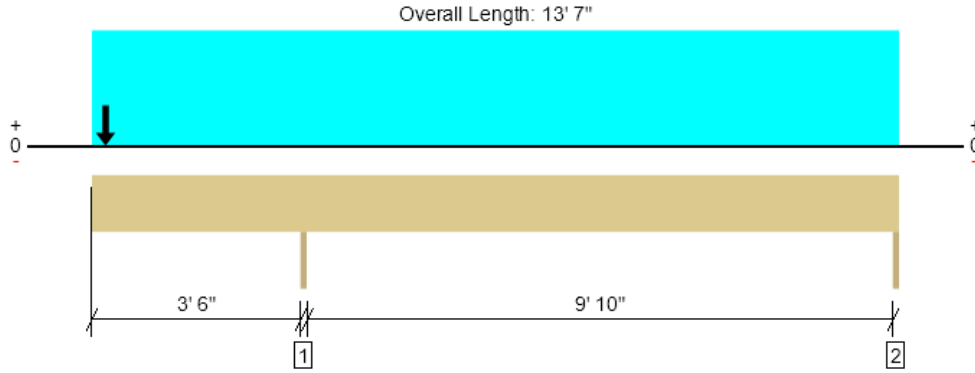

Drawing is Conceptual. All locations are measured from the outside face of left support (or left cantilever end). All dimensions are horizontal (typ.).

Design Results	Actual @ Location	Allowed	Result	LDF	Load: Combination (Pattern)
Member Reaction (lbs)	3146 @ 3' 6 3/4"	5363 (1.50")	Passed (59%)	--	1.0 D + 1.0 S (All Spans)
Shear (lbs)	1576 @ 4' 4 1/2"	10057	Passed (16%)	1.15	1.0 D + 1.0 S (All Spans)
Pos Moment (Ft-lbs)	3038 @ 9' 2 1/16"	17078	Passed (18%)	1.15	1.0 D + 1.0 S (Alt Spans)
Neg Moment (Ft-lbs)	-2663 @ 3' 6 3/4"	13164	Passed (20%)	1.15	1.0 D + 1.0 S (All Spans)
Live Load Defl. (in)	0.056 @ 8' 8 15/16"	0.334	Passed (L/999+)	--	1.0 D + 1.0 S (Alt Spans)
Total Load Defl. (in)	0.084 @ 8' 10"	0.501	Passed (L/999+)	--	1.0 D + 1.0 S (Alt Spans)

Member Length : 13' 7"
 System : Wall
 Member Type : Header
 Building Use : Residential
 Building Code : IBC 2018
 Design Methodology : ASD

- Deflection criteria: LL (L/360) and TL (L/240).
- Overhang deflection criteria: LL (2L/360) and TL (2L/240).
- Allowed moment does not reflect the adjustment for the beam stability factor.
- Critical positive moment adjusted by a volume/size factor of 1.00 that was calculated using length L = 8' 9 15/16".
- Critical negative moment adjusted by a volume/size factor of 1.00 that was calculated using length L = 5' 3 3/16".
- The effects of positive or negative camber have not been accounted for when calculating deflection.
- The specified glulam is assumed to have its strong laminations at the bottom of the beam. Install with proper side up as indicated by the manufacturer.
- Applicable calculations are based on NDS.

Supports	Bearing Length			Loads to Supports (lbs)			Accessories
	Total	Available	Required	Dead	Snow	Total	
1 - Trimmer - HF	1.50"	1.50"	1.50"	1260	1886	3146	None
2 - Trimmer - HF	1.50"	1.50"	1.50"	517	860	1377	None

Lateral Bracing	Bracing Intervals	Comments
Top Edge (Lu)	13' 7" o/c	
Bottom Edge (Lu)	13' 7" o/c	

•Maximum allowable bracing intervals based on applied load.

Vertical Loads	Location	Tributary Width	Dead (0.90)	Snow (1.15)	Comments
0 - Self Weight (PLF)	0 to 13' 7"	N/A	12.0	--	
1 - Uniform (PSF)	0 to 13' 7"	7' 6"	15.0	25.0	Roof
2 - Point (lb)	2-3/4"	N/A	85	120	Linked from: RB-03, Support 1

N/A

Weyerhaeuser Notes

Weyerhaeuser warrants that the sizing of its products will be in accordance with Weyerhaeuser product design criteria and published design values. Weyerhaeuser expressly disclaims any other warranties related to the software. Use of this software is not intended to circumvent the need for a design professional as determined by the authority having jurisdiction. The designer of record, builder or framer is responsible to assure that this calculation is compatible with the overall project. Accessories (Rim Board, Blocking Panels and Squash Blocks) are not designed by this software. Products manufactured at Weyerhaeuser facilities are third-party certified to sustainable forestry standards. Weyerhaeuser Engineered Lumber Products have been evaluated by ICC-ES under evaluation reports ESR-1153 and ESR-1387 and/or tested in accordance with applicable ASTM standards. For current code evaluation reports, Weyerhaeuser product literature and installation details refer to www.weyerhaeuser.com/woodproducts/document-library.

The product application, input design loads, dimensions and support information have been provided by ForteWEB Software Operator

ForteWEB Software Operator	Job Notes
Mariam Soliman BTL Engineering PS (425) 814-8448 mariam.soliman@btleng.net	



9/20/2024 9:05:21 PM UTC
 ForteWEB v3.8, Engine: V8.4.1.24, Data: V8.1.6.3
 File Name: Dann Residence

Roof, RB-05

1 piece(s) 5 1/2" x 7 1/2" 24F-V4 DF Glulam

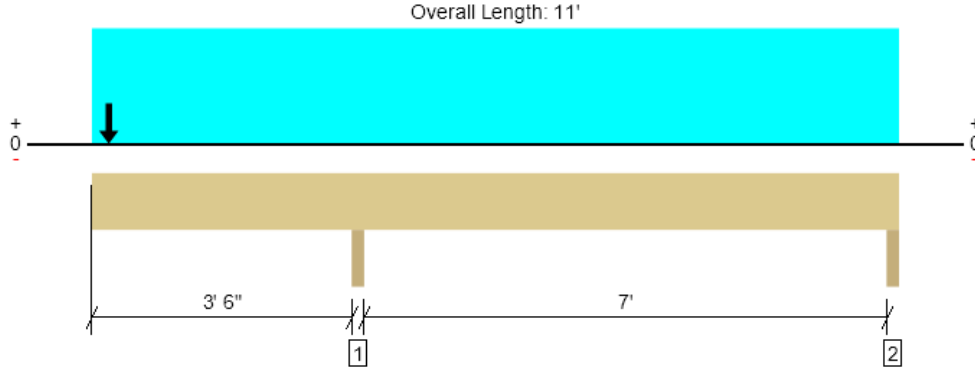

Drawing is Conceptual. All locations are measured from the outside face of left support (or left cantilever end). All dimensions are horizontal (typ.).

Design Results	Actual @ Location	Allowed	Result	LDF	Load: Combination (Pattern)
Member Reaction (lbs)	4175 @ 3' 7 1/2"	10725 (3.00")	Passed (39%)	--	1.0 D + 1.0 S (All Spans)
Shear (lbs)	1892 @ 4' 4 1/2"	8381	Passed (23%)	1.15	1.0 D + 1.0 S (All Spans)
Pos Moment (Ft-lbs)	1933 @ 8' 1/4"	11859	Passed (16%)	1.15	1.0 D + 1.0 S (Alt Spans)
Neg Moment (Ft-lbs)	-3817 @ 3' 7 1/2"	9142	Passed (42%)	1.15	1.0 D + 1.0 S (All Spans)
Live Load Defl. (in)	0.099 @ 0	0.242	Passed (2L/880)	--	1.0 D + 1.0 S (Alt Spans)
Total Load Defl. (in)	0.137 @ 0	0.363	Passed (2L/634)	--	1.0 D + 1.0 S (Alt Spans)

Member Length : 11'
 System : Wall
 Member Type : Header
 Building Use : Residential
 Building Code : IBC 2018
 Design Methodology : ASD

- Deflection criteria: LL (L/360) and TL (L/240).
- Overhang deflection criteria: LL (2L/360) and TL (2L/240).
- Allowed moment does not reflect the adjustment for the beam stability factor.
- Critical positive moment adjusted by a volume/size factor of 1.00 that was calculated using length L = 5' 8 1/2".
- Critical negative moment adjusted by a volume/size factor of 1.00 that was calculated using length L = 5' 10 1/8".
- The effects of positive or negative camber have not been accounted for when calculating deflection.
- The specified glulam is assumed to have its strong laminations at the bottom of the beam. Install with proper side up as indicated by the manufacturer.
- Applicable calculations are based on NDS.

Supports	Bearing Length			Loads to Supports (lbs)			Accessories
	Total	Available	Required	Dead	Snow	Total	
1 - Trimmer - HF	3.00"	3.00"	1.50"	1629	2547	4176	None
2 - Trimmer - HF	3.00"	3.00"	1.50"	485	930	1415	None

Lateral Bracing	Bracing Intervals	Comments
Top Edge (Lu)	11' o/c	
Bottom Edge (Lu)	11' o/c	

•Maximum allowable bracing intervals based on applied load.

Vertical Loads	Location	Tributary Width	Dead (0.90)	Snow (1.15)	Comments
0 - Self Weight (PLF)	0 to 11'	N/A	10.0	--	
1 - Uniform (PSF)	0 to 11'	11' 7 1/2"	15.0	25.0	Roof
2 - Point (lb)	2-3/4"	N/A	85	120	Linked from: RB-03, Support 1

N/A

Weyerhaeuser Notes

Weyerhaeuser warrants that the sizing of its products will be in accordance with Weyerhaeuser product design criteria and published design values. Weyerhaeuser expressly disclaims any other warranties related to the software. Use of this software is not intended to circumvent the need for a design professional as determined by the authority having jurisdiction. The designer of record, builder or framer is responsible to assure that this calculation is compatible with the overall project. Accessories (Rim Board, Blocking Panels and Squash Blocks) are not designed by this software. Products manufactured at Weyerhaeuser facilities are third-party certified to sustainable forestry standards. Weyerhaeuser Engineered Lumber Products have been evaluated by ICC-ES under evaluation reports ESR-1153 and ESR-1387 and/or tested in accordance with applicable ASTM standards. For current code evaluation reports, Weyerhaeuser product literature and installation details refer to www.weyerhaeuser.com/woodproducts/document-library.

The product application, input design loads, dimensions and support information have been provided by ForteWEB Software Operator

ForteWEB Software Operator	Job Notes
Mariam Soliman BTL Engineering PS (425) 814-8448 mariam.soliman@btleng.net	



9/20/2024 9:05:21 PM UTC
 ForteWEB v3.8, Engine: V8.4.1.24, Data: V8.1.6.3
 File Name: Dann Residence

Roof, RB-06

1 piece(s) 5 1/2" x 7 1/2" 24F-V4 DF Glulam

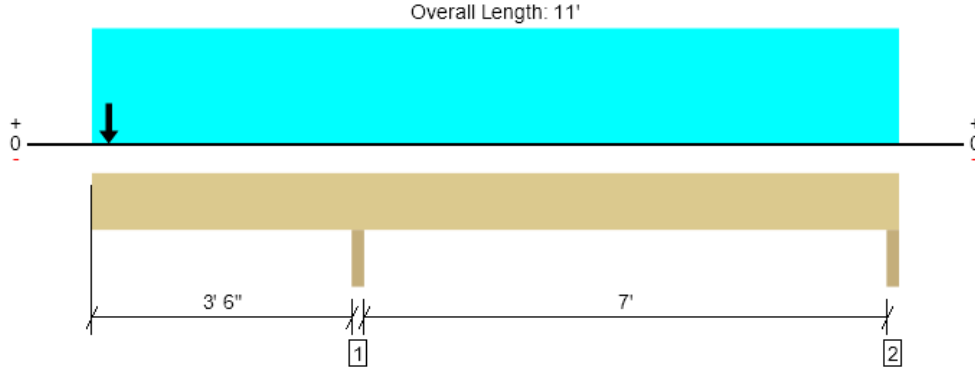

Drawing is Conceptual. All locations are measured from the outside face of left support (or left cantilever end). All dimensions are horizontal (typ.).

Design Results	Actual @ Location	Allowed	Result	LDF	Load: Combination (Pattern)
Member Reaction (lbs)	6826 @ 3' 7 1/2"	10725 (3.00")	Passed (64%)	--	1.0 D + 1.0 S (All Spans)
Shear (lbs)	3121 @ 4' 4 1/2"	8381	Passed (37%)	1.15	1.0 D + 1.0 S (All Spans)
Pos Moment (Ft-lbs)	3396 @ 7' 11 9/16"	11859	Passed (29%)	1.15	1.0 D + 1.0 S (Alt Spans)
Neg Moment (Ft-lbs)	-5953 @ 3' 7 1/2"	9142	Passed (65%)	1.15	1.0 D + 1.0 S (All Spans)
Live Load Defl. (in)	0.150 @ 0	0.242	Passed (2L/580)	--	1.0 D + 1.0 S (Alt Spans)
Total Load Defl. (in)	0.201 @ 0	0.363	Passed (2L/432)	--	1.0 D + 1.0 S (Alt Spans)

Member Length : 11'
 System : Wall
 Member Type : Header
 Building Use : Residential
 Building Code : IBC 2018
 Design Methodology : ASD

- Deflection criteria: LL (L/360) and TL (L/240).
- Overhang deflection criteria: LL (2L/360) and TL (2L/240).
- Allowed moment does not reflect the adjustment for the beam stability factor.
- Critical positive moment adjusted by a volume/size factor of 1.00 that was calculated using length L = 5' 9 15/16".
- Critical negative moment adjusted by a volume/size factor of 1.00 that was calculated using length L = 5' 8 1/8".
- The effects of positive or negative camber have not been accounted for when calculating deflection.
- The specified glulam is assumed to have its strong laminations at the bottom of the beam. Install with proper side up as indicated by the manufacturer.
- Applicable calculations are based on NDS.

Supports	Bearing Length			Loads to Supports (lbs)			Accessories
	Total	Available	Required	Dead	Snow	Total	
1 - Trimmer - HF	3.00"	3.00"	1.91"	2623	4203	6826	None
2 - Trimmer - HF	3.00"	3.00"	1.50"	831	1600	2431	None

Lateral Bracing	Bracing Intervals	Comments
Top Edge (Lu)	11' o/c	
Bottom Edge (Lu)	11' o/c	

•Maximum allowable bracing intervals based on applied load.

Vertical Loads	Location	Tributary Width	Dead (0.90)	Snow (1.15)	Comments
0 - Self Weight (PLF)	0 to 11'	N/A	10.0	--	
1 - Uniform (PSF)	0 to 11'	19' 9"	15.0	25.0	Roof
2 - Point (lb)	2-3/4"	N/A	85	120	Linked from: RB-03, Support 1

N/A

Weyerhaeuser Notes

Weyerhaeuser warrants that the sizing of its products will be in accordance with Weyerhaeuser product design criteria and published design values. Weyerhaeuser expressly disclaims any other warranties related to the software. Use of this software is not intended to circumvent the need for a design professional as determined by the authority having jurisdiction. The designer of record, builder or framer is responsible to assure that this calculation is compatible with the overall project. Accessories (Rim Board, Blocking Panels and Squash Blocks) are not designed by this software. Products manufactured at Weyerhaeuser facilities are third-party certified to sustainable forestry standards. Weyerhaeuser Engineered Lumber Products have been evaluated by ICC-ES under evaluation reports ESR-1153 and ESR-1387 and/or tested in accordance with applicable ASTM standards. For current code evaluation reports, Weyerhaeuser product literature and installation details refer to www.weyerhaeuser.com/woodproducts/document-library.

The product application, input design loads, dimensions and support information have been provided by ForteWEB Software Operator

ForteWEB Software Operator	Job Notes
Mariam Soliman BTL Engineering PS (425) 814-8448 mariam.soliman@btleng.net	



9/20/2024 9:05:21 PM UTC
 ForteWEB v3.8, Engine: V8.4.1.24, Data: V8.1.6.3
 File Name: Dann Residence

Roof, RB-07

1 piece(s) 5 1/2" x 7 1/2" 24F-V4 DF Glulam

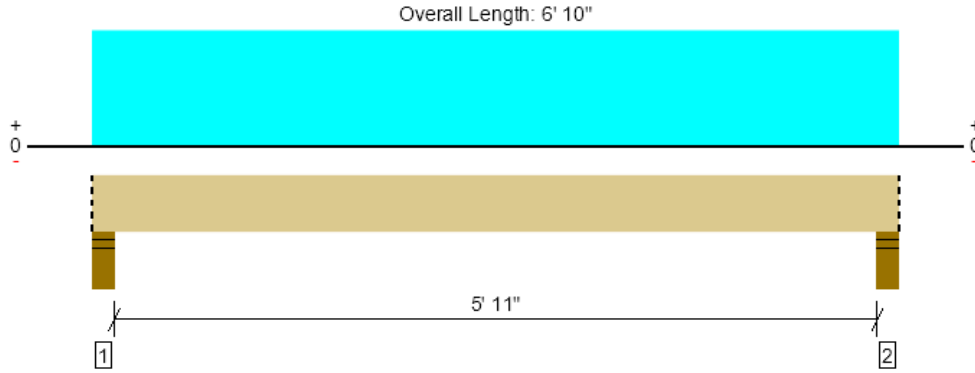

Drawing is Conceptual. All locations are measured from the outside face of left support (or left cantilever end). All dimensions are horizontal (typ.).

Design Results	Actual @ Location	Allowed	Result	LDF	Load: Combination (Pattern)
Member Reaction (lbs)	1314 @ 4"	12251 (5.50")	Passed (11%)	--	1.0 D + 1.0 S (All Spans)
Shear (lbs)	898 @ 1' 1"	8381	Passed (11%)	1.15	1.0 D + 1.0 S (All Spans)
Pos Moment (Ft-lbs)	1828 @ 3' 5"	11859	Passed (15%)	1.15	1.0 D + 1.0 S (All Spans)
Live Load Defl. (in)	0.024 @ 3' 5"	0.308	Passed (L/999+)	--	1.0 D + 1.0 S (All Spans)
Total Load Defl. (in)	0.036 @ 3' 5"	0.411	Passed (L/999+)	--	1.0 D + 1.0 S (All Spans)

Member Length : 6' 10"
 System : Roof
 Member Type : Flush Beam
 Building Use : Residential
 Building Code : IBC 2018
 Design Methodology : ASD
 Member Pitch : 0/12

- Deflection criteria: LL (L/240) and TL (L/180).
- Allowed moment does not reflect the adjustment for the beam stability factor.
- Critical positive moment adjusted by a volume/size factor of 1.00 that was calculated using length L = 6' 2".
- The effects of positive or negative camber have not been accounted for when calculating deflection.
- The specified glulam is assumed to have its strong laminations at the bottom of the beam. Install with proper side up as indicated by the manufacturer.
- Applicable calculations are based on NDS.

Supports	Bearing Length			Loads to Supports (lbs)			Accessories
	Total	Available	Required	Dead	Snow	Total	
1 - Stud wall - HF	5.50"	5.50"	1.50"	449	865	1314	Blocking
2 - Stud wall - HF	5.50"	5.50"	1.50"	449	865	1314	Blocking

- Blocking Panels are assumed to carry no loads applied directly above them and the full load is applied to the member being designed.

Lateral Bracing	Bracing Intervals	Comments
Top Edge (Lu)	6' 10" o/c	
Bottom Edge (Lu)	6' 10" o/c	

- Maximum allowable bracing intervals based on applied load.

Vertical Loads	Location (Side)	Tributary Width	Dead (0.90)	Snow (1.15)	Comments
0 - Self Weight (PLF)	0 to 6' 10"	N/A	10.0	--	
1 - Uniform (PSF)	0 to 6' 10" (Front)	10' 1 1/2"	12.0	25.0	Roof

- Side loads are assumed to not induce cross-grain tension.

Weyerhaeuser Notes

Weyerhaeuser warrants that the sizing of its products will be in accordance with Weyerhaeuser product design criteria and published design values. Weyerhaeuser expressly disclaims any other warranties related to the software. Use of this software is not intended to circumvent the need for a design professional as determined by the authority having jurisdiction. The designer of record, builder or framer is responsible to assure that this calculation is compatible with the overall project. Accessories (Rim Board, Blocking Panels and Squash Blocks) are not designed by this software. Products manufactured at Weyerhaeuser facilities are third-party certified to sustainable forestry standards. Weyerhaeuser Engineered Lumber Products have been evaluated by ICC-ES under evaluation reports ESR-1153 and ESR-1387 and/or tested in accordance with applicable ASTM standards. For current code evaluation reports, Weyerhaeuser product literature and installation details refer to www.weyerhaeuser.com/woodproducts/document-library.

The product application, input design loads, dimensions and support information have been provided by ForteWEB Software Operator

ForteWEB Software Operator	Job Notes
Mariam Soliman BTL Engineering PS (425) 814-8448 mariam.soliman@btleng.net	



9/20/2024 9:05:21 PM UTC
 ForteWEB v3.8, Engine: V8.4.1.24, Data: V8.1.6.3
 File Name: Dann Residence

Roof, RB-08

1 piece(s) 5 1/2" x 12" 24F-V4 DF Glulam

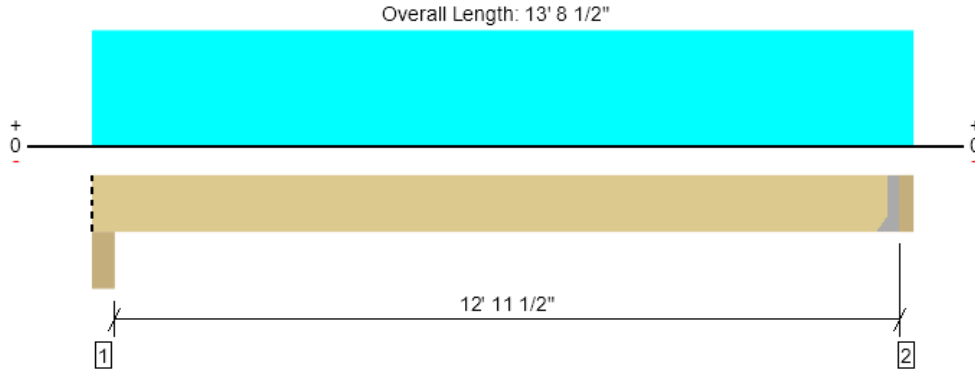

Drawing is Conceptual. All locations are measured from the outside face of left support (or left cantilever end). All dimensions are horizontal (typ.).

Design Results	Actual @ Location	Allowed	Result	LDF	Load: Combination (Pattern)
Member Reaction (lbs)	2345 @ 13' 5"	5363 (1.50")	Passed (44%)	--	1.0 D + 1.0 S (All Spans)
Shear (lbs)	1987 @ 12' 5"	13409	Passed (15%)	1.15	1.0 D + 1.0 S (All Spans)
Pos Moment (Ft-lbs)	7672 @ 6' 10 1/2"	30360	Passed (25%)	1.15	1.0 D + 1.0 S (All Spans)
Live Load Defl. (in)	0.099 @ 6' 10 1/2"	0.654	Passed (L/999+)	--	1.0 D + 1.0 S (All Spans)
Total Load Defl. (in)	0.166 @ 6' 10 1/2"	0.872	Passed (L/947)	--	1.0 D + 1.0 S (All Spans)

Member Length : 13' 5"
 System : Roof
 Member Type : Drop Beam
 Building Use : Residential
 Building Code : IBC 2018
 Design Methodology : ASD
 Member Pitch : 0/12

- Deflection criteria: LL (L/240) and TL (L/180).
- Allowed moment does not reflect the adjustment for the beam stability factor.
- Critical positive moment adjusted by a volume/size factor of 1.00 that was calculated using length L = 13' 1".
- The effects of positive or negative camber have not been accounted for when calculating deflection.
- The specified glulam is assumed to have its strong laminations at the bottom of the beam. Install with proper side up as indicated by the manufacturer.
- Applicable calculations are based on NDS.

Supports	Bearing Length			Loads to Supports (lbs)			Accessories
	Total	Available	Required	Dead	Snow	Total	
1 - Beam - GLB	5.50"	5.50"	1.50"	993	1472	2465	Blocking
2 - Hanger on 12" HF beam	3.50"	Hanger ¹	1.50"	983	1463	2446	See note ¹

- Blocking Panels are assumed to carry no loads applied directly above them and the full load is applied to the member being designed.
- At hanger supports, the Total Bearing dimension is equal to the width of the material that is supporting the hanger
- ¹ See Connector grid below for additional information and/or requirements.

Lateral Bracing	Bracing Intervals	Comments
Top Edge (Lu)	13' 5" o/c	
Bottom Edge (Lu)	13' 5" o/c	

•Maximum allowable bracing intervals based on applied load.

Connector: Simpson Strong-Tie						
Support	Model	Seat Length	Top Fasteners	Face Fasteners	Member Fasteners	Accessories
2 - Face Mount Hanger	HU610	2.50"	N/A	18-16d	8-16d	

- Refer to manufacturer notes and instructions for proper installation and use of all connectors.

Vertical Loads	Location (Side)	Tributary Width	Dead (0.90)	Snow (1.15)	Comments
0 - Self Weight (PLF)	0 to 13' 5"	N/A	16.0	--	
1 - Uniform (PSF)	0 to 13' 8 1/2" (Front)	8' 6 3/4"	15.0	25.0	Roof

• Side loads are assumed to not induce cross-grain tension.

ForteWEB Software Operator	Job Notes
Mariam Soliman BTL Engineering PS (425) 814-8448 mariam.soliman@btleng.net	



9/20/2024 9:52:50 PM UTC
 ForteWEB v3.8, Engine: V8.4.1.24, Data: V8.1.6.3
 File Name: Dann Residence

Roof, RB-09

1 piece(s) 5 1/2" x 9 1/2" 24F-V4 DF Glulam

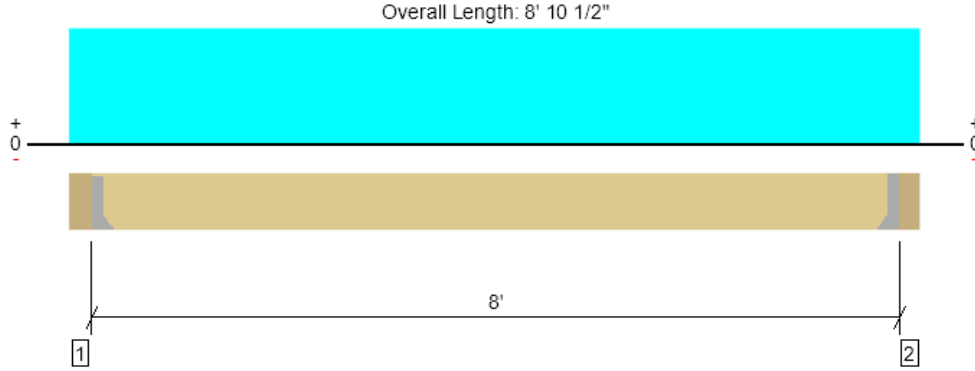

Drawing is Conceptual. All locations are measured from the outside face of left support (or left cantilever end). All dimensions are horizontal (typ.).

Design Results	Actual @ Location	Allowed	Result	LDF	Load: Combination (Pattern)
Member Reaction (lbs)	791 @ 5 1/2"	5363 (1.50")	Passed (15%)	--	1.0 D + 1.0 S (All Spans)
Shear (lbs)	634 @ 1' 3"	10615	Passed (6%)	1.15	1.0 D + 1.0 S (All Spans)
Pos Moment (Ft-lbs)	1582 @ 4' 5 1/2"	19028	Passed (8%)	1.15	1.0 D + 1.0 S (All Spans)
Live Load Defl. (in)	0.015 @ 4' 5 1/2"	0.400	Passed (L/999+)	--	1.0 D + 1.0 S (All Spans)
Total Load Defl. (in)	0.026 @ 4' 5 1/2"	0.533	Passed (L/999+)	--	1.0 D + 1.0 S (All Spans)

Member Length : 8'
 System : Roof
 Member Type : Drop Beam
 Building Use : Residential
 Building Code : IBC 2018
 Design Methodology : ASD
 Member Pitch : 0/12

- Deflection criteria: LL (L/240) and TL (L/180).
- Allowed moment does not reflect the adjustment for the beam stability factor.
- Critical positive moment adjusted by a volume/size factor of 1.00 that was calculated using length L = 8'.
- The effects of positive or negative camber have not been accounted for when calculating deflection.
- The specified glulam is assumed to have its strong laminations at the bottom of the beam. Install with proper side up as indicated by the manufacturer.
- Applicable calculations are based on NDS.

Supports	Bearing Length			Loads to Supports (lbs)			Accessories
	Total	Available	Required	Dead	Snow	Total	
1 - Hanger on 9 1/2" GLB beam	5.50"	Hanger ¹	1.50"	360	515	875	See note ¹
2 - Hanger on 9 1/2" GLB beam	5.00"	Hanger ¹	1.50"	357	511	868	See note ¹

- At hanger supports, the Total Bearing dimension is equal to the width of the material that is supporting the hanger
- ¹ See Connector grid below for additional information and/or requirements.

Lateral Bracing	Bracing Intervals	Comments
Top Edge (Lu)	8' o/c	
Bottom Edge (Lu)	8' o/c	

•Maximum allowable bracing intervals based on applied load.

Connector: Simpson Strong-Tie							
Support	Model	Seat Length	Top Fasteners	Face Fasteners	Member Fasteners	Accessories	
1 - Face Mount Hanger	HU610	2.50"	N/A	14-10dx1.5	6-10d		
2 - Face Mount Hanger	HU610	2.50"	N/A	14-10dx1.5	6-10d		

- Refer to manufacturer notes and instructions for proper installation and use of all connectors.

Vertical Loads	Location (Side)	Tributary Width	Dead (0.90)	Snow (1.15)	Comments
0 - Self Weight (PLF)	5 1/2" to 8' 5 1/2"	N/A	12.7	--	
1 - Uniform (PSF)	0 to 8' 10 1/2" (Front)	4' 7 1/2"	15.0	25.0	Roof

- Side loads are assumed to not induce cross-grain tension.

Forteweb Software Operator	Job Notes
Mariam Soliman BTL Engineering PS (425) 814-8448 mariam.soliman@btleng.net	



9/20/2024 9:52:50 PM UTC
 Forteweb v3.8, Engine: V8.4.1.24, Data: V8.1.6.3
 File Name: Dann Residence

BTL

ENGINEERING

19011 Wood-Sno Road NE, Suite 100

Woodinville, WA 98072-4436

Phone: (425) 814-8448

Fax: (425) 821-2120

Gravity
Upper Floor Framing

Upper Floor/ Main Wall, UJ-01

1 piece(s) 3 1/2" x 9 1/2" 2.2E Parallam® PSL @ 16" OC

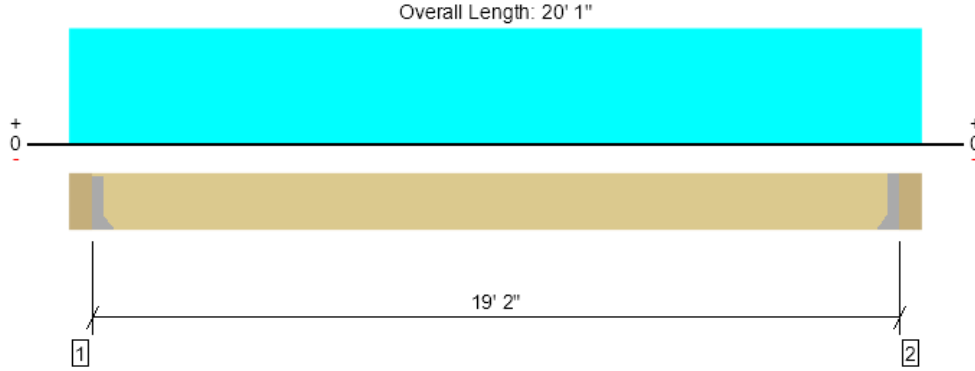

Drawing is Conceptual. All locations are measured from the outside face of left support (or left cantilever end). All dimensions are horizontal (typ.).

Design Results	Actual @ Location	Allowed	Result	LDF	Load: Combination (Pattern)
Member Reaction (lbs)	1086 @ 5 1/2"	3281 (1.50")	Passed (33%)	--	1.0 D + 1.0 L (All Spans)
Shear (lbs)	996 @ 1' 3"	6428	Passed (15%)	1.00	1.0 D + 1.0 L (All Spans)
Moment (Ft-lbs)	5204 @ 10' 1/2"	13579	Passed (38%)	1.00	1.0 D + 1.0 L (All Spans)
Live Load Defl. (in)	0.406 @ 10' 1/2"	0.479	Passed (L/566)	--	1.0 D + 1.0 L (All Spans)
Total Load Defl. (in)	0.576 @ 10' 1/2"	0.958	Passed (L/400)	--	1.0 D + 1.0 L (All Spans)
TJ-Pro™ Rating	51	40	Passed	--	--

Member Length : 19' 2"
 System : Floor
 Member Type : Joist
 Building Use : Residential
 Building Code : IBC 2018
 Design Methodology : ASD

- Deflection criteria: LL (L/480) and TL (L/240).
- Allowed moment does not reflect the adjustment for the beam stability factor.
- A 4% increase in the moment capacity has been added to account for repetitive member usage.
- A structural analysis of the deck has not been performed.
- Deflection analysis is based on composite action with a single layer of 23/32" Weyerhaeuser Edge™ Panel (24" Span Rating) that is glued and nailed down.
- Additional considerations for the TJ-Pro™ Rating include: 5/8" Gypsum ceiling.

Supports	Bearing Length			Loads to Supports (lbs)			Accessories
	Total	Available	Required	Dead	Floor Live	Factored	
1 - Hanger on 9 1/2" GLB beam	5.50"	Hanger ¹	1.50"	335	803	1138	See note ¹
2 - Hanger on 9 1/2" GLB beam	5.50"	Hanger ¹	1.50"	335	803	1138	See note ¹

- At hanger supports, the Total Bearing dimension is equal to the width of the material that is supporting the hanger
- ¹ See Connector grid below for additional information and/or requirements.

Lateral Bracing	Bracing Intervals	Comments
Top Edge (Lu)	19' 2" o/c	
Bottom Edge (Lu)	19' 2" o/c	

•Maximum allowable bracing intervals based on applied load.

Connector: Simpson Strong-Tie							
Support	Model	Seat Length	Top Fasteners	Face Fasteners	Member Fasteners	Accessories	
1 - Face Mount Hanger	LUS410	2.00"	N/A	8-10dx1.5	6-10d		
2 - Face Mount Hanger	LUS410	2.00"	N/A	8-10dx1.5	6-10d		

- Refer to manufacturer notes and instructions for proper installation and use of all connectors.

Vertical Load	Location (Side)	Spacing	Dead (0.90)	Floor Live (1.00)	Comments
1 - Uniform (PSF)	0 to 20' 1"	16"	25.0	60.0	Deck

Member Notes
(converted from: Roof Joist)

ForteWEB Software Operator	Job Notes
Mariam Soliman BTL Engineering PS (425) 814-8448 mariam.soliman@btleng.net	



9/29/2024 5:41:52 PM UTC
 ForteWEB v3.8, Engine: V8.4.1.24, Data: V8.1.6.3
 File Name: Dann Residence

Upper Floor/ Main Wall, UJ-02
1 piece(s) 11 7/8" TJI@ 210 @ 16" OC

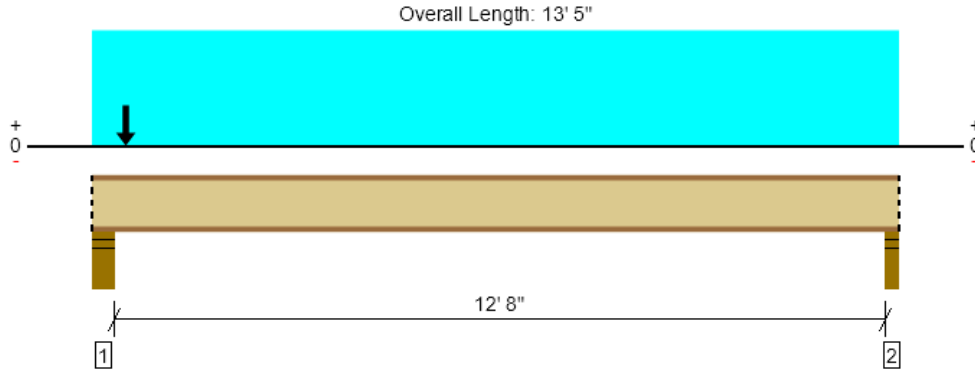

Drawing is Conceptual. All locations are measured from the outside face of left support (or left cantilever end). All dimensions are horizontal (typ.).

Design Results	Actual @ Location	Allowed	Result	LDF	Load: Combination (Pattern)
Member Reaction (lbs)	1369 @ 4 1/2"	1679 (3.50")	Passed (82%)	1.15	1.0 D + 0.75 L + 0.75 S (All Spans)
Shear (lbs)	1341 @ 5 1/2"	1903	Passed (70%)	1.15	1.0 D + 0.75 L + 0.75 S (All Spans)
Moment (Ft-lbs)	1551 @ 6' 8 7/16"	3795	Passed (41%)	1.00	1.0 D + 1.0 L (All Spans)
Live Load Defl. (in)	0.104 @ 6' 9 1/2"	0.321	Passed (L/999+)	--	1.0 D + 1.0 L (All Spans)
Total Load Defl. (in)	0.147 @ 6' 9 3/16"	0.642	Passed (L/999+)	--	1.0 D + 1.0 L (All Spans)
TJ-Pro™ Rating	59	40	Passed	--	--

Member Length : 13' 5"
 System : Floor
 Member Type : Joist
 Building Use : Residential
 Building Code : IBC 2018
 Design Methodology : ASD

- Deflection criteria: LL (L/480) and TL (L/240).
- Allowed moment does not reflect the adjustment for the beam stability factor.
- A structural analysis of the deck has not been performed.
- Deflection analysis is based on composite action with a single layer of 23/32" Weyerhaeuser Edge™ Panel (24" Span Rating) that is glued and nailed down.
- Additional considerations for the TJ-Pro™ Rating include: 5/8" Gypsum ceiling.

Supports	Bearing Length			Loads to Supports (lbs)				Accessories
	Total	Available	Required	Dead	Floor Live	Snow	Factored	
1 - Stud wall - HF	5.50"	5.50"	2.47"	567	362	707	1369	Blocking
2 - Stud wall - HF	3.50"	3.50"	1.75"	139	353	10	492	Blocking

• Blocking Panels are assumed to carry no loads applied directly above them and the full load is applied to the member being designed.

Lateral Bracing	Bracing Intervals	Comments
Top Edge (Lu)	5' 11" o/c	
Bottom Edge (Lu)	13' 5" o/c	

- TJI joists are only analyzed using Maximum Allowable bracing solutions.
- Maximum allowable bracing intervals based on applied load.

Vertical Loads	Location	Spacing	Dead (0.90)	Floor Live (1.00)	Snow (1.15)	Comments
1 - Uniform (PSF)	0 to 13' 5"	16"	15.0	40.0	-	Upper floor
2 - Point (PLF)	6 3/4"	16"	233.0	-	538.0	Roof DL=15psf x21.5'=323plf LL=25psf x21.5'=538plf
3 - Point (PLF)	6 3/4"	16"	95.0	-	-	Wall DL=10psf x9.5'=95plf

Member Notes
(converted from: Roof Joist)

ForteWEB Software Operator	Job Notes
Mariam Soliman BTL Engineering PS (425) 814-8448 mariam.soliman@btleng.net	



9/29/2024 5:41:52 PM UTC
 ForteWEB v3.8, Engine: V8.4.1.24, Data: V8.1.6.3
 File Name: Dann Residence

Upper Floor/ Main Wall, UJ-03
1 piece(s) 11 7/8" TJI@ 210 @ 16" OC

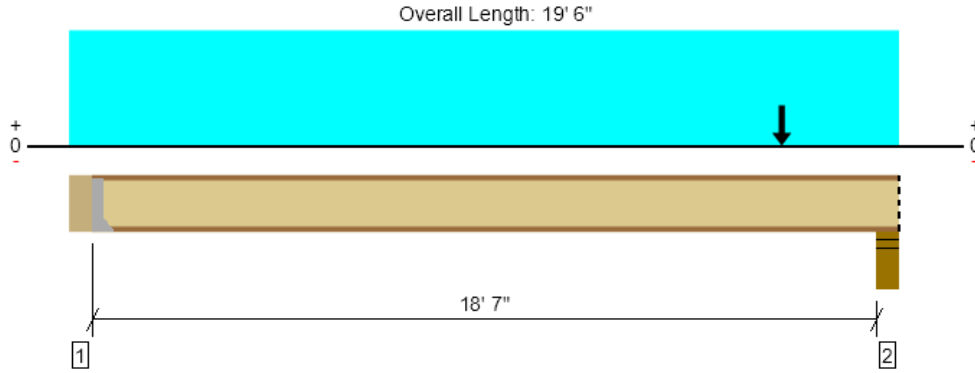

Drawing is Conceptual. All locations are measured from the outside face of left support (or left cantilever end). All dimensions are horizontal (typ.).

Design Results	Actual @ Location	Allowed	Result	LDF	Load: Combination (Pattern)
Member Reaction (lbs)	722 @ 5 1/2"	1005 (1.75")	Passed (72%)	1.00	1.0 D + 1.0 L (All Spans)
Shear (lbs)	924 @ 19' 1/2"	1655	Passed (56%)	1.00	1.0 D + 1.0 L (All Spans)
Moment (Ft-lbs)	3551 @ 10' 3 9/16"	3795	Passed (94%)	1.00	1.0 D + 1.0 L (All Spans)
Live Load Defl. (in)	0.418 @ 9' 9 1/2"	0.467	Passed (L/536)	--	1.0 D + 1.0 L (All Spans)
Total Load Defl. (in)	0.647 @ 9' 11 3/16"	0.933	Passed (L/346)	--	1.0 D + 1.0 L (All Spans)
TJ-Pro™ Rating	40	40	Passed	--	--

Member Length : 19' 1/2"
 System : Floor
 Member Type : Joist
 Building Use : Residential
 Building Code : IBC 2018
 Design Methodology : ASD

- Deflection criteria: LL (L/480) and TL (L/240).
- Allowed moment does not reflect the adjustment for the beam stability factor.
- A structural analysis of the deck has not been performed.
- Deflection analysis is based on composite action with a single layer of 23/32" Weyerhaeuser Edge™ Panel (24" Span Rating) that is glued and nailed down.
- Additional considerations for the TJ-Pro™ Rating include: 5/8" Gypsum ceiling.

Supports	Bearing Length			Loads to Supports (lbs)				Accessories
	Total	Available	Required	Dead	Floor Live	Snow	Factored	
1 - Hanger on 11 7/8" GLB beam	5.50"	Hanger ¹	1.75" / - ²	233	522	34	755	See note ¹
2 - Stud wall - HF	5.50"	5.50"	1.75"	440	518	226	997	Blocking

- Blocking Panels are assumed to carry no loads applied directly above them and the full load is applied to the member being designed.
- At hanger supports, the Total Bearing dimension is equal to the width of the material that is supporting the hanger
- ¹ See Connector grid below for additional information and/or requirements.
- ² Required Bearing Length / Required Bearing Length with Web Stiffeners

Lateral Bracing	Bracing Intervals	Comments
Top Edge (Lu)	3' 9" o/c	
Bottom Edge (Lu)	19' 1" o/c	

- TJI joists are only analyzed using Maximum Allowable bracing solutions.
- Maximum allowable bracing intervals based on applied load.

Connector: Simpson Strong-Tie

Support	Model	Seat Length	Top Fasteners	Face Fasteners	Member Fasteners	Accessories
1 - Face Mount Hanger	IUS2.06/11.88	2.00"	N/A	10-10dx1.5	2-Strong-Grip	

- Refer to manufacturer notes and instructions for proper installation and use of all connectors.

Vertical Loads	Location	Spacing	Dead (0.90)	Floor Live (1.00)	Snow (1.15)	Comments
1 - Uniform (PSF)	0 to 19' 6"	16"	15.0	40.0	-	Upper floor
2 - Point (PLF)	16' 8"	16"	117.0	-	195.0	Roof DL=15psf x7.8'=117 LL=25psf x7.8'=195plf
3 - Point (PLF)	16' 8"	16"	95.0	-	-	Wall DL=10psf x9.5'=95plf

ForteWEB Software Operator	Job Notes
Mariam Soliman BTL Engineering PS (425) 814-8448 mariam.soliman@btleng.net	



9/29/2024 5:41:52 PM UTC
 ForteWEB v3.8, Engine: V8.4.1.24, Data: V8.1.6.3
 File Name: Dann Residence

Upper Floor/ Main Wall, UJ-04
1 piece(s) 11 7/8" TJI® 210 @ 16" OC

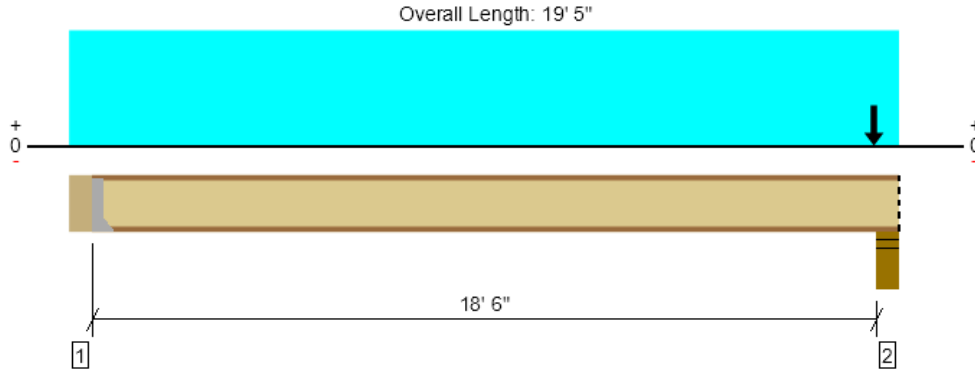

Drawing is Conceptual. All locations are measured from the outside face of left support (or left cantilever end). All dimensions are horizontal (typ.).

Design Results	Actual @ Location	Allowed	Result	LDF	Load: Combination (Pattern)
Member Reaction (lbs)	1662 @ 19' 1/2"	1679 (3.50")	Passed (99%)	1.15	1.0 D + 0.75 L + 0.75 S (All Spans)
Shear (lbs)	1634 @ 18' 11 1/2"	1903	Passed (86%)	1.15	1.0 D + 0.75 L + 0.75 S (All Spans)
Moment (Ft-lbs)	3230 @ 9' 10 1/8"	3795	Passed (85%)	1.00	1.0 D + 1.0 L (All Spans)
Live Load Defl. (in)	0.411 @ 9' 9"	0.465	Passed (L/543)	--	1.0 D + 1.0 L (All Spans)
Total Load Defl. (in)	0.579 @ 9' 9 3/8"	0.929	Passed (L/385)	--	1.0 D + 1.0 L (All Spans)
TJ-Pro™ Rating	40	40	Passed	--	--

Member Length : 18' 11 1/2"
 System : Floor
 Member Type : Joist
 Building Use : Residential
 Building Code : IBC 2018
 Design Methodology : ASD

- Deflection criteria: LL (L/480) and TL (L/240).
- Allowed moment does not reflect the adjustment for the beam stability factor.
- A structural analysis of the deck has not been performed.
- Deflection analysis is based on composite action with a single layer of 23/32" Weyerhaeuser Edge™ Panel (24" Span Rating) that is glued and nailed down.
- Additional considerations for the TJ-Pro™ Rating include: 5/8" Gypsum ceiling.

Supports	Bearing Length			Loads to Supports (lbs)				Accessories
	Total	Available	Required	Dead	Floor Live	Snow	Factored	
1 - Hanger on 11 7/8" GLB beam	5.50"	Hanger ¹	1.75" / - ²	202	520	9	722	See note ¹
2 - Stud wall - HF	5.50"	5.50"	3.44"	744	516	708	1662	Blocking

- Blocking Panels are assumed to carry no loads applied directly above them and the full load is applied to the member being designed.
- At hanger supports, the Total Bearing dimension is equal to the width of the material that is supporting the hanger
- ¹ See Connector grid below for additional information and/or requirements.
- ² Required Bearing Length / Required Bearing Length with Web Stiffeners

Lateral Bracing	Bracing Intervals	Comments
Top Edge (Lu)	3' 11" o/c	
Bottom Edge (Lu)	19' o/c	

- TJI joists are only analyzed using Maximum Allowable bracing solutions.
- Maximum allowable bracing intervals based on applied load.

Connector: Simpson Strong-Tie

Support	Model	Seat Length	Top Fasteners	Face Fasteners	Member Fasteners	Accessories
1 - Face Mount Hanger	IUS2.06/11.88	2.00"	N/A	10-10dx1.5	2-Strong-Grip	

- Refer to manufacturer notes and instructions for proper installation and use of all connectors.

Vertical Loads	Location	Spacing	Dead (0.90)	Floor Live (1.00)	Snow (1.15)	Comments
1 - Uniform (PSF)	0 to 19' 5"	16"	15.0	40.0	-	Upper floor
2 - Point (PLF)	18' 9 3/4"	16"	323.0	-	538.0	Roof DL=15psf x21.5'=323plf LL=25psf x21.5'=538plf
3 - Point (PLF)	18' 9 3/4"	16"	95.0	-	-	Wall DL=10psf x9.5'=95plf

ForteWEB Software Operator	Job Notes
Mariam Soliman BTL Engineering PS (425) 814-8448 mariam.soliman@bt leng.net	



9/29/2024 5:41:52 PM UTC
 ForteWEB v3.8, Engine: V8.4.1.24, Data: V8.1.6.3
 File Name: Dann Residence

Upper Floor/ Main Wall, UJ-05
1 piece(s) 11 7/8" TJI® 210 @ 16" OC

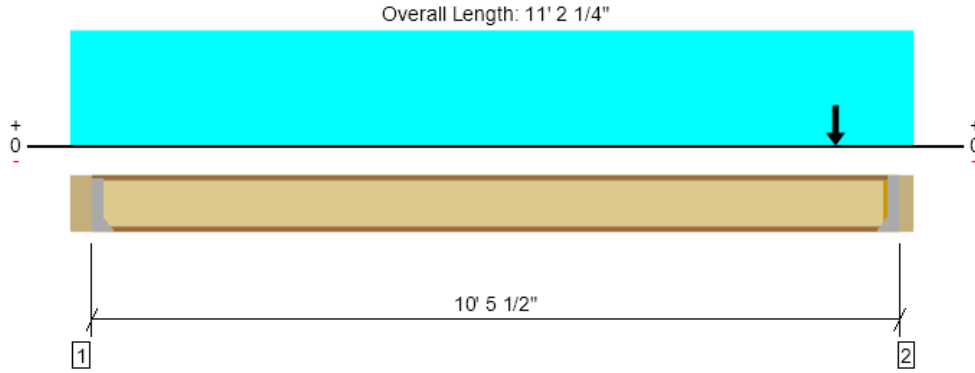

Drawing is Conceptual. All locations are measured from the outside face of left support (or left cantilever end). All dimensions are horizontal (typ.).

Design Results	Actual @ Location	Allowed	Result	LDF	Load: Combination (Pattern)
Member Reaction (lbs)	1322 @ 10' 10 3/4"	1322 (2.31")	Passed (100%)	1.15	1.0 D + 0.75 L + 0.75 S (All Spans)
Shear (lbs)	1322 @ 10' 10 3/4"	1903	Passed (69%)	1.15	1.0 D + 0.75 L + 0.75 S (All Spans)
Moment (Ft-lbs)	1248 @ 6' 3 1/4"	3795	Passed (33%)	1.00	1.0 D + 1.0 L (All Spans)
Live Load Defl. (in)	0.055 @ 5' 10 13/16"	0.261	Passed (L/999+)	--	1.0 D + 0.75 L + 0.75 S (All Spans)
Total Load Defl. (in)	0.093 @ 5' 11 7/16"	0.523	Passed (L/999+)	--	1.0 D + 0.75 L + 0.75 S (All Spans)
TJ-Pro™ Rating	63	40	Passed	--	--

Member Length : 10' 5 1/2"
 System : Floor
 Member Type : Joist
 Building Use : Residential
 Building Code : IBC 2018
 Design Methodology : ASD

- Deflection criteria: LL (L/480) and TL (L/240).
- Allowed moment does not reflect the adjustment for the beam stability factor.
- A structural analysis of the deck has not been performed.
- Deflection analysis is based on composite action with a single layer of 23/32" Weyerhaeuser Edge™ Panel (24" Span Rating) that is glued and nailed down.
- Additional considerations for the TJ-Pro™ Rating include: 5/8" Gypsum ceiling.

Supports	Bearing Length			Loads to Supports (lbs)				Accessories
	Total	Available	Required	Dead	Floor Live	Snow	Factored	
1 - Hanger on 11 7/8" GLB beam	5.25"	Hanger ¹	1.75" / - ²	158	302	57	460	See note ¹
2 - Hanger on 11 7/8" LSL beam	3.50"	Hanger ¹	2.31" / - ²	623	294	660	1339	See note ¹

- At hanger supports, the Total Bearing dimension is equal to the width of the material that is supporting the hanger
- ¹ See Connector grid below for additional information and/or requirements.
- ² Required Bearing Length / Required Bearing Length with Web Stiffeners

Lateral Bracing	Bracing Intervals	Comments
Top Edge (Lu)	6' 5" o/c	
Bottom Edge (Lu)	10' 6" o/c	

- TJI joists are only analyzed using Maximum Allowable bracing solutions.
- Maximum allowable bracing intervals based on applied load.

Connector: Simpson Strong-Tie							
Support	Model	Seat Length	Top Fasteners	Face Fasteners	Member Fasteners	Accessories	
1 - Face Mount Hanger	IUS2.06/11.88	2.00"	N/A	10-10dx1.5	2-Strong-Grip		
2 - Face Mount Hanger	HU2.1/9	2.50"	N/A	14-10dx1.5	6-10dx1.5	Web Stiffeners	

- Refer to manufacturer notes and instructions for proper installation and use of all connectors.

Vertical Loads	Location	Spacing	Dead (0.90)	Floor Live (1.00)	Snow (1.15)	Comments
1 - Uniform (PSF)	0 to 11' 2 1/4"	16"	15.0	40.0	-	Upper floor
2 - Point (PLF)	10' 3/4"	16"	323.0	-	538.0	Roof DL=15psf x21.5'=323plf LL=25psf x21.5'=538plf
3 - Point (PLF)	10' 3/4"	16"	95.0	-	-	Wall DL=10psf x9.5'=95plf

ForteWEB Software Operator	Job Notes
Mariam Soliman BTL Engineering PS (425) 814-8448 mariam.soliman@btleng.net	



9/29/2024 5:41:52 PM UTC
 ForteWEB v3.8, Engine: V8.4.1.24, Data: V8.1.6.3
 File Name: Dann Residence

Upper Floor/ Main Wall, UB-01
1 piece(s) 4 x 8 DF No.2

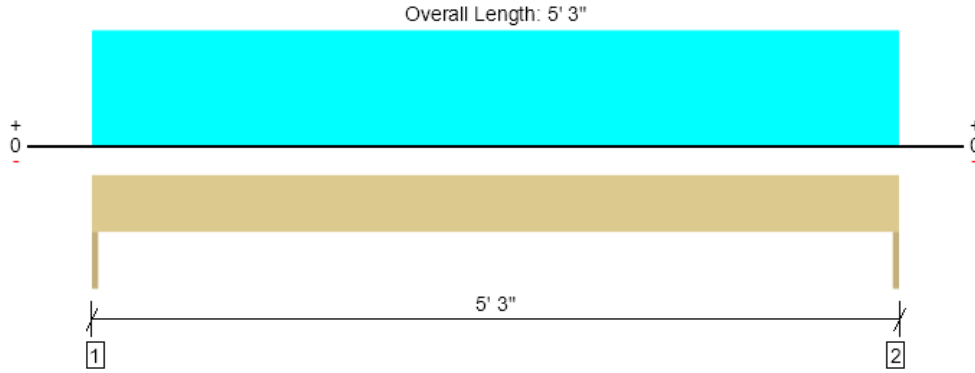

Drawing is Conceptual. All locations are measured from the outside face of left support (or left cantilever end). All dimensions are horizontal (typ.).

Design Results	Actual @ Location	Allowed	Result	LDF	Load: Combination (Pattern)
Member Reaction (lbs)	611 @ 0	3281 (1.50")	Passed (19%)	--	1.0 D + 0.75 L + 0.75 S (All Spans)
Shear (lbs)	441 @ 8 3/4"	3502	Passed (13%)	1.15	1.0 D + 0.75 L + 0.75 S (All Spans)
Moment (Ft-lbs)	802 @ 2' 7 1/2"	3438	Passed (23%)	1.15	1.0 D + 0.75 L + 0.75 S (All Spans)
Live Load Defl. (in)	0.007 @ 2' 7 1/2"	0.131	Passed (L/999+)	--	1.0 D + 0.75 L + 0.75 S (All Spans)
Total Load Defl. (in)	0.022 @ 2' 7 1/2"	0.262	Passed (L/999+)	--	1.0 D + 0.75 L + 0.75 S (All Spans)

Member Length : 5' 3"
 System : Wall
 Member Type : Header
 Building Use : Residential
 Building Code : IBC 2018
 Design Methodology : ASD

- Deflection criteria: LL (L/480) and TL (L/240).
- Allowed moment does not reflect the adjustment for the beam stability factor.
- Applicable calculations are based on NDS.

Supports	Bearing Length			Loads to Supports (lbs)				Accessories
	Total	Available	Required	Dead	Floor Live	Snow	Factored	
1 - Trimmer - HF	1.50"	1.50"	1.50"	411	70	197	611	None
2 - Trimmer - HF	1.50"	1.50"	1.50"	411	70	197	611	None

Lateral Bracing	Bracing Intervals	Comments
Top Edge (Lu)	5' 3" o/c	
Bottom Edge (Lu)	5' 3" o/c	

•Maximum allowable bracing intervals based on applied load.

Vertical Loads	Location	Tributary Width	Dead (0.90)	Floor Live (1.00)	Snow (1.15)	Comments
0 - Self Weight (PLF)	0 to 5' 3"	N/A	6.4	--	--	
1 - Uniform (PSF)	0 to 5' 3"	8"	15.0	40.0	-	Upper Floor
2 - Uniform (PLF)	0 to 5' 3"	N/A	95.0	-	-	Wall
3 - Uniform (PSF)	0 to 5' 3"	3'	15.0	-	25.0	Roof

Weyerhaeuser Notes

Weyerhaeuser warrants that the sizing of its products will be in accordance with Weyerhaeuser product design criteria and published design values. Weyerhaeuser expressly disclaims any other warranties related to the software. Use of this software is not intended to circumvent the need for a design professional as determined by the authority having jurisdiction. The designer of record, builder or framer is responsible to assure that this calculation is compatible with the overall project. Accessories (Rim Board, Blocking Panels and Squash Blocks) are not designed by this software. Products manufactured at Weyerhaeuser facilities are third-party certified to sustainable forestry standards. Weyerhaeuser Engineered Lumber Products have been evaluated by ICC-ES under evaluation reports ESR-1153 and ESR-1387 and/or tested in accordance with applicable ASTM standards. For current code evaluation reports, Weyerhaeuser product literature and installation details refer to www.weyerhaeuser.com/woodproducts/document-library.

The product application, input design loads, dimensions and support information have been provided by ForteWEB Software Operator

ForteWEB Software Operator	Job Notes
Mariam Soliman BTL Engineering PS (425) 814-8448 mariam.soliman@btleng.net	



9/29/2024 5:41:52 PM UTC
 ForteWEB v3.8, Engine: V8.4.1.24, Data: V8.1.6.3
 File Name: Dann Residence

Upper Floor/ Main Wall, UB-02
1 piece(s) 4 x 8 DF No.2

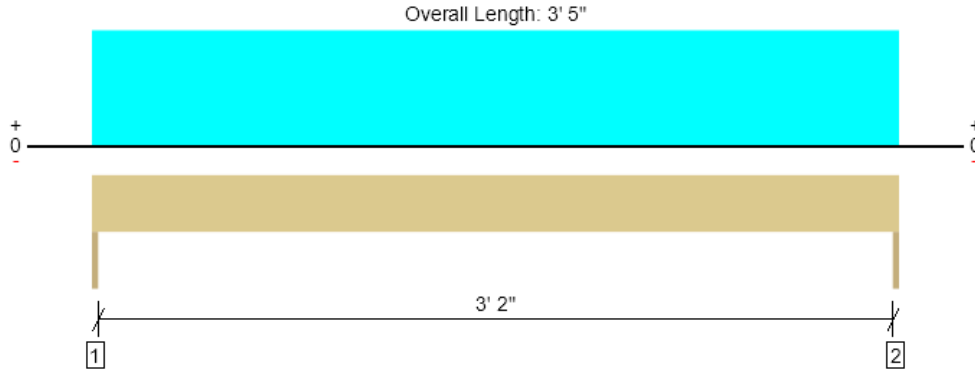

Drawing is Conceptual. All locations are measured from the outside face of left support (or left cantilever end). All dimensions are horizontal (typ.).

Design Results	Actual @ Location	Allowed	Result	LDF	Load: Combination (Pattern)
Member Reaction (lbs)	1290 @ 0	3281 (1.50")	Passed (39%)	--	1.0 D + 0.75 L + 0.75 S (All Spans)
Shear (lbs)	710 @ 8 3/4"	3045	Passed (23%)	1.00	1.0 D + 1.0 L (All Spans)
Moment (Ft-lbs)	1058 @ 1' 8 1/2"	2989	Passed (35%)	1.00	1.0 D + 1.0 L (All Spans)
Live Load Defl. (in)	0.007 @ 1' 8 1/2"	0.085	Passed (L/999+)	--	1.0 D + 0.75 L + 0.75 S (All Spans)
Total Load Defl. (in)	0.013 @ 1' 8 1/2"	0.171	Passed (L/999+)	--	1.0 D + 0.75 L + 0.75 S (All Spans)

Member Length : 3' 5"
 System : Wall
 Member Type : Header
 Building Use : Residential
 Building Code : IBC 2018
 Design Methodology : ASD

- Deflection criteria: LL (L/480) and TL (L/240).
- Allowed moment does not reflect the adjustment for the beam stability factor.
- Applicable calculations are based on NDS.

Supports	Bearing Length			Loads to Supports (lbs)				Accessories
	Total	Available	Required	Dead	Floor Live	Snow	Factored	
1 - Trimmer - HF	1.50"	1.50"	1.50"	575	664	290	1290	None
2 - Trimmer - HF	1.50"	1.50"	1.50"	575	664	290	1290	None

Lateral Bracing	Bracing Intervals	Comments
Top Edge (Lu)	3' 5" o/c	
Bottom Edge (Lu)	3' 5" o/c	

•Maximum allowable bracing intervals based on applied load.

Vertical Loads	Location	Tributary Width	Dead (0.90)	Floor Live (1.00)	Snow (1.15)	Comments
0 - Self Weight (PLF)	0 to 3' 5"	N/A	6.4	--	--	
1 - Uniform (PLF)	0 to 3' 5"	N/A	330.0	388.5	169.5	Linked from: UJ-03, Support 2

Weyerhaeuser Notes

Weyerhaeuser warrants that the sizing of its products will be in accordance with Weyerhaeuser product design criteria and published design values. Weyerhaeuser expressly disclaims any other warranties related to the software. Use of this software is not intended to circumvent the need for a design professional as determined by the authority having jurisdiction. The designer of record, builder or framer is responsible to assure that this calculation is compatible with the overall project. Accessories (Rim Board, Blocking Panels and Squash Blocks) are not designed by this software. Products manufactured at Weyerhaeuser facilities are third-party certified to sustainable forestry standards. Weyerhaeuser Engineered Lumber Products have been evaluated by ICC-ES under evaluation reports ESR-1153 and ESR-1387 and/or tested in accordance with applicable ASTM standards. For current code evaluation reports, Weyerhaeuser product literature and installation details refer to www.weyerhaeuser.com/woodproducts/document-library.

The product application, input design loads, dimensions and support information have been provided by ForteWEB Software Operator

ForteWEB Software Operator	Job Notes
Mariam Soliman BTL Engineering PS (425) 814-8448 mariam.soliman@bt leng.net	



9/29/2024 5:41:52 PM UTC
 ForteWEB v3.8, Engine: V8.4.1.24, Data: V8.1.6.3
 File Name: Dann Residence

Upper Floor/ Main Wall, UB-03
1 piece(s) 5 1/2" x 10 1/2" 24F-V4 DF Glulam

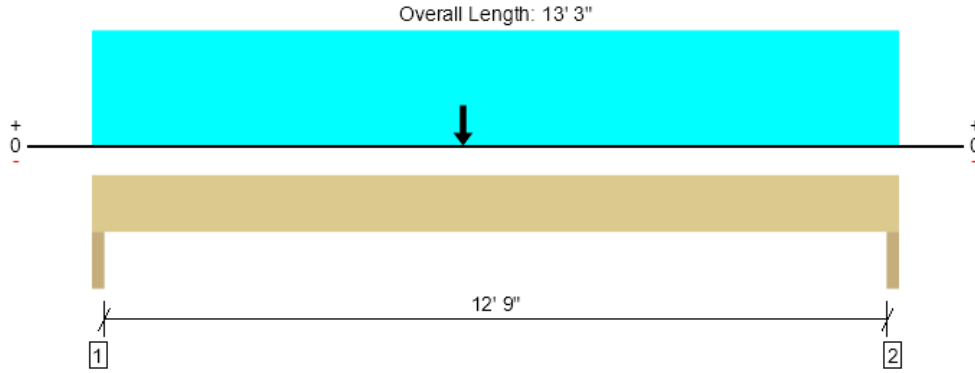

Drawing is Conceptual. All locations are measured from the outside face of left support (or left cantilever end). All dimensions are horizontal (typ.).

Design Results	Actual @ Location	Allowed	Result	LDF	Load: Combination (Pattern)
Member Reaction (lbs)	3675 @ 1 1/2"	10725 (3.00")	Passed (34%)	--	1.0 D + 0.75 L + 0.75 S (All Spans)
Shear (lbs)	3521 @ 1' 1 1/2"	10203	Passed (35%)	1.00	1.0 D + 1.0 L (All Spans)
Pos Moment (Ft-lbs)	19980 @ 6' 1 1/8"	20213	Passed (99%)	1.00	1.0 D + 1.0 L (All Spans)
Live Load Defl. (in)	0.237 @ 6' 6"	0.325	Passed (L/657)	--	1.0 D + 0.75 L + 0.75 S (All Spans)
Total Load Defl. (in)	0.533 @ 6' 6"	0.650	Passed (L/293)	--	1.0 D + 0.75 L + 0.75 S (All Spans)

Member Length : 13' 3"
 System : Floor
 Member Type : Flush Beam
 Building Use : Residential
 Building Code : IBC 2018
 Design Methodology : ASD

- Deflection criteria: LL (L/480) and TL (L/240).
- Allowed moment does not reflect the adjustment for the beam stability factor.
- Critical positive moment adjusted by a volume/size factor of 1.00 that was calculated using length L = 13'.
- The effects of positive or negative camber have not been accounted for when calculating deflection.
- The specified glulam is assumed to have its strong laminations at the bottom of the beam. Install with proper side up as indicated by the manufacturer.
- Applicable calculations are based on NDS.

Supports	Bearing Length			Loads to Supports (lbs)				Accessories
	Total	Available	Required	Dead	Floor Live	Snow	Factored	
1 - Trimmer - HF	3.00"	3.00"	1.50"	2024	1595	607	3675	None
2 - Trimmer - HF	3.00"	3.00"	1.50"	1752	1408	515	3194	None

Lateral Bracing	Bracing Intervals	Comments
Top Edge (Lu)	10' 4" o/c	
Bottom Edge (Lu)	13' 3" o/c	

•Maximum allowable bracing intervals based on applied load.

Vertical Loads	Location (Side)	Tributary Width	Dead (0.90)	Floor Live (1.00)	Snow (1.15)	Comments
0 - Self Weight (PLF)	0 to 13' 3"	N/A	14.0	--	--	
1 - Uniform (PSF)	0 to 13' 3" (Front)	1' 4"	15.0	40.0	-	Upper Floor
2 - Point (lb)	6' 1 1/8" (Front)	N/A	3325	2296	1122	Linked from: UB-08, Support 2

• Side loads are assumed to not induce cross-grain tension.

Weyerhaeuser Notes

Weyerhaeuser warrants that the sizing of its products will be in accordance with Weyerhaeuser product design criteria and published design values. Weyerhaeuser expressly disclaims any other warranties related to the software. Use of this software is not intended to circumvent the need for a design professional as determined by the authority having jurisdiction. The designer of record, builder or framer is responsible to assure that this calculation is compatible with the overall project. Accessories (Rim Board, Blocking Panels and Squash Blocks) are not designed by this software. Products manufactured at Weyerhaeuser facilities are third-party certified to sustainable forestry standards. Weyerhaeuser Engineered Lumber Products have been evaluated by ICC-ES under evaluation reports ESR-1153 and ESR-1387 and/or tested in accordance with applicable ASTM standards. For current code evaluation reports, Weyerhaeuser product literature and installation details refer to www.weyerhaeuser.com/woodproducts/document-library.

The product application, input design loads, dimensions and support information have been provided by ForteWEB Software Operator

ForteWEB Software Operator	Job Notes
Mariam Soliman BTL Engineering PS (425) 814-8448 mariam.soliman@btleng.net	



9/29/2024 5:41:52 PM UTC
 ForteWEB v3.8, Engine: V8.4.1.24, Data: V8.1.6.3
 File Name: Dann Residence

Upper Floor/ Main Wall, UB-04

1 piece(s) 5 1/2" x 19 1/2" 24F-V4 DF Glulam

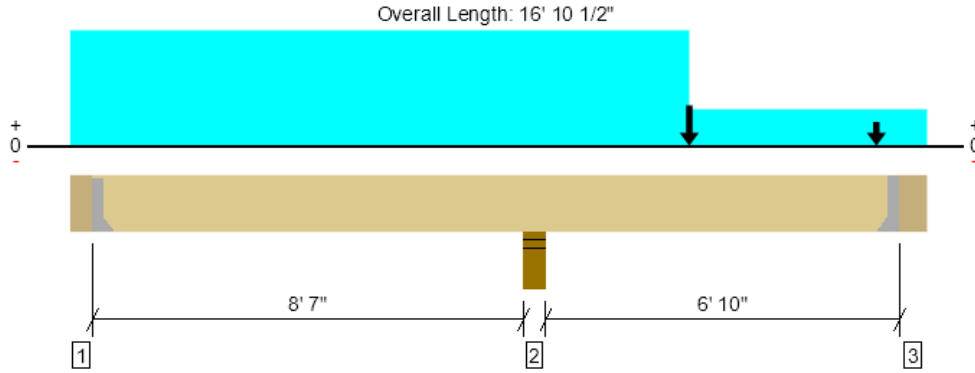

Drawing is Conceptual. All locations are measured from the outside face of left support (or left cantilever end). All dimensions are horizontal (typ.).

Design Results	Actual @ Location	Allowed	Result	LDF	Load: Combination (Pattern)
Member Reaction (lbs)	4730 @ 16' 3 3/4"	5363 (1.50")	Passed (88%)	--	1.0 D + 0.75 L + 0.75 S (Alt Spans)
Shear (lbs)	5721 @ 11' 1 1/4"	21790	Passed (26%)	1.15	1.0 D + 0.75 L + 0.75 S (All Spans)
Pos Moment (Ft-lbs)	9502 @ 12' 3"	80169	Passed (12%)	1.15	1.0 D + 0.75 L + 0.75 S (Alt Spans)
Neg Moment (Ft-lbs)	-9664 @ 9' 3"	53737	Passed (18%)	1.00	1.0 D + 1.0 L (All Spans)
Live Load Defl. (in)	0.009 @ 4' 7 1/16"	0.220	Passed (L/999+)	--	1.0 D + 1.0 L (Alt Spans)
Total Load Defl. (in)	0.011 @ 12' 10 9/16"	0.353	Passed (L/999+)	--	1.0 D + 0.75 L + 0.75 S (Alt Spans)

Member Length : 15' 10 1/2"
 System : Floor
 Member Type : Flush Beam
 Building Use : Residential
 Building Code : IBC 2018
 Design Methodology : ASD

- Deflection criteria: LL (L/480) and TL (L/240).
- Allowed moment does not reflect the adjustment for the beam stability factor.
- Critical positive moment adjusted by a volume/size factor of 1.00 that was calculated using length L = 5' 10 3/4".
- Critical negative moment adjusted by a volume/size factor of 1.00 that was calculated using length L = 3' 11 1/16".
- The effects of positive or negative camber have not been accounted for when calculating deflection.
- The specified glulam is assumed to have its strong laminations at the bottom of the beam. Install with proper side up as indicated by the manufacturer.
- Applicable calculations are based on NDS.

Supports	Bearing Length			Loads to Supports (lbs)				Accessories
	Total	Available	Required	Dead	Floor Live	Snow	Factored	
1 - Hanger on 19 1/2" PSL beam	5.25"	Hanger ¹	1.50"	1383	2434	111/-84	3817	See note ¹
2 - Stud wall - DF	5.50"	5.50"	3.58"	5932	6052	2435	12297	None
3 - Hanger on 19 1/2" GLB beam	6.75"	Hanger ¹	1.50"	2063	1395/-309	2354	4875	See note ¹

- At hanger supports, the Total Bearing dimension is equal to the width of the material that is supporting the hanger
- ¹ See Connector grid below for additional information and/or requirements.

Lateral Bracing	Bracing Intervals	Comments
Top Edge (Lu)	15' 11" o/c	
Bottom Edge (Lu)	15' 11" o/c	

•Maximum allowable bracing intervals based on applied load.

Connector: Simpson Strong-Tie						
Support	Model	Seat Length	Top Fasteners	Face Fasteners	Member Fasteners	Accessories
1 - Face Mount Hanger	HU616	2.50"	N/A	26-16d	12-16d	
3 - Face Mount Hanger	HGUS5.50/14	4.00"	N/A	66-10d	22-10d	

- Refer to manufacturer notes and instructions for proper installation and use of all connectors.

ForteWEB Software Operator	Job Notes
Mariam Soliman BTL Engineering PS (425) 814-8448 mariam.soliman@btleng.net	



9/29/2024 5:41:52 PM UTC
 ForteWEB v3.8, Engine: V8.4.1.24, Data: V8.1.6.3
 File Name: Dann Residence

Vertical Loads	Location (Side)	Tributary Width	Dead (0.90)	Floor Live (1.00)	Snow (1.15)	Comments
0 - Self Weight (PLF)	5 1/4" to 16' 3 3/4"	N/A	26.1	--	--	
1 - Uniform (PSF)	0 to 12' 3" (Front)	9' 7"	25.0	60.0	-	Deck
2 - Uniform (PSF)	12' 3" to 16' 10 1/2" (Front)	5' 9"	15.0	40.0	-	Upper Floor
3 - Uniform (PLF)	0 to 12' 3" (Front)	N/A	105.0	-	-	Wall
4 - Uniform (PSF)	0 to 12' 3" (Front)	2'	15.0	-	25.0	Roof
5 - Point (lb)	15' 10 1/2" (Front)	N/A	831	-	1600	Linked from: RB-06, Support 2
6 - Point (lb)	12' 3" (Front)	N/A	3146	1135	2568	Linked from: UB-05, Support 2

• Side loads are assumed to not induce cross-grain tension.

Weyerhaeuser Notes

Weyerhaeuser warrants that the sizing of its products will be in accordance with Weyerhaeuser product design criteria and published design values. Weyerhaeuser expressly disclaims any other warranties related to the software. Use of this software is not intended to circumvent the need for a design professional as determined by the authority having jurisdiction. The designer of record, builder or framer is responsible to assure that this calculation is compatible with the overall project. Accessories (Rim Board, Blocking Panels and Squash Blocks) are not designed by this software. Products manufactured at Weyerhaeuser facilities are third-party certified to sustainable forestry standards. Weyerhaeuser Engineered Lumber Products have been evaluated by ICC-ES under evaluation reports ESR-1153 and ESR-1387 and/or tested in accordance with applicable ASTM standards. For current code evaluation reports, Weyerhaeuser product literature and installation details refer to www.weyerhaeuser.com/woodproducts/document-library.

The product application, input design loads, dimensions and support information have been provided by ForteWEB Software Operator

ForteWEB Software Operator	Job Notes
Mariam Soliman BTL Engineering PS (425) 814-8448 mariam.soliman@btleng.net	



9/29/2024 5:41:52 PM UTC
ForteWEB v3.8, Engine: V8.4.1.24, Data: V8.1.6.3
File Name: Dann Residence

Upper Floor/ Main Wall, UB-05
1 piece(s) W8X31 (A992) ASTM Steel

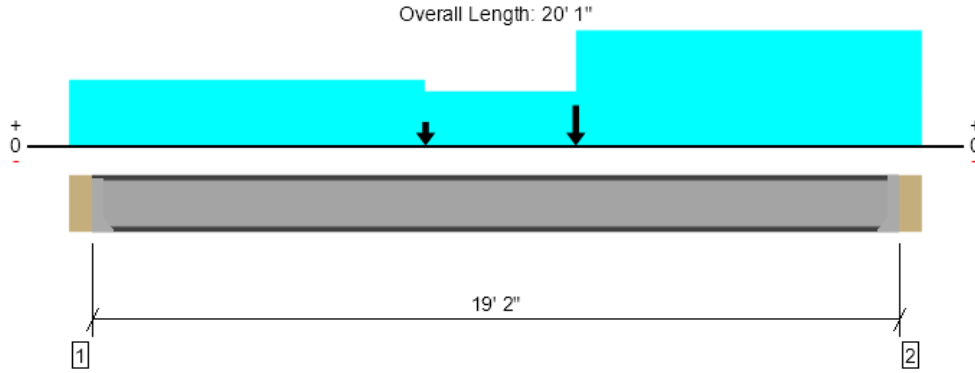

Drawing is Conceptual. All locations are measured from the outside face of left support (or left cantilever end). All dimensions are horizontal (typ.).

Design Results	Actual @ Location	Allowed	Result	LDF	Load: Combination (Pattern)
Member Reaction (lbs)	5923 @ 19' 7 1/2"	31376 (1.50")	Passed (19%)	--	1.0 D + 0.75 L + 0.75 S (All Spans)
Shear (lbs)	5840 @ 19' 7 1/2"	45600	Passed (13%)	--	1.0 D + 0.75 L + 0.75 S (All Spans)
Moment (Ft-lbs)	38565 @ 11' 11 1/2"	56883	Passed (68%)	--	1.0 D + 1.0 S (All Spans)
Live Load Defl. (in)	0.356 @ 10' 3 11/16"	0.479	Passed (L/647)	--	1.0 D + 0.75 L + 0.75 S (All Spans)
Total Load Defl. (in)	0.700 @ 10' 4 1/16"	0.958	Passed (L/328)	--	1.0 D + 0.75 L + 0.75 S (All Spans)

Member Length : 19' 2"
 System : Floor
 Member Type : Flush Beam
 Building Use : Residential
 Building Code : IBC 2018
 Design Methodology : ASD

- Deflection criteria: LL (L/480) and TL (L/240).
- Bearing reinforcement may be required for support located at 0".
- Bearing reinforcement may be required for support located at 19' 2".
- Applicable calculations are based on ANSI/AISC 360-16.
- A lateral-torsional buckling factor (C_b) of 1.0 has been assumed.

Supports	Bearing Length			Loads to Supports (lbs)				Accessories
	Total	Available	Required	Dead	Floor Live	Snow	Factored	
1 - Hanger on 8" GLB beam	5.50"	Hanger ¹	1.50" / - ²	2253	1390	1747	4605	See note ¹
2 - Hanger on 8" GLB beam	5.50"	Hanger ¹	1.50" / - ²	3146	1135	2568	5923	See note ¹

- At hanger supports, the Total Bearing dimension is equal to the width of the material that is supporting the hanger
- ¹ See Connector grid below for additional information and/or requirements.
- ² Required Bearing Length / Required Bearing Length with Web Stiffeners

Lateral Bracing	Bracing Intervals	Comments
Top Edge (Lu)	End Bearing Points	
Bottom Edge (Lu)	End Bearing Points	

Connector: Simpson Strong-Tie							
Support	Model	Seat Length	Top Fasteners	Face Fasteners	Member Fasteners	Accessories	
1 - Face Mount Hanger	Connector not found	N/A	N/A	N/A	N/A		
2 - Face Mount Hanger	Connector not found	N/A	N/A	N/A	N/A		

• Refer to manufacturer notes and instructions for proper installation and use of all connectors.

Vertical Loads	Location (Side)	Tributary Width	Dead (0.90)	Floor Live (1.00)	Snow (1.15)	Comments
0 - Self Weight (PLF)	5 1/2" to 19' 7 1/2"	N/A	31.0	--	--	
1 - Uniform (PSF)	0 to 8' 4 1/4" (Front)	1' 4"	25.0	60.0	-	Upper Floor-Deck
2 - Uniform (PSF)	8' 4 1/4" to 20' 1" (Front)	8"	25.0	60.0	-	Upper Floor-Deck
3 - Uniform (PSF)	8' 4 1/4" to 20' 1" (Front)	8"	15.0	40.0	-	Upper Floor
4 - Uniform (PLF)	11' 11 1/2" to 20' 1" (Front)	N/A	105.0	-	-	Wall
5 - Point (lb)	11' 11 1/2" (Front)	N/A	2623	-	4203	Linked from: RB-06, Support 1
6 - Point (lb)	8' 4 1/2" (Front)	N/A	737	1074	112	Linked from: UB-11, Support 1

• Side loads are assumed to not induce cross-grain tension.

ForteWEB Software Operator	Job Notes
Mariam Soliman BTL Engineering PS (425) 814-8448 mariam.soliman@btleng.net	



9/29/2024 5:41:52 PM UTC
 ForteWEB v3.8, Engine: V8.4.1.24, Data: V8.1.6.3
 File Name: Dann Residence

Upper Floor/ Main Wall, UB-06

1 piece(s) 6 3/4" x 19 1/2" 24F-V4 DF Glulam

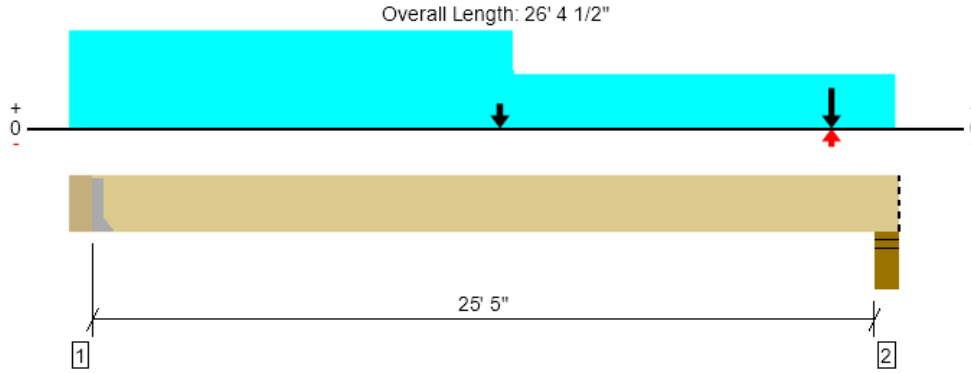

Drawing is Conceptual. All locations are measured from the outside face of left support (or left cantilever end). All dimensions are horizontal (typ.).

Design Results	Actual @ Location	Allowed	Result	LDF	Load: Combination (Pattern) [Group]
Member Reaction (lbs)	11109 @ 5 1/2"	11109 (2.53")	Passed (100%)	--	1.0 D + 0.75 L + 0.75 S (All Spans) [1]
Shear (lbs)	11251 @ 24' 3"	23254	Passed (48%)	1.00	1.0 D + 1.0 L (All Spans) [1]
Pos Moment (Ft-lbs)	71736 @ 13' 4"	77750	Passed (92%)	1.00	1.0 D + 1.0 L (All Spans) [1]
Live Load Defl. (in)	0.608 @ 13' 3 5/8"	0.639	Passed (L/504)	--	1.0 D + 1.0 L (All Spans) [1]
Total Load Defl. (in)	1.094 @ 13' 2 1/4"	1.277	Passed (L/280)	--	1.0 D + 1.0 L (All Spans) [1]

Member Length : 25' 11"
 System : Floor
 Member Type : Flush Beam
 Building Use : Residential
 Building Code : IBC 2018
 Design Methodology : ASD

- Deflection criteria: LL (L/480) and TL (L/240).
- Allowed moment does not reflect the adjustment for the beam stability factor.
- Critical positive moment adjusted by a volume/size factor of 0.91 that was calculated using length L = 25' 6 1/2".
- The effects of positive or negative camber have not been accounted for when calculating deflection.
- The specified glulam is assumed to have its strong laminations at the bottom of the beam. Install with proper side up as indicated by the manufacturer.
- Applicable calculations are based on NDS.

Supports	Bearing Length			Loads to Supports (lbs)				Accessories
	Total	Available	Required	Dead	Floor Live	Snow	Factored	
1 - Hanger on 19 1/2" GLB beam	5.50"	Hanger ¹	2.53"	5306	5808	2441	11492	See note ¹
2 - Stud wall - HF	6.00"	6.00"	4.74"	5483	6920	3047	12958	Blocking

- Blocking Panels are assumed to carry no loads applied directly above them and the full load is applied to the member being designed.
- At hanger supports, the Total Bearing dimension is equal to the width of the material that is supporting the hanger
- ¹ See Connector grid below for additional information and/or requirements.

Lateral Bracing	Bracing Intervals	Comments
Top Edge (Lu)	25' 11" o/c	
Bottom Edge (Lu)	25' 11" o/c	

•Maximum allowable bracing intervals based on applied load.

Connector: Simpson Strong-Tie						
Support	Model	Seat Length	Top Fasteners	Face Fasteners	Member Fasteners	Accessories
1 - Face Mount Hanger	HGUS6.88/14	4.00"	N/A	66-10d	22-10d	

- Refer to manufacturer notes and instructions for proper installation and use of all connectors.

ForteWEB Software Operator	Job Notes
Mariam Soliman BTL Engineering PS (425) 814-8448 mariam.soliman@btleng.net	



9/29/2024 5:41:52 PM UTC
 ForteWEB v3.8, Engine: V8.4.1.24, Data: V8.1.6.3
 File Name: Dann Residence

Vertical Loads	Location (Side)	Tributary Width	Dead (0.90)	Floor Live (1.00)	Snow (1.15)	Comments
0 - Self Weight (PLF)	5 1/2" to 26' 4 1/2"	N/A	32.0	--	--	
1 - Uniform (PLF)	0 to 13' 9 1/2" (Front)	N/A	174.8	391.5	25.5	Linked from: UJ-03, Support 1
2 - Uniform (PLF)	13' 9 1/2" to 26' 3" (Front)	N/A	151.5	390.0	6.8	Linked from: UJ-04, Support 1
3 - Uniform (PLF)	0 to 13' 9" (Front)	N/A	95.0	-	-	Wall
4 - Uniform (PSF)	0 to 13' 9" (Front)	7' 6"	15.0	-	25.0	Roof
5 - Point (lb)	13' 4" (Front)	N/A	737	1074	112	Linked from: UB-11, Support 2
6 - Point (lb)	24' 2" (Front)	N/A	2063	1395/-309	2354	Linked from: UB-04, Support 3

• Side loads are assumed to not induce cross-grain tension.

Weyerhaeuser Notes

Weyerhaeuser warrants that the sizing of its products will be in accordance with Weyerhaeuser product design criteria and published design values. Weyerhaeuser expressly disclaims any other warranties related to the software. Use of this software is not intended to circumvent the need for a design professional as determined by the authority having jurisdiction. The designer of record, builder or framer is responsible to assure that this calculation is compatible with the overall project. Accessories (Rim Board, Blocking Panels and Squash Blocks) are not designed by this software. Products manufactured at Weyerhaeuser facilities are third-party certified to sustainable forestry standards. Weyerhaeuser Engineered Lumber Products have been evaluated by ICC-ES under evaluation reports ESR-1153 and ESR-1387 and/or tested in accordance with applicable ASTM standards. For current code evaluation reports, Weyerhaeuser product literature and installation details refer to www.eyerhaeuser.com/woodproducts/document-library.

The product application, input design loads, dimensions and support information have been provided by ForteWEB Software Operator

ForteWEB Software Operator	Job Notes
Mariam Soliman BTL Engineering PS (425) 814-8448 mariam.soliman@btleng.net	



9/29/2024 5:41:52 PM UTC
ForteWEB v3.8, Engine: V8.4.1.24, Data: V8.1.6.3
File Name: Dann Residence

Upper Floor/ Main Wall, UB-07

1 piece(s) 3 1/2" x 11 7/8" 1.55E TimberStrand® LSL

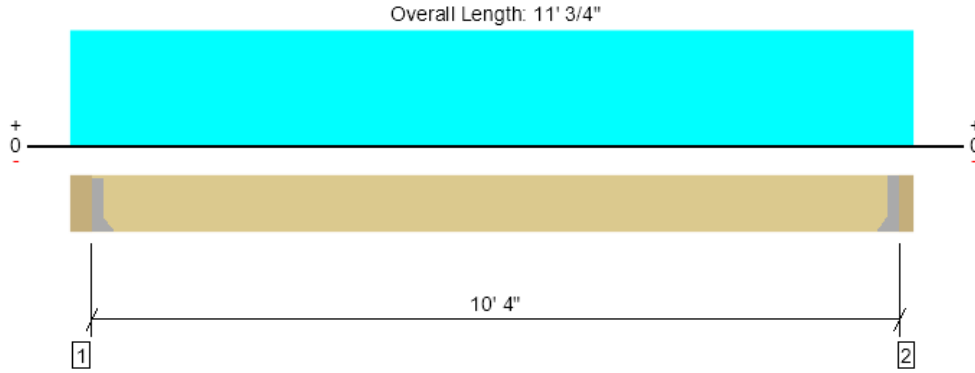

Drawing is Conceptual. All locations are measured from the outside face of left support (or left cantilever end). All dimensions are horizontal (typ.).

Design Results	Actual @ Location	Allowed	Result	LDF	Load: Combination (Pattern)
Member Reaction (lbs)	1236 @ 5 1/4"	4725 (1.50")	Passed (26%)	--	1.0 D + 0.75 L + 0.75 S (All Spans)
Shear (lbs)	999 @ 1' 5 1/8"	9878	Passed (10%)	1.15	1.0 D + 0.75 L + 0.75 S (All Spans)
Moment (Ft-lbs)	3193 @ 5' 7 1/4"	18346	Passed (17%)	1.15	1.0 D + 0.75 L + 0.75 S (All Spans)
Live Load Defl. (in)	0.029 @ 5' 7 1/4"	0.258	Passed (L/999+)	--	1.0 D + 0.75 L + 0.75 S (All Spans)
Total Load Defl. (in)	0.092 @ 5' 7 1/4"	0.517	Passed (L/999+)	--	1.0 D + 0.75 L + 0.75 S (All Spans)

Member Length : 10' 4"
 System : Floor
 Member Type : Flush Beam
 Building Use : Residential
 Building Code : IBC 2018
 Design Methodology : ASD

- Deflection criteria: LL (L/480) and TL (L/240).
- Allowed moment does not reflect the adjustment for the beam stability factor.

Supports	Bearing Length			Loads to Supports (lbs)				Accessories
	Total	Available	Required	Dead	Floor Live	Snow	Factored	
1 - Hanger on 11 7/8" PSL beam	5.25"	Hanger ¹	1.50"	908	149	420	1335	See note ¹
2 - Hanger on 11 7/8" LSL beam	3.50"	Hanger ¹	1.50"	886	146	409	1302	See note ¹

- At hanger supports, the Total Bearing dimension is equal to the width of the material that is supporting the hanger
- ¹ See Connector grid below for additional information and/or requirements.

Lateral Bracing	Bracing Intervals	Comments
Top Edge (Lu)	10' 4" o/c	
Bottom Edge (Lu)	10' 4" o/c	

- Maximum allowable bracing intervals based on applied load.

Connector: Simpson Strong-Tie							
Support	Model	Seat Length	Top Fasteners	Face Fasteners	Member Fasteners	Accessories	
1 - Face Mount Hanger	HU412	2.50"	N/A	16-10dx1.5	6-10d		
2 - Face Mount Hanger	HU412	2.50"	N/A	16-10dx1.5	6-10d		

- Refer to manufacturer notes and instructions for proper installation and use of all connectors.

Vertical Loads	Location (Side)	Tributary Width	Dead (0.90)	Floor Live (1.00)	Snow (1.15)	Comments
0 - Self Weight (PLF)	5 1/4" to 10' 9 1/4"	N/A	13.0	--	--	
1 - Uniform (PSF)	0 to 11' 3/4" (Front)	8"	15.0	40.0	-	Upper Floor
2 - Uniform (PLF)	0 to 11' 3/4" (Front)	N/A	95.0	-	-	Wall
3 - Uniform (PSF)	0 to 11' 3/4" (Front)	3'	15.0	-	25.0	Roof

- Side loads are assumed to not induce cross-grain tension.

Weyerhaeuser Notes
<p>Weyerhaeuser warrants that the sizing of its products will be in accordance with Weyerhaeuser product design criteria and published design values. Weyerhaeuser expressly disclaims any other warranties related to the software. Use of this software is not intended to circumvent the need for a design professional as determined by the authority having jurisdiction. The designer of record, builder or framer is responsible to assure that this calculation is compatible with the overall project. Accessories (Rim Board, Blocking Panels and Squash Blocks) are not designed by this software. Products manufactured at Weyerhaeuser facilities are third-party certified to sustainable forestry standards. Weyerhaeuser Engineered Lumber Products have been evaluated by ICC-ES under evaluation reports ESR-1153 and ESR-1387 and/or tested in accordance with applicable ASTM standards. For current code evaluation reports, Weyerhaeuser product literature and installation details refer to www.weyerhaeuser.com/woodproducts/document-library.</p> <p>The product application, input design loads, dimensions and support information have been provided by ForteWEB Software Operator</p>

ForteWEB Software Operator	Job Notes
<p>Mariam Soliman BTL Engineering PS (425) 814-8448 mariam.soliman@btleng.net</p>	



9/29/2024 5:41:52 PM UTC
 ForteWEB v3.8, Engine: V8.4.1.24, Data: V8.1.6.3
 File Name: Dann Residence

Upper Floor/ Main Wall, UB-08

1 piece(s) 3 1/2" x 11 7/8" 1.55E TimberStrand® LSL

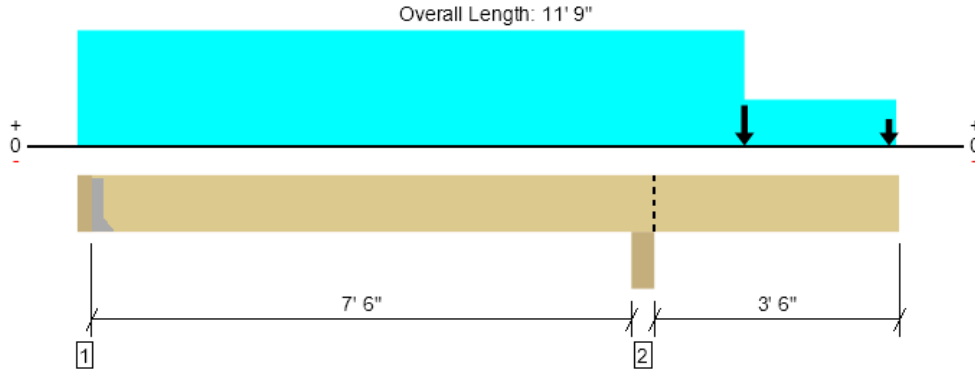

Drawing is Conceptual. All locations are measured from the outside face of left support (or left cantilever end). All dimensions are horizontal (typ.).

Design Results	Actual @ Location	Allowed	Result	LDF	Load: Combination (Pattern)
Member Reaction (lbs)	5889 @ 8' 1/4"	12513 (5.50")	Passed (47%)	--	1.0 D + 0.75 L + 0.75 S (All Spans)
Shear (lbs)	2629 @ 9' 2 7/8"	9878	Passed (27%)	1.15	1.0 D + 0.75 L + 0.75 S (All Spans)
Moment (Ft-lbs)	-6203 @ 8' 1/4"	18346	Passed (34%)	1.15	1.0 D + 0.75 L + 0.75 S (All Spans)
Live Load Defl. (in)	0.058 @ 11' 9"	0.200	Passed (2L/999+)	--	1.0 D + 0.75 L + 0.75 S (Alt Spans)
Total Load Defl. (in)	0.175 @ 11' 9"	0.373	Passed (2L/512)	--	1.0 D + 0.75 L + 0.75 S (Alt Spans)

Member Length : 11' 5 1/2"
 System : Floor
 Member Type : Flush Beam
 Building Use : Residential
 Building Code : IBC 2018
 Design Methodology : ASD

- Deflection criteria: LL (L/480) and TL (L/240).
- Overhang deflection criteria: LL (0.2") and TL (2L/240).
- Allowed moment does not reflect the adjustment for the beam stability factor.

Supports	Bearing Length			Loads to Supports (lbs)				Accessories
	Total	Available	Required	Dead	Floor Live	Snow	Factored	
1 - Hanger on 11 7/8" PSL beam	3.50"	Hanger ¹	1.50"	187	1496/-20	81/-98	1682	See note ¹
2 - Beam - GLB	5.50"	5.50"	2.59"	3325	2296	1122	5889	Blocking

- Blocking Panels are assumed to carry no loads applied directly above them and the full load is applied to the member being designed.
- At hanger supports, the Total Bearing dimension is equal to the width of the material that is supporting the hanger
- ¹ See Connector grid below for additional information and/or requirements.

Lateral Bracing	Bracing Intervals	Comments
Top Edge (Lu)	11' 6" o/c	
Bottom Edge (Lu)	11' 6" o/c	

•Maximum allowable bracing intervals based on applied load.

Connector: Simpson Strong-Tie							
Support	Model	Seat Length	Top Fasteners	Face Fasteners	Member Fasteners	Accessories	
1 - Face Mount Hanger	LUS410	2.00"	N/A	8-16d	6-16d		

- Refer to manufacturer notes and instructions for proper installation and use of all connectors.

Vertical Loads	Location (Side)	Tributary Width	Dead (0.90)	Floor Live (1.00)	Snow (1.15)	Comments
0 - Self Weight (PLF)	3 1/2" to 11' 9"	N/A	13.0	--	--	
1 - Uniform (PSF)	0 to 9' 6" (Front)	3' 4"	15.0	40.0	-	Upper Floor
2 - Uniform (PLF)	0 to 9' 6" (Front)	N/A	118.5	226.5	42.8	Linked from: UJ-05, Support 1
3 - Uniform (PLF)	9' 6" to 11' 8 1/2" (Front)	N/A	95.0	-	-	Wall
4 - Uniform (PSF)	9' 6" to 11' 8 1/2" (Front)	3' 4"	15.0	-	25.0	Roof
5 - Point (lb)	9' 6" (Front)	N/A	908	149	420	Linked from: UB-07, Support 1
6 - Point (lb)	11' 7 1/4" (Front)	N/A	528	99	93	Linked from: UB-14, Support 2

• Side loads are assumed to not induce cross-grain tension.

Forteweb Software Operator	Job Notes
Mariam Soliman BTL Engineering PS (425) 814-8448 mariam.soliman@btleng.net	



9/29/2024 5:41:52 PM UTC
 Forteweb v3.8, Engine: V8.4.1.24, Data: V8.1.6.3
 File Name: Dann Residence

Upper Floor/ Main Wall, UB-09

1 piece(s) 5 1/4" x 11 7/8" 2.2E Parallam® PSL

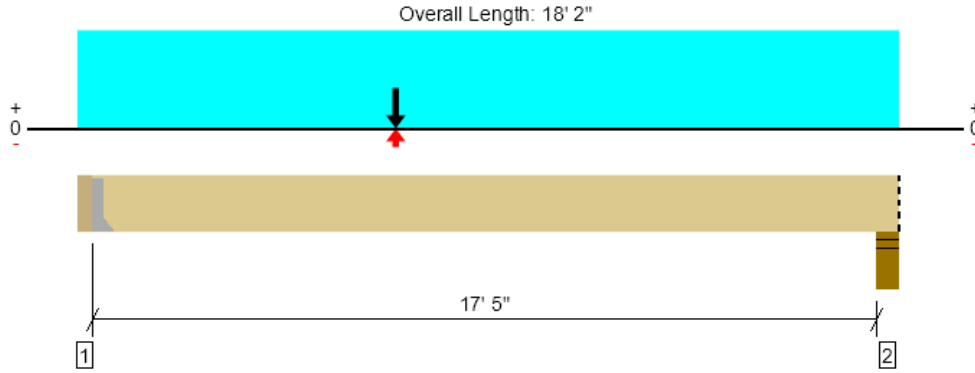

Drawing is Conceptual. All locations are measured from the outside face of left support (or left cantilever end). All dimensions are horizontal (typ.).

Design Results	Actual @ Location	Allowed	Result	LDF	Load: Combination (Pattern) [Group]
Member Reaction (lbs)	1862 @ 3 1/2"	4922 (1.50")	Passed (38%)	--	1.0 D + 1.0 L (All Spans) [1]
Shear (lbs)	1771 @ 1' 3 3/8"	12053	Passed (15%)	1.00	1.0 D + 1.0 L (All Spans) [1]
Moment (Ft-lbs)	10289 @ 6' 10 7/8"	29854	Passed (34%)	1.00	1.0 D + 1.0 L (All Spans) [1]
Live Load Defl. (in)	0.249 @ 8' 7 9/16"	0.439	Passed (L/846)	--	1.0 D + 1.0 L (All Spans) [1]
Total Load Defl. (in)	0.325 @ 8' 8 1/4"	0.877	Passed (L/647)	--	1.0 D + 1.0 L (All Spans) [1]

Member Length : 17' 10 1/2"
 System : Floor
 Member Type : Flush Beam
 Building Use : Residential
 Building Code : IBC 2018
 Design Methodology : ASD

- Deflection criteria: LL (L/480) and TL (L/240).
- Allowed moment does not reflect the adjustment for the beam stability factor.

Supports	Bearing Length			Loads to Supports (lbs)				Accessories
	Total	Available	Required	Dead	Floor Live	Snow	Factored	
1 - Hanger on 11 7/8" PSL beam	3.50"	Hanger ¹	1.50"	469	1415	50/-61	1884	See note ¹
2 - Stud wall - HF	5.50"	5.50"	1.50"	430	1050	31/-37	1480	Blocking

- Blocking Panels are assumed to carry no loads applied directly above them and the full load is applied to the member being designed.
- At hanger supports, the Total Bearing dimension is equal to the width of the material that is supporting the hanger
- ¹ See Connector grid below for additional information and/or requirements.

Lateral Bracing	Bracing Intervals	Comments
Top Edge (Lu)	17' 11" o/c	
Bottom Edge (Lu)	17' 11" o/c	

• Maximum allowable bracing intervals based on applied load.

Connector: Simpson Strong-Tie

Support	Model	Seat Length	Top Fasteners	Face Fasteners	Member Fasteners	Accessories
1 - Face Mount Hanger	U610	2.00"	N/A	14-16d	6-10d	

- Refer to manufacturer notes and instructions for proper installation and use of all connectors.

Vertical Loads	Location (Side)	Tributary Width	Dead (0.90)	Floor Live (1.00)	Snow (1.15)	Comments
0 - Self Weight (PLF)	3 1/2" to 18' 2"	N/A	19.5	--	--	
1 - Uniform (PSF)	0 to 18' 2" (Front)	1' 4"	15.0	40.0	-	Upper Floor
2 - Point (lb)	6' 10 7/8" (Front)	N/A	187	1496/-20	81/-98	Linked from: UB-08, Support 1

• Side loads are assumed to not induce cross-grain tension.

Weyerhaeuser Notes

Weyerhaeuser warrants that the sizing of its products will be in accordance with Weyerhaeuser product design criteria and published design values. Weyerhaeuser expressly disclaims any other warranties related to the software. Use of this software is not intended to circumvent the need for a design professional as determined by the authority having jurisdiction. The designer of record, builder or framer is responsible to assure that this calculation is compatible with the overall project. Accessories (Rim Board, Blocking Panels and Squash Blocks) are not designed by this software. Products manufactured at Weyerhaeuser facilities are third-party certified to sustainable forestry standards. Weyerhaeuser Engineered Lumber Products have been evaluated by ICC-ES under evaluation reports ESR-1153 and ESR-1387 and/or tested in accordance with applicable ASTM standards. For current code evaluation reports, Weyerhaeuser product literature and installation details refer to www.weyerhaeuser.com/woodproducts/document-library.

The product application, input design loads, dimensions and support information have been provided by ForteWEB Software Operator

ForteWEB Software Operator	Job Notes
Mariam Soliman BTL Engineering PS (425) 814-8448 mariam.soliman@btleng.net	



9/29/2024 5:41:52 PM UTC
 ForteWEB v3.8, Engine: V8.4.1.24, Data: V8.1.6.3
 File Name: Dann Residence

Upper Floor/ Main Wall, UB-10

1 piece(s) 5 1/4" x 11 7/8" 2.2E Parallam® PSL

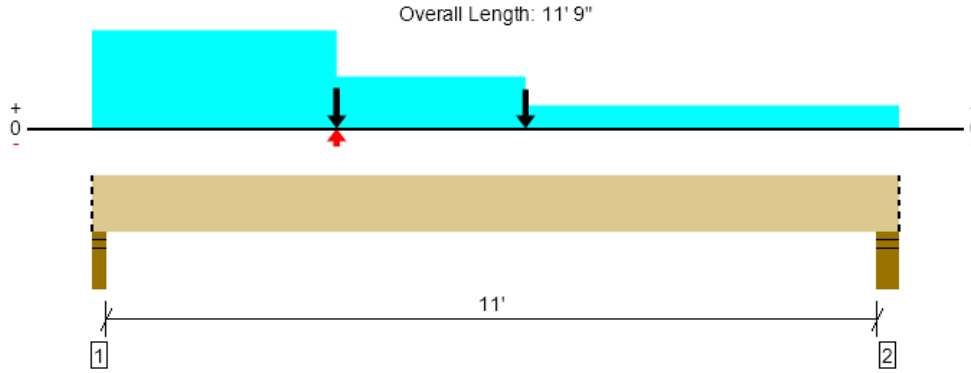

Drawing is Conceptual. All locations are measured from the outside face of left support (or left cantilever end). All dimensions are horizontal (typ.).

Design Results	Actual @ Location	Allowed	Result	LDF	Load: Combination (Pattern) [Group]
Member Reaction (lbs)	5462 @ 2"	7442 (3.50")	Passed (73%)	--	1.0 D + 1.0 L (All Spans) [8]
Shear (lbs)	4450 @ 1' 3 3/8"	12053	Passed (37%)	1.00	1.0 D + 1.0 L (All Spans) [1]
Moment (Ft-lbs)	14220 @ 5' 3 15/16"	29854	Passed (48%)	1.00	1.0 D + 1.0 L (All Spans) [1]
Live Load Defl. (in)	0.156 @ 5' 7 1/16"	0.281	Passed (L/866)	--	1.0 D + 1.0 L (All Spans) [1]
Total Load Defl. (in)	0.220 @ 5' 7 3/16"	0.563	Passed (L/615)	--	1.0 D + 1.0 L (All Spans) [1]

Member Length : 11' 9"
 System : Floor
 Member Type : Flush Beam
 Building Use : Residential
 Building Code : IBC 2018
 Design Methodology : ASD

- Deflection criteria: LL (L/480) and TL (L/240).
- Allowed moment does not reflect the adjustment for the beam stability factor.

Supports	Bearing Length			Loads to Supports (lbs)				Accessories
	Total	Available	Required	Dead	Floor Live	Snow	Factored	
1 - Stud wall - HF	3.50"	3.50"	2.57"	1569	3893	55/-22	5462	Blocking
2 - Stud wall - HF	5.50"	5.50"	1.57"	1002	2328	19/-15	3330	Blocking

• Blocking Panels are assumed to carry no loads applied directly above them and the full load is applied to the member being designed.

Lateral Bracing	Bracing Intervals	Comments
Top Edge (Lu)	11' 9" o/c	
Bottom Edge (Lu)	11' 9" o/c	

•Maximum allowable bracing intervals based on applied load.

Vertical Loads	Location (Side)	Tributary Width	Dead (0.90)	Floor Live (1.00)	Snow (1.15)	Comments
0 - Self Weight (PLF)	0 to 11' 9"	N/A	19.5	--	--	
1 - Uniform (PLF)	0 to 3' 6 3/4" (Front)	N/A	151.5	390.0	6.8	Linked from: UJ-04, Support 1
2 - Uniform (PSF)	3' 6 3/4" to 11' 9" (Front)	3' 4"	15.0	40.0	-	Upper Floor
3 - Uniform (PSF)	0 to 6' 3 3/4" (Front)	4' 2"	15.0	40.0	-	Upper Floor
4 - Point (lb)	6' 3 3/4" (Front)	N/A	530	1273	-	Linked from: UB-15, Support 2
5 - Point (lb)	3' 6 3/4" (Front)	N/A	469	1415	50/-61	Linked from: UB-09, Support 1

• Side loads are assumed to not induce cross-grain tension.

Weyerhaeuser Notes

Weyerhaeuser warrants that the sizing of its products will be in accordance with Weyerhaeuser product design criteria and published design values. Weyerhaeuser expressly disclaims any other warranties related to the software. Use of this software is not intended to circumvent the need for a design professional as determined by the authority having jurisdiction. The designer of record, builder or framer is responsible to assure that this calculation is compatible with the overall project. Accessories (Rim Board, Blocking Panels and Squash Blocks) are not designed by this software. Products manufactured at Weyerhaeuser facilities are third-party certified to sustainable forestry standards. Weyerhaeuser Engineered Lumber Products have been evaluated by ICC-ES under evaluation reports ESR-1153 and ESR-1387 and/or tested in accordance with applicable ASTM standards. For current code evaluation reports, Weyerhaeuser product literature and installation details refer to www.weyerhaeuser.com/woodproducts/document-library.

The product application, input design loads, dimensions and support information have been provided by ForteWEB Software Operator

ForteWEB Software Operator	Job Notes
Mariam Soliman BTL Engineering PS (425) 814-8448 mariam.soliman@btleng.net	



9/29/2024 5:41:52 PM UTC
 ForteWEB v3.8, Engine: V8.4.1.24, Data: V8.1.6.3
 File Name: Dann Residence

Upper Floor/ Main Wall, UB-11

1 piece(s) 3 1/2" x 19 1/2" 24F-V4 DF Glulam

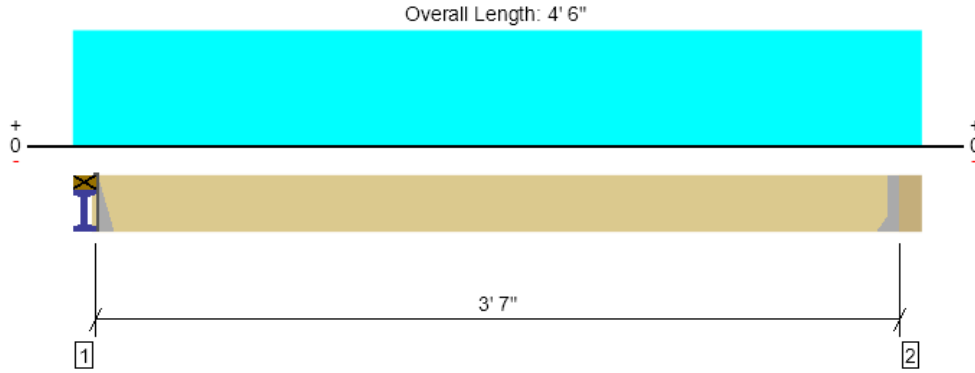

Drawing is Conceptual. All locations are measured from the outside face of left support (or left cantilever end). All dimensions are horizontal (typ.).

Design Results	Actual @ Location	Allowed	Result	LDF	Load: Combination (Pattern)
Member Reaction (lbs)	1448 @ 5 1/2"	3413 (1.50")	Passed (42%)	--	1.0 D + 1.0 L (All Spans)
Shear (lbs)	135 @ 2' 1"	12058	Passed (1%)	1.00	1.0 D + 1.0 L (All Spans)
Pos Moment (Ft-lbs)	1298 @ 2' 3"	44363	Passed (3%)	1.00	1.0 D + 1.0 L (All Spans)
Live Load Defl. (in)	0.000 @ 2' 3"	0.090	Passed (L/999+)	--	1.0 D + 1.0 L (All Spans)
Total Load Defl. (in)	0.001 @ 2' 3"	0.179	Passed (L/999+)	--	1.0 D + 1.0 L (All Spans)

Member Length : 3' 7"
 System : Floor
 Member Type : Flush Beam
 Building Use : Residential
 Building Code : IBC 2018
 Design Methodology : ASD

- Deflection criteria: LL (L/480) and TL (L/240).
- Allowed moment does not reflect the adjustment for the beam stability factor.
- Critical positive moment adjusted by a volume/size factor of 1.00 that was calculated using length L = 3' 7".
- The effects of positive or negative camber have not been accounted for when calculating deflection.
- The specified glulam is assumed to have its strong laminations at the bottom of the beam. Install with proper side up as indicated by the manufacturer.
- Applicable calculations are based on NDS.

Supports	Bearing Length			Loads to Supports (lbs)				Accessories
	Total	Available	Required	Dead	Floor Live	Snow	Factored	
1 - Hanger on Single 2X HF plate	5.50"	Hanger ¹	1.50"	737	1074	112	1811	See note ¹
2 - Hanger on 19 1/2" GLB beam	5.50"	Hanger ¹	1.50"	737	1074	112	1811	See note ¹

- At hanger supports, the Total Bearing dimension is equal to the width of the material that is supporting the hanger
- ¹ See Connector grid below for additional information and/or requirements.

Lateral Bracing	Bracing Intervals	Comments
Top Edge (Lu)	3' 7" o/c	
Bottom Edge (Lu)	3' 7" o/c	

•Maximum allowable bracing intervals based on applied load.

Connector: Simpson Strong-Tie							
Support	Model	Seat Length	Top Fasteners	Face Fasteners	Member Fasteners	Accessories	
1 - Top Mount Hanger	THA426	1.75"	4-10dx1.5	2-16d	6-16d		
2 - Face Mount Hanger	THA413	1.75"	N/A	14-10d	4-10d		

- Refer to manufacturer notes and instructions for proper installation and use of all connectors.

Vertical Loads	Location (Side)	Tributary Width	Dead (0.90)	Floor Live (1.00)	Snow (1.15)	Comments
0 - Self Weight (PLF)	5 1/2" to 4' 1/2"	N/A	16.6	--	--	
1 - Uniform (PSF)	0 to 4' 6" (Front)	4' 1 1/2"	25.0	60.0	-	Upper Floor-Deck
2 - Uniform (PSF)	0 to 4' 6" (Front)	5' 9"	15.0	40.0	-	Upper Floor
3 - Uniform (PLF)	0 to 4' 6" (Front)	N/A	95.0	-	-	Wall
4 - Uniform (PSF)	0 to 4' 6" (Front)	2'	15.0	-	25.0	Roof

- Side loads are assumed to not induce cross-grain tension.

Forteweb Software Operator	Job Notes
Mariam Soliman BTL Engineering PS (425) 814-8448 mariam.soliman@btleng.net	



9/29/2024 5:41:52 PM UTC
 Forteweb v3.8, Engine: V8.4.1.24, Data: V8.1.6.3
 File Name: Dann Residence

Upper Floor/ Main Wall, UB-12
1 piece(s) 5 1/4" x 9 1/2" 2.2E Parallam® PSL

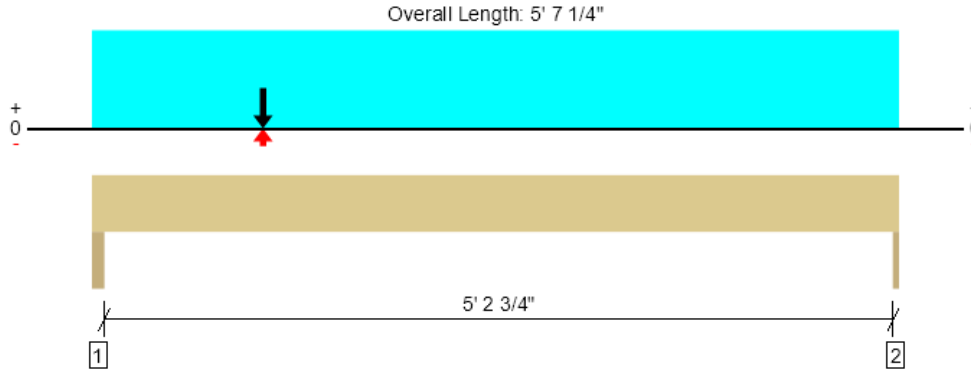

Drawing is Conceptual. All locations are measured from the outside face of left support (or left cantilever end). All dimensions are horizontal (typ.).

Design Results	Actual @ Location	Allowed	Result	LDF	Load: Combination (Pattern) [Group]
Member Reaction (lbs)	5488 @ 1' 1/2"	9844 (3.00")	Passed (56%)	--	1.0 D + 1.0 L (All Spans) [1]
Shear (lbs)	5104 @ 1' 1/2"	9643	Passed (53%)	1.00	1.0 D + 1.0 L (All Spans) [1]
Moment (Ft-lbs)	5574 @ 1' 2 1/4"	19585	Passed (28%)	1.00	1.0 D + 1.0 L (All Spans) [1]
Live Load Defl. (in)	0.027 @ 2' 7 7/16"	0.137	Passed (L/999+)	--	1.0 D + 1.0 L (All Spans) [1]
Total Load Defl. (in)	0.041 @ 2' 7 3/8"	0.274	Passed (L/999+)	--	1.0 D + 1.0 L (All Spans) [1]

Member Length : 5' 7 1/4"
 System : Wall
 Member Type : Header
 Building Use : Residential
 Building Code : IBC 2018
 Design Methodology : ASD

- Deflection criteria: LL (L/480) and TL (L/240).
- Allowed moment does not reflect the adjustment for the beam stability factor.

Supports	Bearing Length			Loads to Supports (lbs)				Accessories
	Total	Available	Required	Dead	Floor Live	Snow	Factored	
1 - Trimmer - HF	3.00"	3.00"	1.67"	1845	3644	89/-68	5488	None
2 - Trimmer - HF	1.50"	1.50"	1.50"	673	1403	22/-16	2076	None

Lateral Bracing	Bracing Intervals	Comments
Top Edge (Lu)	5' 7" o/c	
Bottom Edge (Lu)	5' 7" o/c	

•Maximum allowable bracing intervals based on applied load.

Vertical Loads	Location	Tributary Width	Dead (0.90)	Floor Live (1.00)	Snow (1.15)	Comments
0 - Self Weight (PLF)	0 to 5' 7 1/4"	N/A	15.6	--	--	
1 - Uniform (PSF)	0 to 5' 7 1/4"	6' 5"	15.0	40.0	-	Upper Floor
2 - Point (lb)	1' 2 1/4"	N/A	508	1174	-	Linked from: UB-20, Support 2
3 - Point (lb)	1' 2 1/4"	N/A	1383	2434	111/-84	Linked from: UB-04, Support 1

Weyerhaeuser Notes

Weyerhaeuser warrants that the sizing of its products will be in accordance with Weyerhaeuser product design criteria and published design values. Weyerhaeuser expressly disclaims any other warranties related to the software. Use of this software is not intended to circumvent the need for a design professional as determined by the authority having jurisdiction. The designer of record, builder or framer is responsible to assure that this calculation is compatible with the overall project. Accessories (Rim Board, Blocking Panels and Squash Blocks) are not designed by this software. Products manufactured at Weyerhaeuser facilities are third-party certified to sustainable forestry standards. Weyerhaeuser Engineered Lumber Products have been evaluated by ICC-ES under evaluation reports ESR-1153 and ESR-1387 and/or tested in accordance with applicable ASTM standards. For current code evaluation reports, Weyerhaeuser product literature and installation details refer to www.weyerhaeuser.com/woodproducts/document-library.

The product application, input design loads, dimensions and support information have been provided by ForteWEB Software Operator

ForteWEB Software Operator	Job Notes
Mariam Soliman BTL Engineering PS (425) 814-8448 mariam.soliman@btleng.net	



9/29/2024 5:41:52 PM UTC
 ForteWEB v3.8, Engine: V8.4.1.24, Data: V8.1.6.3
 File Name: Dann Residence

Upper Floor/ Main Wall, UB-13

1 piece(s) 3 1/2" x 9 1/2" 1.55E TimberStrand® LSL

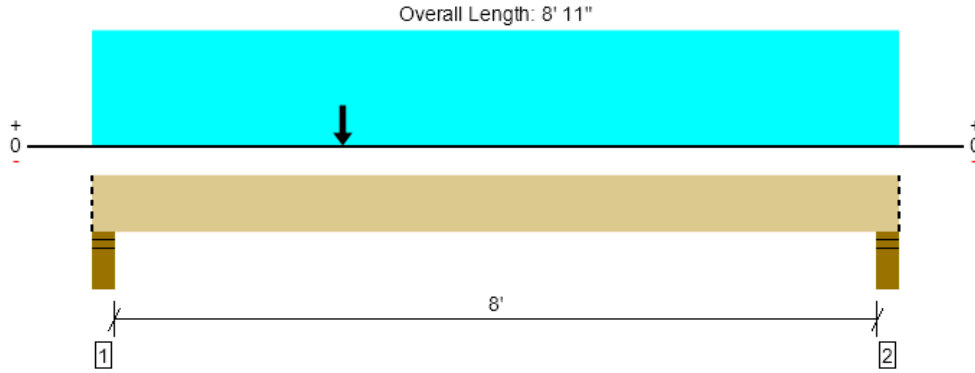

Drawing is Conceptual. All locations are measured from the outside face of left support (or left cantilever end). All dimensions are horizontal (typ.).

Design Results	Actual @ Location	Allowed	Result	LDF	Load: Combination (Pattern)
Member Reaction (lbs)	3548 @ 4"	7796 (5.50")	Passed (46%)	--	1.0 D + 0.75 L + 0.75 S (All Spans)
Shear (lbs)	2842 @ 1' 3"	7902	Passed (36%)	1.15	1.0 D + 0.75 L + 0.75 S (All Spans)
Moment (Ft-lbs)	6752 @ 3' 8 3/8"	11985	Passed (56%)	1.15	1.0 D + 0.75 L + 0.75 S (All Spans)
Live Load Defl. (in)	0.123 @ 4' 3 3/4"	0.206	Passed (L/807)	--	1.0 D + 0.75 L + 0.75 S (All Spans)
Total Load Defl. (in)	0.241 @ 4' 4 1/8"	0.412	Passed (L/410)	--	1.0 D + 0.75 L + 0.75 S (All Spans)

Member Length : 8' 11"
 System : Floor
 Member Type : Flush Beam
 Building Use : Residential
 Building Code : IBC 2018
 Design Methodology : ASD

- Deflection criteria: LL (L/480) and TL (L/240).
- Allowed moment does not reflect the adjustment for the beam stability factor.

Supports	Bearing Length			Loads to Supports (lbs)				Accessories
	Total	Available	Required	Dead	Floor Live	Snow	Factored	
1 - Stud wall - HF	5.50"	5.50"	2.50"	1743	1181	1226	3548	Blocking
2 - Stud wall - HF	5.50"	5.50"	2.08"	1525	677	1226	2952	Blocking

• Blocking Panels are assumed to carry no loads applied directly above them and the full load is applied to the member being designed.

Lateral Bracing	Bracing Intervals	Comments
Top Edge (Lu)	8' 11" o/c	
Bottom Edge (Lu)	8' 11" o/c	

•Maximum allowable bracing intervals based on applied load.

Vertical Loads	Location (Side)	Tributary Width	Dead (0.90)	Floor Live (1.00)	Snow (1.15)	Comments
0 - Self Weight (PLF)	0 to 8' 11"	N/A	10.4	--	--	
1 - Uniform (PSF)	0 to 8' 11" (Front)	1' 9"	15.0	40.0	-	Upper Floor
2 - Uniform (PLF)	0 to 8' 11" (Front)	N/A	105.0	-	-	Wall
3 - Uniform (PSF)	0 to 8' 11" (Front)	11'	15.0	-	25.0	Roof
4 - Point (lb)	2' 9 1/4" (Front)	N/A	533	1234	-	Linked from: UB-20, Support 1

• Side loads are assumed to not induce cross-grain tension.

Weyerhaeuser Notes

Weyerhaeuser warrants that the sizing of its products will be in accordance with Weyerhaeuser product design criteria and published design values. Weyerhaeuser expressly disclaims any other warranties related to the software. Use of this software is not intended to circumvent the need for a design professional as determined by the authority having jurisdiction. The designer of record, builder or framer is responsible to assure that this calculation is compatible with the overall project. Accessories (Rim Board, Blocking Panels and Squash Blocks) are not designed by this software. Products manufactured at Weyerhaeuser facilities are third-party certified to sustainable forestry standards. Weyerhaeuser Engineered Lumber Products have been evaluated by ICC-ES under evaluation reports ESR-1153 and ESR-1387 and/or tested in accordance with applicable ASTM standards. For current code evaluation reports, Weyerhaeuser product literature and installation details refer to www.weyerhaeuser.com/woodproducts/document-library.

The product application, input design loads, dimensions and support information have been provided by ForteWEB Software Operator

ForteWEB Software Operator	Job Notes
Mariam Soliman BTL Engineering PS (425) 814-8448 mariam.soliman@btleng.net	



9/29/2024 5:41:52 PM UTC
 ForteWEB v3.8, Engine: V8.4.1.24, Data: V8.1.6.3
 File Name: Dann Residence

Upper Floor/ Main Wall, UB-14

1 piece(s) 3 1/2" x 11 7/8" 1.55E TimberStrand® LSL

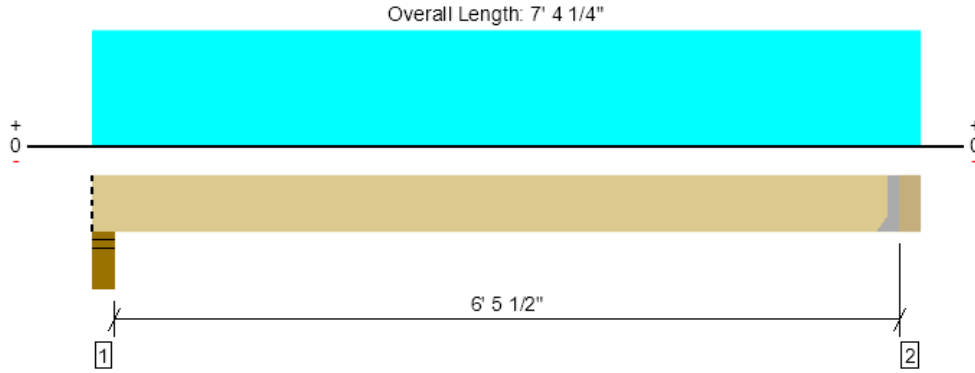

Drawing is Conceptual. All locations are measured from the outside face of left support (or left cantilever end). All dimensions are horizontal (typ.).

Design Results	Actual @ Location	Allowed	Result	LDF	Load: Combination (Pattern)
Member Reaction (lbs)	598 @ 6' 11"	4725 (1.50")	Passed (13%)	--	1.0 D + 0.75 L + 0.75 S (All Spans)
Shear (lbs)	391 @ 5' 11 1/8"	8590	Passed (5%)	1.00	1.0 D + 1.0 L (All Spans)
Moment (Ft-lbs)	919 @ 3' 7 1/2"	15953	Passed (6%)	1.00	1.0 D + 1.0 L (All Spans)
Live Load Defl. (in)	0.003 @ 3' 7 1/2"	0.165	Passed (L/999+)	--	1.0 D + 0.75 L + 0.75 S (All Spans)
Total Load Defl. (in)	0.014 @ 3' 7 1/2"	0.329	Passed (L/999+)	--	1.0 D + 0.75 L + 0.75 S (All Spans)

Member Length : 6' 11"
 System : Floor
 Member Type : Flush Beam
 Building Use : Residential
 Building Code : IBC 2018
 Design Methodology : ASD

- Deflection criteria: LL (L/480) and TL (L/240).
- Allowed moment does not reflect the adjustment for the beam stability factor.

Supports	Bearing Length			Loads to Supports (lbs)				Accessories
	Total	Available	Required	Dead	Floor Live	Snow	Factored	
1 - Stud wall - HF	5.50"	5.50"	1.50"	518	97	91	659	Blocking
2 - Hanger on 11 7/8" PSL beam	5.25"	Hanger ¹	1.50"	528	99	93	672	See note ¹

- Blocking Panels are assumed to carry no loads applied directly above them and the full load is applied to the member being designed.
- At hanger supports, the Total Bearing dimension is equal to the width of the material that is supporting the hanger
- ¹ See Connector grid below for additional information and/or requirements.

Lateral Bracing	Bracing Intervals	Comments
Top Edge (Lu)	6' 11" o/c	
Bottom Edge (Lu)	6' 11" o/c	

•Maximum allowable bracing intervals based on applied load.

Connector: Simpson Strong-Tie

Support	Model	Seat Length	Top Fasteners	Face Fasteners	Member Fasteners	Accessories
2 - Face Mount Hanger	HU412	2.50"	N/A	16-10dx1.5	6-10d	

- Refer to manufacturer notes and instructions for proper installation and use of all connectors.

Vertical Loads	Location (Side)	Tributary Width	Dead (0.90)	Floor Live (1.00)	Snow (1.15)	Comments
0 - Self Weight (PLF)	0 to 6' 11"	N/A	13.0	--	--	
1 - Uniform (PSF)	0 to 7' 4 1/4" (Front)	8"	15.0	40.0	-	Upper Floor
2 - Uniform (PLF)	0 to 7' 4 1/4" (Front)	N/A	105.0	-	-	Wall
3 - Uniform (PSF)	0 to 7' 4 1/4" (Front)	1'	15.0	-	25.0	Roof

• Side loads are assumed to not induce cross-grain tension.

Weyerhaeuser Notes

Weyerhaeuser warrants that the sizing of its products will be in accordance with Weyerhaeuser product design criteria and published design values. Weyerhaeuser expressly disclaims any other warranties related to the software. Use of this software is not intended to circumvent the need for a design professional as determined by the authority having jurisdiction. The designer of record, builder or framer is responsible to assure that this calculation is compatible with the overall project. Accessories (Rim Board, Blocking Panels and Squash Blocks) are not designed by this software. Products manufactured at Weyerhaeuser facilities are third-party certified to sustainable forestry standards. Weyerhaeuser Engineered Lumber Products have been evaluated by ICC-ES under evaluation reports ESR-1153 and ESR-1387 and/or tested in accordance with applicable ASTM standards. For current code evaluation reports, Weyerhaeuser product literature and installation details refer to www.weyerhaeuser.com/woodproducts/document-library.

The product application, input design loads, dimensions and support information have been provided by ForteWEB Software Operator

ForteWEB Software Operator	Job Notes
Mariam Soliman BTL Engineering PS (425) 814-8448 mariam.soliman@btleng.net	



9/29/2024 5:41:52 PM UTC
 ForteWEB v3.8, Engine: V8.4.1.24, Data: V8.1.6.3
 File Name: Dann Residence

Upper Floor/ Main Wall, UB-15

1 piece(s) 3 1/2" x 11 7/8" 1.55E TimberStrand® LSL

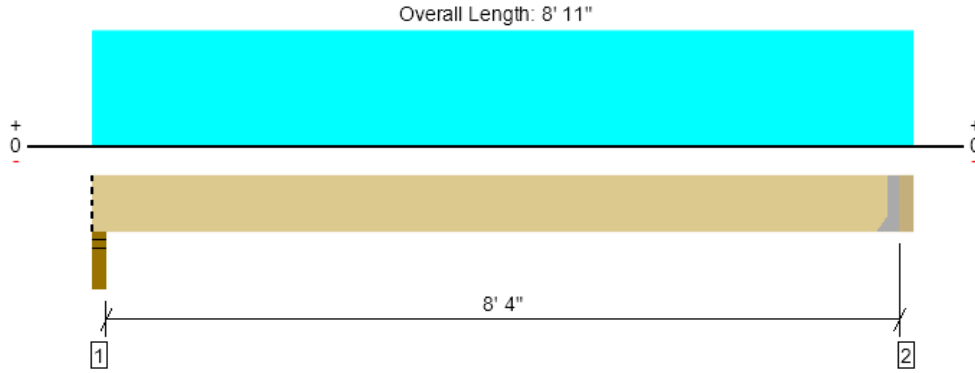

Drawing is Conceptual. All locations are measured from the outside face of left support (or left cantilever end). All dimensions are horizontal (typ.).

Design Results	Actual @ Location	Allowed	Result	LDF	Load: Combination (Pattern)
Member Reaction (lbs)	1690 @ 8' 7 1/2"	4725 (1.50")	Passed (36%)	--	1.0 D + 1.0 L (All Spans)
Shear (lbs)	1295 @ 7' 7 5/8"	8590	Passed (15%)	1.00	1.0 D + 1.0 L (All Spans)
Moment (Ft-lbs)	3574 @ 4' 4 3/4"	15953	Passed (22%)	1.00	1.0 D + 1.0 L (All Spans)
Live Load Defl. (in)	0.052 @ 4' 4 3/4"	0.211	Passed (L/999+)	--	1.0 D + 1.0 L (All Spans)
Total Load Defl. (in)	0.074 @ 4' 4 3/4"	0.423	Passed (L/999+)	--	1.0 D + 1.0 L (All Spans)

Member Length : 8' 7 1/2"
 System : Floor
 Member Type : Flush Beam
 Building Use : Residential
 Building Code : IBC 2018
 Design Methodology : ASD

- Deflection criteria: LL (L/480) and TL (L/240).
- Allowed moment does not reflect the adjustment for the beam stability factor.

Supports	Bearing Length			Loads to Supports (lbs)			Accessories
	Total	Available	Required	Dead	Floor Live	Factored	
1 - Stud wall - HF	3.50"	3.50"	1.50"	519	1238	1757	Blocking
2 - Hanger on 11 7/8" LSL beam	3.50"	Hanger ¹	1.50"	530	1273	1803	See note ¹

- Blocking Panels are assumed to carry no loads applied directly above them and the full load is applied to the member being designed.
- At hanger supports, the Total Bearing dimension is equal to the width of the material that is supporting the hanger
- ¹ See Connector grid below for additional information and/or requirements.

Lateral Bracing	Bracing Intervals	Comments
Top Edge (Lu)	8' 8" o/c	
Bottom Edge (Lu)	8' 8" o/c	

•Maximum allowable bracing intervals based on applied load.

Connector: Simpson Strong-Tie

Support	Model	Seat Length	Top Fasteners	Face Fasteners	Member Fasteners	Accessories
2 - Face Mount Hanger	LUS410	2.00"	N/A	8-16d	6-16d	

- Refer to manufacturer notes and instructions for proper installation and use of all connectors.

Vertical Loads	Location (Side)	Tributary Width	Dead (0.90)	Floor Live (1.00)	Comments
0 - Self Weight (PLF)	0 to 8' 7 1/2"	N/A	13.0	--	
1 - Uniform (PSF)	0 to 8' 11" (Front)	8"	15.0	40.0	Upper Floor
2 - Uniform (PLF)	0 to 8' 11" (Front)	N/A	95.0	255.0	Stairs

• Side loads are assumed to not induce cross-grain tension.

Weyerhaeuser Notes

Weyerhaeuser warrants that the sizing of its products will be in accordance with Weyerhaeuser product design criteria and published design values. Weyerhaeuser expressly disclaims any other warranties related to the software. Use of this software is not intended to circumvent the need for a design professional as determined by the authority having jurisdiction. The designer of record, builder or framer is responsible to assure that this calculation is compatible with the overall project. Accessories (Rim Board, Blocking Panels and Squash Blocks) are not designed by this software. Products manufactured at Weyerhaeuser facilities are third-party certified to sustainable forestry standards. Weyerhaeuser Engineered Lumber Products have been evaluated by ICC-ES under evaluation reports ESR-1153 and ESR-1387 and/or tested in accordance with applicable ASTM standards. For current code evaluation reports, Weyerhaeuser product literature and installation details refer to www.weyerhaeuser.com/woodproducts/document-library.

The product application, input design loads, dimensions and support information have been provided by ForteWEB Software Operator

ForteWEB Software Operator	Job Notes
Mariam Soliman BTL Engineering PS (425) 814-8448 mariam.soliman@btleng.net	



9/29/2024 5:41:52 PM UTC
 ForteWEB v3.8, Engine: V8.4.1.24, Data: V8.1.6.3
 File Name: Dann Residence

Upper Floor/ Main Wall, UB-16
1 piece(s) 5 1/2" x 19 1/2" 24F-V4 DF Glulam

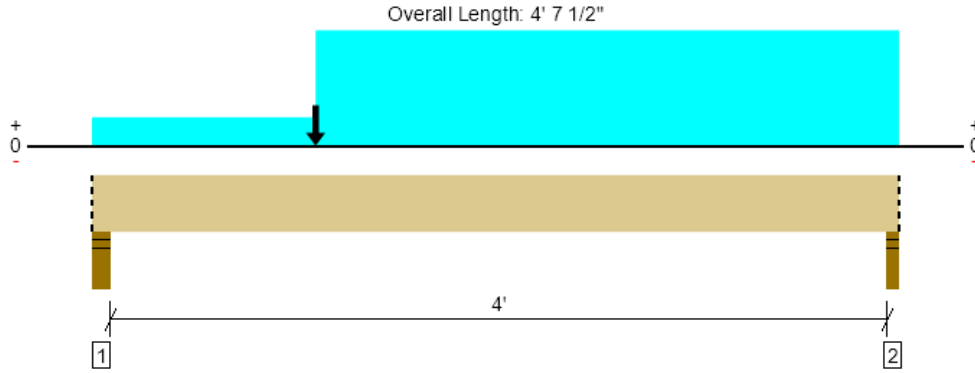

Drawing is Conceptual. All locations are measured from the outside face of left support (or left cantilever end). All dimensions are horizontal (typ.).

Design Results	Actual @ Location	Allowed	Result	LDF	Load: Combination (Pattern)
Member Reaction (lbs)	9091 @ 3"	10024 (4.50")	Passed (91%)	--	1.0 D + 0.75 L + 0.75 S (All Spans)
Shear (lbs)	4807 @ 2'	18948	Passed (25%)	1.00	1.0 D + 1.0 L (All Spans)
Pos Moment (Ft-lbs)	9034 @ 1' 3 3/8"	69713	Passed (13%)	1.00	1.0 D + 1.0 L (All Spans)
Live Load Defl. (in)	0.002 @ 2' 1 15/16"	0.106	Passed (L/999+)	--	1.0 D + 0.75 L + 0.75 S (All Spans)
Total Load Defl. (in)	0.004 @ 2' 2 1/16"	0.213	Passed (L/999+)	--	1.0 D + 0.75 L + 0.75 S (All Spans)

Member Length : 4' 7 1/2"
 System : Floor
 Member Type : Flush Beam
 Building Use : Residential
 Building Code : IBC 2018
 Design Methodology : ASD

- Deflection criteria: LL (L/480) and TL (L/240).
- Allowed moment does not reflect the adjustment for the beam stability factor.
- Critical positive moment adjusted by a volume/size factor of 1.00 that was calculated using length L = 4' 3".
- The effects of positive or negative camber have not been accounted for when calculating deflection.
- The specified glulam is assumed to have its strong laminations at the bottom of the beam. Install with proper side up as indicated by the manufacturer.
- Applicable calculations are based on NDS.

Supports	Bearing Length			Loads to Supports (lbs)					Accessories
	Total	Available	Required	Dead	Floor Live	Roof Live	Snow	Factored	
1 - Stud wall - HF	4.50"	4.50"	4.08"	4311	4525	91	1849	9091	Blocking
2 - Stud wall - HF	3.00"	3.00"	1.50"	1710	1529	159	592	3301	Blocking

• Blocking Panels are assumed to carry no loads applied directly above them and the full load is applied to the member being designed.

Lateral Bracing	Bracing Intervals	Comments
Top Edge (Lu)	4' 8" o/c	
Bottom Edge (Lu)	4' 8" o/c	

•Maximum allowable bracing intervals based on applied load.

Vertical Loads	Location (Side)	Tributary Width	Dead (0.90)	Floor Live (1.00)	Roof Live (1.25)	Snow (1.15)	Comments
0 - Self Weight (PLF)	0 to 4' 7 1/2"	N/A	26.1	--	--	--	
1 - Uniform (PSF)	0 to 4' 7 1/2" (Front)	1' 4"	15.0	40.0	-	-	Upper Floor
2 - Uniform (PLF)	1' 3 3/8" to 4' 7 1/2" (Front)	N/A	105.0	-	-	-	Wall
3 - Uniform (PSF)	1' 3 3/8" to 4' 7 1/2" (Front)	3'	15.0	-	25.0	-	Roof
4 - Point (lb)	1' 3 3/8" (Front)	N/A	5306	5808	-	2441	Linked from: UB-06, Support 1

• Side loads are assumed to not induce cross-grain tension.

Weyerhaeuser Notes

Weyerhaeuser warrants that the sizing of its products will be in accordance with Weyerhaeuser product design criteria and published design values. Weyerhaeuser expressly disclaims any other warranties related to the software. Use of this software is not intended to circumvent the need for a design professional as determined by the authority having jurisdiction. The designer of record, builder or framer is responsible to assure that this calculation is compatible with the overall project. Accessories (Rim Board, Blocking Panels and Squash Blocks) are not designed by this software. Products manufactured at Weyerhaeuser facilities are third-party certified to sustainable forestry standards. Weyerhaeuser Engineered Lumber Products have been evaluated by ICC-ES under evaluation reports ESR-1153 and ESR-1387 and/or tested in accordance with applicable ASTM standards. For current code evaluation reports, Weyerhaeuser product literature and installation details refer to www.weyerhaeuser.com/woodproducts/document-library.

The product application, input design loads, dimensions and support information have been provided by ForteWEB Software Operator

ForteWEB Software Operator	Job Notes
Mariam Soliman BTL Engineering PS (425) 814-8448 mariam.soliman@btleng.net	



9/29/2024 5:41:52 PM UTC
 ForteWEB v3.8, Engine: V8.4.1.24, Data: V8.1.6.3
 File Name: Dann Residence

Upper Floor/ Main Wall, UB-17

1 piece(s) 3 1/2" x 11 7/8" 1.55E TimberStrand® LSL

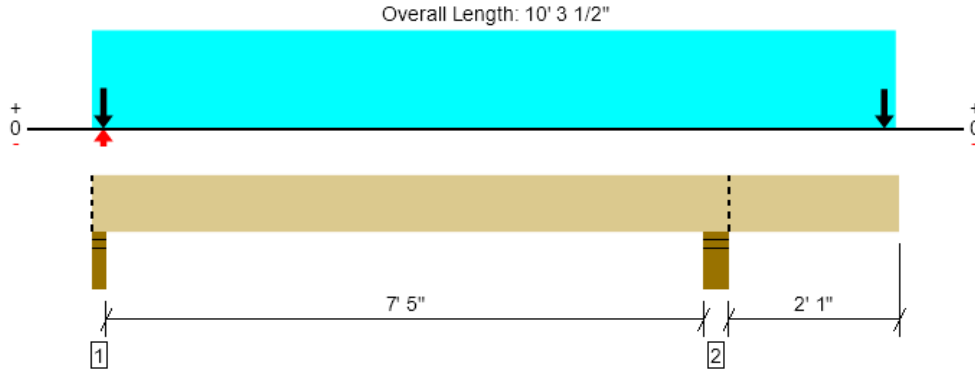

Drawing is Conceptual. All locations are measured from the outside face of left support (or left cantilever end). All dimensions are horizontal (typ.).

Design Results	Actual @ Location	Allowed	Result	LDF	Load: Combination (Pattern) [Group]
Member Reaction (lbs)	8350 @ 7' 11 1/2"	8505 (6.00")	Passed (98%)	--	1.0 D + 0.75 L + 0.75 S (All Spans) [1]
Shear (lbs)	3415 @ 6' 8 5/8"	9878	Passed (35%)	1.15	1.0 D + 0.75 L + 0.75 S (All Spans) [1]
Moment (Ft-lbs)	5828 @ 3' 6 5/8"	18346	Passed (32%)	1.15	1.0 D + 0.75 L + 0.75 S (Alt Spans) [1]
Live Load Defl. (in)	0.066 @ 3' 11 15/16"	0.195	Passed (L/999+)	--	1.0 D + 0.75 L + 0.75 S (Alt Spans) [1]
Total Load Defl. (in)	0.104 @ 3' 10 1/4"	0.390	Passed (L/897)	--	1.0 D + 0.75 L + 0.75 S (Alt Spans) [1]

Member Length : 10' 3 1/2"
 System : Floor
 Member Type : Flush Beam
 Building Use : Residential
 Building Code : IBC 2018
 Design Methodology : ASD

- Deflection criteria: LL (L/480) and TL (L/240).
- Overhang deflection criteria: LL (2L/480) and TL (2L/240).
- Allowed moment does not reflect the adjustment for the beam stability factor.

Supports	Bearing Length			Loads to Supports (lbs)				Accessories
	Total	Available	Required	Dead	Floor Live	Snow	Factored	
1 - Stud wall - HF	3.50"	3.50"	3.42"	1969	1946/-117	1899	4853	Blocking
2 - Stud wall - HF	6.00"	6.00"	5.89"	4289	1637	3778	8350	Blocking

• Blocking Panels are assumed to carry no loads applied directly above them and the full load is applied to the member being designed.

Lateral Bracing	Bracing Intervals	Comments
Top Edge (Lu)	10' 4" o/c	
Bottom Edge (Lu)	10' 4" o/c	

•Maximum allowable bracing intervals based on applied load.

Vertical Loads	Location (Side)	Tributary Width	Dead (0.90)	Floor Live (1.00)	Snow (1.15)	Comments
0 - Self Weight (PLF)	0 to 10' 3 1/2"	N/A	13.0	--	--	
1 - Point (lb)	10' 1 1/4" (Front)	N/A	886	146	409	Linked from: UB-07, Support 2
2 - Uniform (PLF)	0 to 10' 3" (Front)	N/A	467.3	220.5	495.0	Linked from: UJ-05, Support 2
3 - Point (lb)	1 3/4" (Front)	N/A	430	1050	31/-37	Linked from: UB-09, Support 2

• Side loads are assumed to not induce cross-grain tension.

Weyerhaeuser Notes

Weyerhaeuser warrants that the sizing of its products will be in accordance with Weyerhaeuser product design criteria and published design values. Weyerhaeuser expressly disclaims any other warranties related to the software. Use of this software is not intended to circumvent the need for a design professional as determined by the authority having jurisdiction. The designer of record, builder or framer is responsible to assure that this calculation is compatible with the overall project. Accessories (Rim Board, Blocking Panels and Squash Blocks) are not designed by this software. Products manufactured at Weyerhaeuser facilities are third-party certified to sustainable forestry standards. Weyerhaeuser Engineered Lumber Products have been evaluated by ICC-ES under evaluation reports ESR-1153 and ESR-1387 and/or tested in accordance with applicable ASTM standards. For current code evaluation reports, Weyerhaeuser product literature and installation details refer to www.weyerhaeuser.com/woodproducts/document-library.

The product application, input design loads, dimensions and support information have been provided by ForteWEB Software Operator

ForteWEB Software Operator	Job Notes
Mariam Soliman BTL Engineering PS (425) 814-8448 mariam.soliman@btleng.net	



9/29/2024 5:41:52 PM UTC
 ForteWEB v3.8, Engine: V8.4.1.24, Data: V8.1.6.3
 File Name: Dann Residence

Upper Floor/ Main Wall, UB-19

1 piece(s) 5 1/2" x 18" 24F-V4 DF Glulam

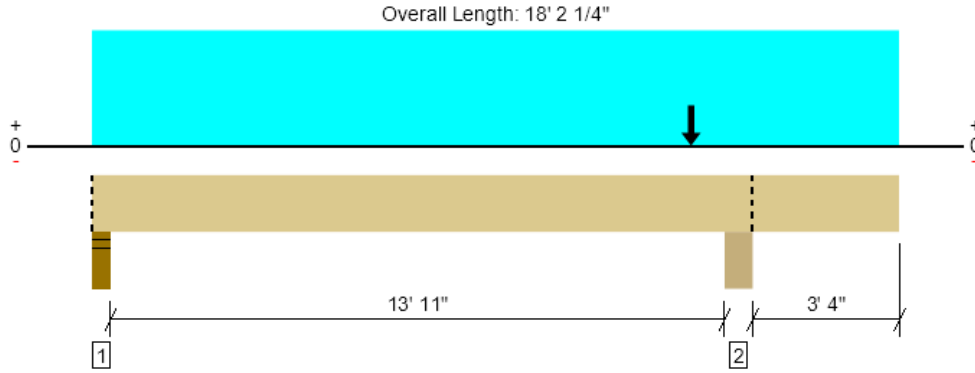

Drawing is Conceptual. All locations are measured from the outside face of left support (or left cantilever end). All dimensions are horizontal (typ.).

Design Results	Actual @ Location	Allowed	Result	LDF	Load: Combination (Pattern)
Member Reaction (lbs)	6369 @ 3"	10024 (4.50")	Passed (64%)	--	1.0 D + 1.0 L (Alt Spans)
Shear (lbs)	6674 @ 12' 9 1/2"	17490	Passed (38%)	1.00	1.0 D + 1.0 L (All Spans)
Pos Moment (Ft-lbs)	22616 @ 7' 7 1/8"	58923	Passed (38%)	1.00	1.0 D + 1.0 L (Alt Spans)
Neg Moment (Ft-lbs)	-5479 @ 14' 6 7/8"	45788	Passed (12%)	1.00	1.0 D + 1.0 L (All Spans)
Live Load Defl. (in)	0.120 @ 7' 5 5/8"	0.358	Passed (L/999+)	--	1.0 D + 1.0 L (Alt Spans)
Total Load Defl. (in)	0.175 @ 7' 5 5/8"	0.716	Passed (L/982)	--	1.0 D + 1.0 L (Alt Spans)

Member Length : 18' 2 1/4"
 System : Floor
 Member Type : Flush Beam
 Building Use : Residential
 Building Code : IBC 2018
 Design Methodology : ASD

- Deflection criteria: LL (L/480) and TL (L/240).
- Overhang deflection criteria: LL (2L/480) and TL (2L/240).
- Allowed moment does not reflect the adjustment for the beam stability factor.
- Critical positive moment adjusted by a volume/size factor of 0.99 that was calculated using length L = 14' 1 11/16".
- Critical negative moment adjusted by a volume/size factor of 1.00 that was calculated using length L = 4' 2 1/4".
- The effects of positive or negative camber have not been accounted for when calculating deflection.
- The specified glulam is assumed to have its strong laminations at the bottom of the beam. Install with proper side up as indicated by the manufacturer.
- Applicable calculations are based on NDS.

Supports	Bearing Length			Loads to Supports (lbs)				Accessories
	Total	Available	Required	Dead	Floor Live	Snow	Factored	
1 - Stud wall - HF	4.50"	4.50"	2.86"	2003	4366/-262	131	6369	Blocking
2 - Beam - GLB	6.75"	6.75"	3.58"	5046	7745	1616	12791	Blocking

• Blocking Panels are assumed to carry no loads applied directly above them and the full load is applied to the member being designed.

Lateral Bracing	Bracing Intervals	Comments
Top Edge (Lu)	18' 2" o/c	
Bottom Edge (Lu)	18' 2" o/c	

•Maximum allowable bracing intervals based on applied load.

Vertical Loads	Location (Side)	Tributary Width	Dead (0.90)	Floor Live (1.00)	Snow (1.15)	Comments
0 - Self Weight (PLF)	0 to 18' 2 1/4"	N/A	24.1	--	--	
1 - Uniform (PSF)	0 to 18' 2 1/4" (Front)	9' 7"	25.0	60.0	-	Deck
2 - Point (lb)	13' 6" (Front)	N/A	2253	1390	1747	Linked from: UB-05, Support 1

• Side loads are assumed to not induce cross-grain tension.

Weyerhaeuser Notes

Weyerhaeuser warrants that the sizing of its products will be in accordance with Weyerhaeuser product design criteria and published design values. Weyerhaeuser expressly disclaims any other warranties related to the software. Use of this software is not intended to circumvent the need for a design professional as determined by the authority having jurisdiction. The designer of record, builder or framer is responsible to assure that this calculation is compatible with the overall project. Accessories (Rim Board, Blocking Panels and Squash Blocks) are not designed by this software. Products manufactured at Weyerhaeuser facilities are third-party certified to sustainable forestry standards. Weyerhaeuser Engineered Lumber Products have been evaluated by ICC-ES under evaluation reports ESR-1153 and ESR-1387 and/or tested in accordance with applicable ASTM standards. For current code evaluation reports, Weyerhaeuser product literature and installation details refer to www.weyerhaeuser.com/woodproducts/document-library.

The product application, input design loads, dimensions and support information have been provided by ForteWEB Software Operator

ForteWEB Software Operator	Job Notes
Mariam Soliman BTL Engineering PS (425) 814-8448 mariam.soliman@btleng.net	



9/29/2024 5:41:52 PM UTC
 ForteWEB v3.8, Engine: V8.4.1.24, Data: V8.1.6.3
 File Name: Dann Residence

Upper Floor/ Main Wall, UB-20

1 piece(s) 3 1/2" x 9 1/2" 1.55E TimberStrand® LSL

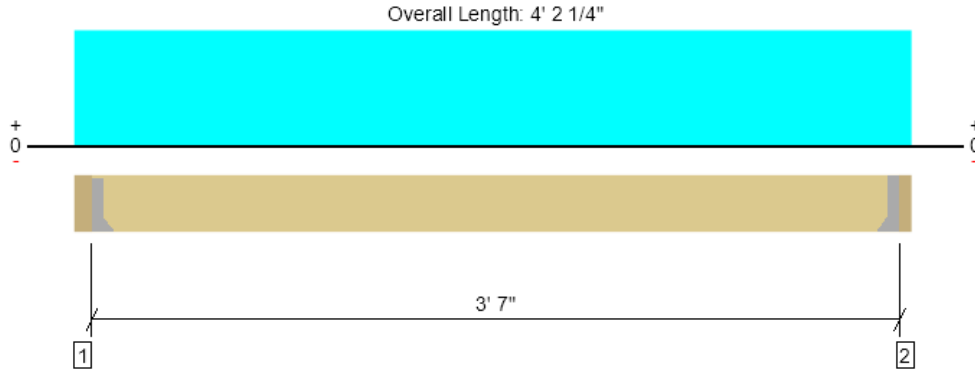

Drawing is Conceptual. All locations are measured from the outside face of left support (or left cantilever end). All dimensions are horizontal (typ.).

Design Results	Actual @ Location	Allowed	Result	LDF	Load: Combination (Pattern)
Member Reaction (lbs)	1478 @ 4 1/4"	4725 (1.50")	Passed (31%)	--	1.0 D + 1.0 L (All Spans)
Shear (lbs)	825 @ 1' 1 3/4"	6872	Passed (12%)	1.00	1.0 D + 1.0 L (All Spans)
Moment (Ft-lbs)	1324 @ 2' 1 3/4"	10422	Passed (13%)	1.00	1.0 D + 1.0 L (All Spans)
Live Load Defl. (in)	0.010 @ 2' 1 3/4"	0.090	Passed (L/999+)	--	1.0 D + 1.0 L (All Spans)
Total Load Defl. (in)	0.014 @ 2' 1 3/4"	0.179	Passed (L/999+)	--	1.0 D + 1.0 L (All Spans)

Member Length : 3' 7"
 System : Floor
 Member Type : Flush Beam
 Building Use : Residential
 Building Code : IBC 2018
 Design Methodology : ASD

- Deflection criteria: LL (L/480) and TL (L/240).
- Allowed moment does not reflect the adjustment for the beam stability factor.

Supports	Bearing Length			Loads to Supports (lbs)			Accessories
	Total	Available	Required	Dead	Floor Live	Factored	
1 - Hanger on 9 1/2" LSL beam	4.25"	Hanger ¹	1.50"	533	1234	1767	See note ¹
2 - Hanger on 9 1/2" PSL beam	3.00"	Hanger ¹	1.50"	508	1174	1682	See note ¹

- At hanger supports, the Total Bearing dimension is equal to the width of the material that is supporting the hanger
- ¹ See Connector grid below for additional information and/or requirements.

Lateral Bracing	Bracing Intervals	Comments
Top Edge (Lu)	3' 7" o/c	
Bottom Edge (Lu)	3' 7" o/c	

- Maximum allowable bracing intervals based on applied load.

Connector: Simpson Strong-Tie							
Support	Model	Seat Length	Top Fasteners	Face Fasteners	Member Fasteners	Accessories	
1 - Face Mount Hanger	LUS410	2.00"	N/A	8-10d	6-10d		
2 - Face Mount Hanger	LUS410	2.00"	N/A	8-10d	6-10d		

- Refer to manufacturer notes and instructions for proper installation and use of all connectors.

Vertical Loads	Location (Side)	Tributary Width	Dead (0.90)	Floor Live (1.00)	Comments
0 - Self Weight (PLF)	4 1/4" to 3' 11 1/4"	N/A	10.4	--	
1 - Uniform (PSF)	0 to 4' 2 1/4" (Front)	9' 7"	25.0	60.0	Deck

- Side loads are assumed to not induce cross-grain tension.

Weyerhaeuser Notes
<p>Weyerhaeuser warrants that the sizing of its products will be in accordance with Weyerhaeuser product design criteria and published design values. Weyerhaeuser expressly disclaims any other warranties related to the software. Use of this software is not intended to circumvent the need for a design professional as determined by the authority having jurisdiction. The designer of record, builder or framer is responsible to assure that this calculation is compatible with the overall project. Accessories (Rim Board, Blocking Panels and Squash Blocks) are not designed by this software. Products manufactured at Weyerhaeuser facilities are third-party certified to sustainable forestry standards. Weyerhaeuser Engineered Lumber Products have been evaluated by ICC-ES under evaluation reports ESR-1153 and ESR-1387 and/or tested in accordance with applicable ASTM standards. For current code evaluation reports, Weyerhaeuser product literature and installation details refer to www.weyerhaeuser.com/woodproducts/document-library.</p> <p>The product application, input design loads, dimensions and support information have been provided by ForteWEB Software Operator</p>

ForteWEB Software Operator	Job Notes
Mariam Soliman BTL Engineering PS (425) 814-8448 mariam.soliman@btleng.net	



9/29/2024 5:41:52 PM UTC
 ForteWEB v3.8, Engine: V8.4.1.24, Data: V8.1.6.3
 File Name: Dann Residence

Upper Floor/ Main Wall, UB-21

1 piece(s) 3 1/2" x 11 7/8" 1.55E TimberStrand® LSL

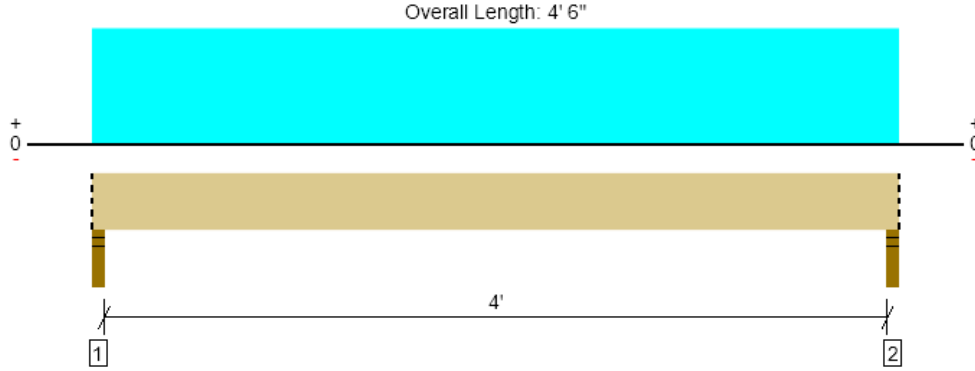

Drawing is Conceptual. All locations are measured from the outside face of left support (or left cantilever end). All dimensions are horizontal (typ.).

Design Results	Actual @ Location	Allowed	Result	LDF	Load: Combination (Pattern)
Member Reaction (lbs)	1081 @ 1 1/2"	4253 (3.00")	Passed (25%)	--	1.0 D + 1.0 L (All Spans)
Shear (lbs)	485 @ 1' 2 7/8"	8590	Passed (6%)	1.00	1.0 D + 1.0 L (All Spans)
Moment (Ft-lbs)	1085 @ 2' 3"	15953	Passed (7%)	1.00	1.0 D + 1.0 L (All Spans)
Live Load Defl. (in)	0.006 @ 2' 3"	0.106	Passed (L/999+)	--	1.0 D + 1.0 L (All Spans)
Total Load Defl. (in)	0.009 @ 2' 3"	0.213	Passed (L/999+)	--	1.0 D + 1.0 L (All Spans)

Member Length : 4' 6"
 System : Floor
 Member Type : Flush Beam
 Building Use : Residential
 Building Code : IBC 2018
 Design Methodology : ASD

- Deflection criteria: LL (L/480) and TL (L/240).
- Allowed moment does not reflect the adjustment for the beam stability factor.

Supports	Bearing Length			Loads to Supports (lbs)			Accessories
	Total	Available	Required	Dead	Floor Live	Factored	
1 - Stud wall - HF	3.00"	3.00"	1.50"	316	765	1081	Blocking
2 - Stud wall - HF	3.00"	3.00"	1.50"	316	765	1081	Blocking

- Blocking Panels are assumed to carry no loads applied directly above them and the full load is applied to the member being designed.

Lateral Bracing	Bracing Intervals	Comments
Top Edge (Lu)	4' 6" o/c	
Bottom Edge (Lu)	4' 6" o/c	

- Maximum allowable bracing intervals based on applied load.

Vertical Loads	Location (Side)	Tributary Width	Dead (0.90)	Floor Live (1.00)	Comments
0 - Self Weight (PLF)	0 to 4' 6"	N/A	13.0	--	
1 - Uniform (PSF)	0 to 4' 6" (Front)	8' 6"	15.0	40.0	Upper Floor

- Side loads are assumed to not induce cross-grain tension.

Weyerhaeuser Notes

Weyerhaeuser warrants that the sizing of its products will be in accordance with Weyerhaeuser product design criteria and published design values. Weyerhaeuser expressly disclaims any other warranties related to the software. Use of this software is not intended to circumvent the need for a design professional as determined by the authority having jurisdiction. The designer of record, builder or framer is responsible to assure that this calculation is compatible with the overall project. Accessories (Rim Board, Blocking Panels and Squash Blocks) are not designed by this software. Products manufactured at Weyerhaeuser facilities are third-party certified to sustainable forestry standards. Weyerhaeuser Engineered Lumber Products have been evaluated by ICC-ES under evaluation reports ESR-1153 and ESR-1387 and/or tested in accordance with applicable ASTM standards. For current code evaluation reports, Weyerhaeuser product literature and installation details refer to www.weyerhaeuser.com/woodproducts/document-library.

The product application, input design loads, dimensions and support information have been provided by ForteWEB Software Operator

ForteWEB Software Operator	Job Notes
Mariam Soliman BTL Engineering PS (425) 814-8448 mariam.soliman@btleng.net	



9/29/2024 5:41:52 PM UTC
 ForteWEB v3.8, Engine: V8.4.1.24, Data: V8.1.6.3
 File Name: Dann Residence

BTL

ENGINEERING

19011 Wood-Sno Road NE, Suite 100

Woodinville, WA 98072-4436

Phone: (425) 814-8448

Fax: (425) 821-2120

Gravity

Main Floor Framing

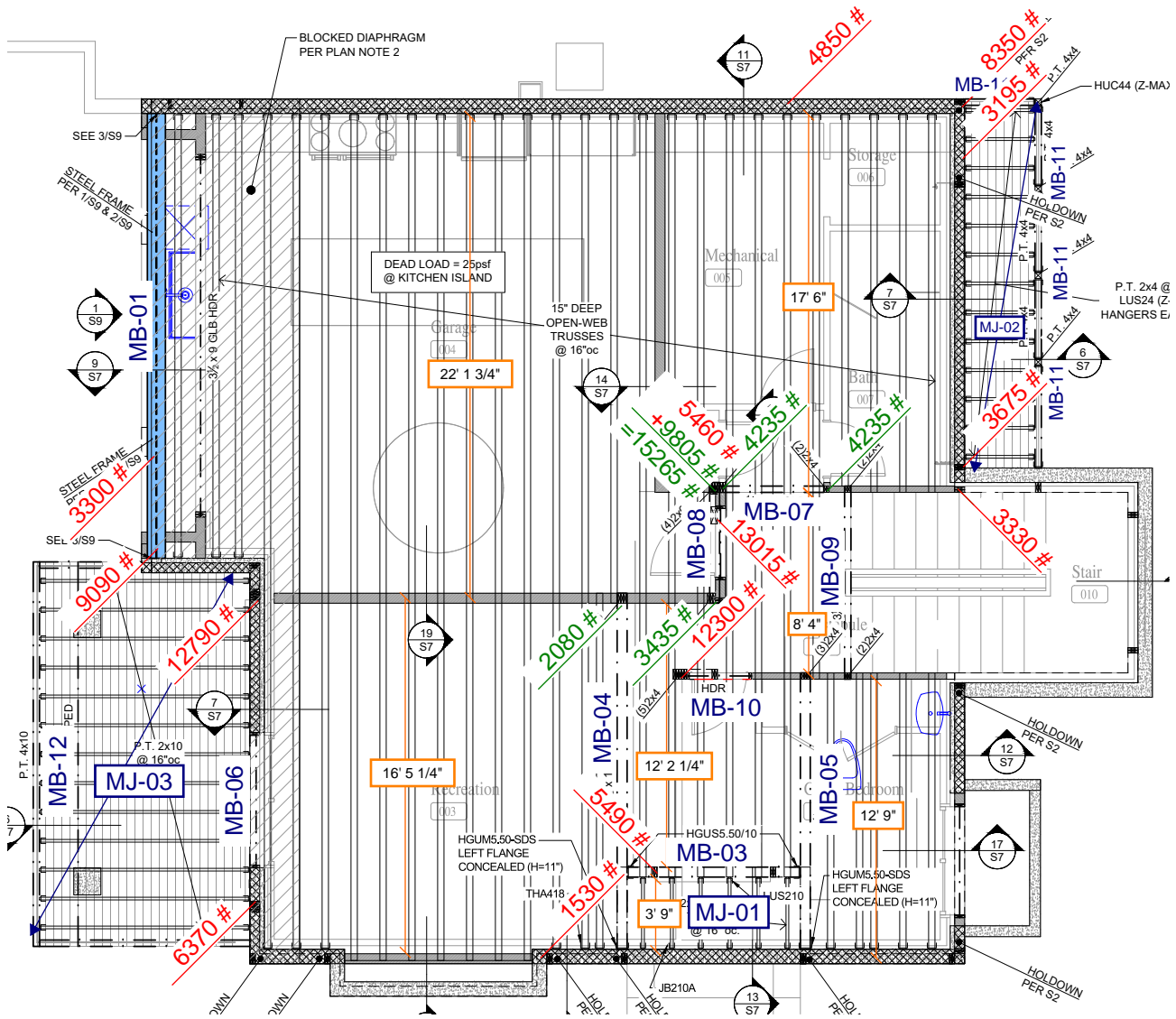

Main Floor Framing Key Plan

Main Floor/Lower Wall, MJ-01
1 piece(s) 2 x 10 HF No.2 @ 16" OC

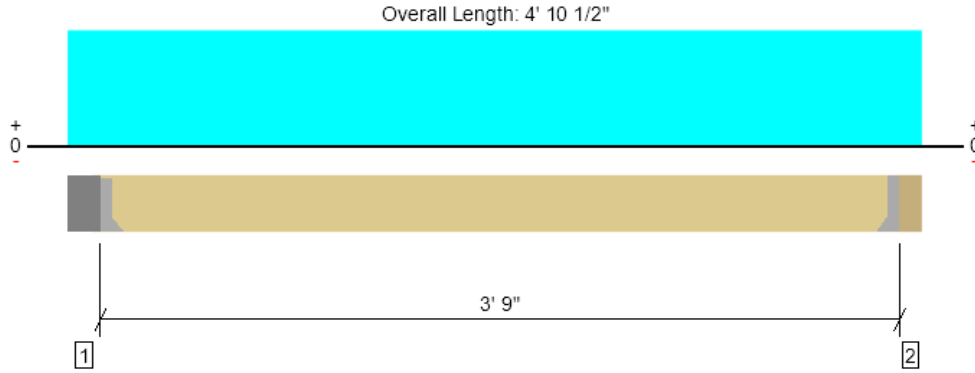

Drawing is Conceptual. All locations are measured from the outside face of left support (or left cantilever end). All dimensions are horizontal (typ.).

Design Results	Actual @ Location	Allowed	Result	LDF	Load: Combination (Pattern)
Member Reaction (lbs)	225 @ 8"	911 (1.50")	Passed (25%)	--	1.0 D + 1.0 Lr (All Spans)
Shear (lbs)	133 @ 1' 5 1/4"	1734	Passed (8%)	1.25	1.0 D + 1.0 Lr (All Spans)
Moment (Ft-lbs)	211 @ 2' 6 1/2"	2396	Passed (9%)	1.25	1.0 D + 1.0 Lr (All Spans)
Live Load Defl. (in)	0.002 @ 2' 6 1/2"	0.094	Passed (L/999+)	--	1.0 D + 1.0 Lr (All Spans)
Total Load Defl. (in)	0.004 @ 2' 6 1/2"	0.188	Passed (L/999+)	--	1.0 D + 1.0 Lr (All Spans)
TJ-Pro™ Rating	N/A	N/A	N/A	--	N/A

Member Length : 3' 9"
 System : Floor
 Member Type : Joist
 Building Use : Residential
 Building Code : IBC 2018
 Design Methodology : ASD

- Deflection criteria: LL (L/480) and TL (L/240).
- Allowed moment does not reflect the adjustment for the beam stability factor.
- A 15% increase in the moment capacity has been added to account for repetitive member usage.
- Applicable calculations are based on NDS.
- No composite action between deck and joist was considered in analysis.

Supports	Bearing Length			Loads to Supports (lbs)			Accessories
	Total	Available	Required	Dead	Roof Live	Factored	
1 - Hanger on concrete	8.00"	Hanger ¹	1.50"	169	136	305	See note ¹
2 - Hanger on 9 1/4" GLB beam	5.50"	Hanger ¹	1.50"	156	124	280	See note ¹

- At hanger supports, the Total Bearing dimension is equal to the width of the material that is supporting the hanger
- ¹ See Connector grid below for additional information and/or requirements.

Lateral Bracing	Bracing Intervals	Comments
Top Edge (Lu)	3' 9" o/c	
Bottom Edge (Lu)	3' 9" o/c	

•Maximum allowable bracing intervals based on applied load.

Connector: Simpson Strong-Tie							
Support	Model	Seat Length	Top Fasteners	Face Fasteners	Member Fasteners	Accessories	
1 - Face Mount Hanger	HU210	2.25"	N/A	8-TNT25214H	4-10dx1.5		
2 - Face Mount Hanger	LU28	1.50"	N/A	8-10dx1.5	6-10dx1.5		

- Refer to manufacturer notes and instructions for proper installation and use of all connectors.

Vertical Load	Location (Side)	Spacing	Dead (0.90)	Roof Live (1.25)	Comments
1 - Uniform (PSF)	0 to 4' 10 1/2"	16"	50.0	40.0	Main Floor

Member Notes
(converted from: Roof Joist)

ForteWEB Software Operator	Job Notes
Mariam Soliman BTL Engineering PS (425) 814-8448 mariam.soliman@btleng.net	



9/24/2024 5:45:01 PM UTC
 ForteWEB v3.8, Engine: V8.4.1.24, Data: V8.1.6.3
 File Name: Dann Residence

Main Floor/Lower Wall, MJ-02
1 piece(s) 2 x 4 HF No.2 @ 16" OC

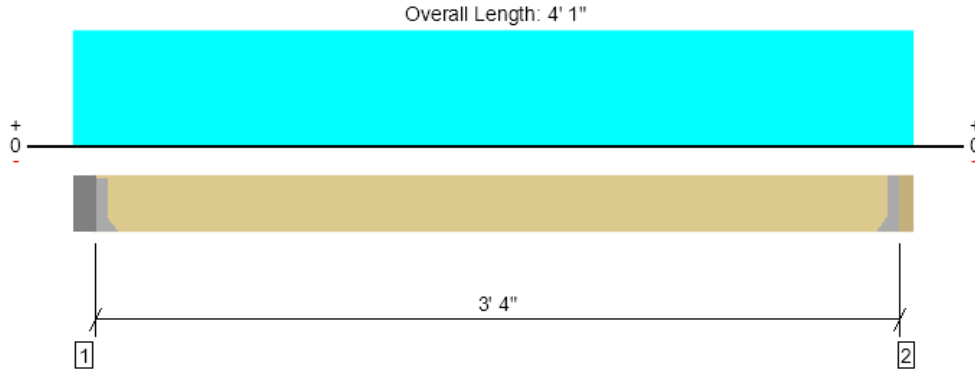

Drawing is Conceptual. All locations are measured from the outside face of left support (or left cantilever end). All dimensions are horizontal (typ.).

Design Results	Actual @ Location	Allowed	Result	LDF	Load: Combination (Pattern)
Member Reaction (lbs)	167 @ 5 1/2"	911 (1.50")	Passed (18%)	--	1.0 D + 1.0 Lr (All Spans)
Shear (lbs)	137 @ 9"	656	Passed (21%)	1.25	1.0 D + 1.0 Lr (All Spans)
Moment (Ft-lbs)	139 @ 2' 1 1/2"	468	Passed (30%)	1.25	1.0 D + 1.0 Lr (All Spans)
Live Load Defl. (in)	0.032 @ 2' 1 1/2"	0.083	Passed (L/999+)	--	1.0 D + 1.0 Lr (All Spans)
Total Load Defl. (in)	0.040 @ 2' 1 1/2"	0.167	Passed (L/999+)	--	1.0 D + 1.0 Lr (All Spans)
TJ-Pro™ Rating	N/A	N/A	N/A	--	N/A

Member Length : 3' 4"
 System : Floor
 Member Type : Joist
 Building Use : Residential
 Building Code : IBC 2018
 Design Methodology : ASD

- Deflection criteria: LL (L/480) and TL (L/240).
- Allowed moment does not reflect the adjustment for the beam stability factor.
- A 15% increase in the moment capacity has been added to account for repetitive member usage.
- Applicable calculations are based on NDS.
- No composite action between deck and joist was considered in analysis.

Supports	Bearing Length			Loads to Supports (lbs)			Accessories
	Total	Available	Required	Dead	Roof Live	Factored	
1 - Hanger on concrete	5.50"	Hanger ¹	1.50"	43	170	212	See note ¹
2 - Hanger on 3 1/2" DF beam	3.50"	Hanger ¹	1.50"	39	157	196	See note ¹

- At hanger supports, the Total Bearing dimension is equal to the width of the material that is supporting the hanger
- ¹ See Connector grid below for additional information and/or requirements.

Lateral Bracing	Bracing Intervals	Comments
Top Edge (Lu)	3' 4" o/c	
Bottom Edge (Lu)	3' 4" o/c	

•Maximum allowable bracing intervals based on applied load.

Connector: Simpson Strong-Tie							
Support	Model	Seat Length	Top Fasteners	Face Fasteners	Member Fasteners	Accessories	
1 - Face Mount Hanger	Connector not found	N/A	N/A	N/A	N/A		
2 - Face Mount Hanger	LU24	1.50"	N/A	4-10dx1.5	2-10dx1.5		

- Refer to manufacturer notes and instructions for proper installation and use of all connectors.

Vertical Load	Location (Side)	Spacing	Dead (0.90)	Roof Live (1.25)	Comments
1 - Uniform (PSF)	0 to 4' 1"	16"	15.0	60.0	Main Floor-Deck

Member Notes
(converted from: Roof Joist)

ForteWEB Software Operator	Job Notes
Mariam Soliman BTL Engineering PS (425) 814-8448 mariam.soliman@btleng.net	



9/24/2024 5:28:43 PM UTC
 ForteWEB v3.8, Engine: V8.4.1.24, Data: V8.1.6.3
 File Name: Dann Residence

Main Floor/Lower Wall, MJ-03
1 piece(s) 2 x 10 HF No.2 @ 16" OC

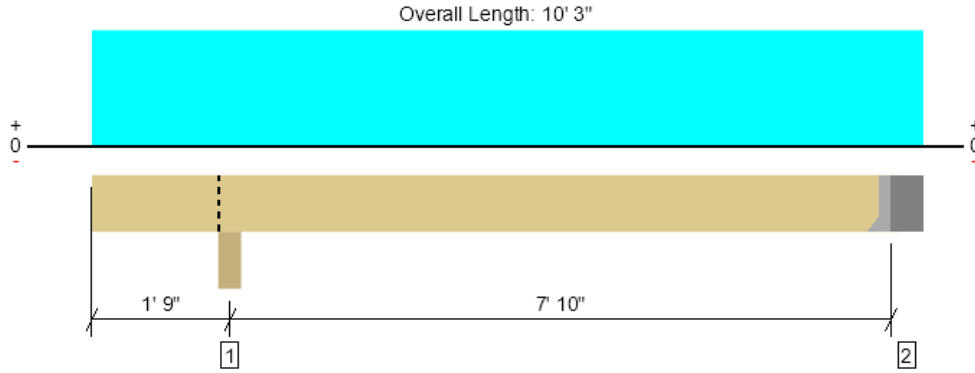

Drawing is Conceptual. All locations are measured from the outside face of left support (or left cantilever end). All dimensions are horizontal (typ.).

Design Results	Actual @ Location	Allowed	Result	LDF	Load: Combination (Pattern)
Member Reaction (lbs)	380 @ 9' 7"	911 (1.50")	Passed (42%)	--	1.0 D + 1.0 Lr (Alt Spans)
Shear (lbs)	311 @ 2' 9"	1734	Passed (18%)	1.25	1.0 D + 1.0 Lr (All Spans)
Moment (Ft-lbs)	722 @ 5' 9 7/16"	2396	Passed (30%)	1.25	1.0 D + 1.0 Lr (Alt Spans)
Live Load Defl. (in)	0.050 @ 5' 8 3/8"	0.196	Passed (L/999+)	--	1.0 D + 1.0 Lr (Alt Spans)
Total Load Defl. (in)	0.061 @ 5' 8 7/16"	0.392	Passed (L/999+)	--	1.0 D + 1.0 Lr (Alt Spans)
TJ-Pro™ Rating	N/A	N/A	N/A	--	N/A

Member Length : 9' 7"
 System : Floor
 Member Type : Joist
 Building Use : Residential
 Building Code : IBC 2018
 Design Methodology : ASD

- Deflection criteria: LL (L/480) and TL (L/240).
- Overhang deflection criteria: LL (2L/480) and TL (2L/240).
- Allowed moment does not reflect the adjustment for the beam stability factor.
- A 15% increase in the moment capacity has been added to account for repetitive member usage.
- Applicable calculations are based on NDS.
- No composite action between deck and joist was considered in analysis.

Supports	Bearing Length			Loads to Supports (lbs)			Accessories
	Total	Available	Required	Dead	Roof Live	Factored	
1 - Beam - DF	5.50"	5.50"	1.50"	117	469	586	Blocking
2 - Hanger on concrete	8.00"	Hanger ¹	1.50"	88	359	447	See note ¹

- Blocking Panels are assumed to carry no loads applied directly above them and the full load is applied to the member being designed.
- At hanger supports, the Total Bearing dimension is equal to the width of the material that is supporting the hanger
- ¹ See Connector grid below for additional information and/or requirements.

Lateral Bracing	Bracing Intervals	Comments
Top Edge (Lu)	9' 7" o/c	
Bottom Edge (Lu)	9' 7" o/c	

•Maximum allowable bracing intervals based on applied load.

Connector: Simpson Strong-Tie

Support	Model	Seat Length	Top Fasteners	Face Fasteners	Member Fasteners	Accessories
2 - Face Mount Hanger	HU210	2.25"	N/A	8-TNT25214H	4-10dx1.5	

• Refer to manufacturer notes and instructions for proper installation and use of all connectors.

Vertical Load	Location (Side)	Spacing	Dead (0.90)	Roof Live (1.25)	Comments
1 - Uniform (PSF)	0 to 10' 3"	16"	15.0	60.0	Main Floor-Deck

Member Notes

(converted from: Roof Joist)

ForteWEB Software Operator	Job Notes
Mariam Soliman BTL Engineering PS (425) 814-8448 mariam.soliman@btleng.net	



9/29/2024 4:48:32 PM UTC
 ForteWEB v3.8, Engine: V8.4.1.24, Data: V8.1.6.3
 File Name: Dann Residence

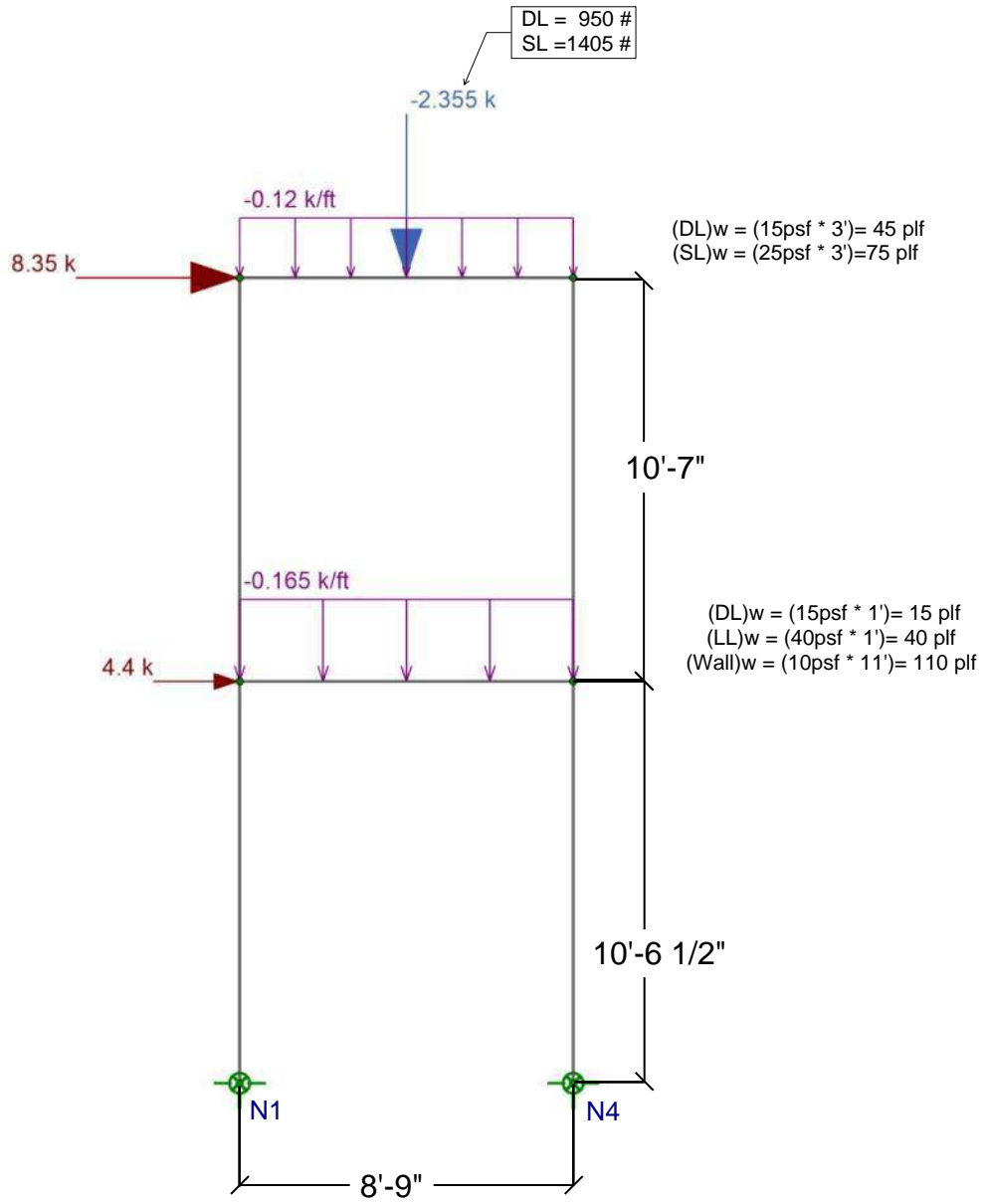
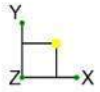

Loads: LC 5, Unfactored

BTL Engineering
 Mariam Soliman

Dann Residence Moment Frame

SK-1

May 29, 2024

Dann Moment Frame MS SW1.r3d

Node Reactions		DL Only						
LC	Node Label	X [k]	Y [k]	Z [k]	MX [k-ft]	MY [k-ft]	MZ [k-ft]	
1	1	N1	0.03	2.049	0	0	0	-0.106
2	1	N4	-0.03	2.049	0	0	0	0.106
3	1	Totals:	0	4.099	0			
4	1	COG (ft):	X: 4.375	Y: 14.645	Z: 0			

Node Reactions		SL Only						
LC	Node Label	X [k]	Y [k]	Z [k]	MX [k-ft]	MY [k-ft]	MZ [k-ft]	
1	2	N1	-0.034	1.031	0	0	0	0.117
2	2	N4	0.034	1.031	0	0	0	-0.117
3	2	Totals:	0	2.061	0			
4	2	COG (ft):	X: 4.375	Y: 21.125	Z: 0			

Node Reactions		LL Only						
LC	Node Label	X [k]	Y [k]	Z [k]	MX [k-ft]	MY [k-ft]	MZ [k-ft]	
1	3	N1	0.015	0.175	0	0	0	-0.051
2	3	N4	-0.015	0.175	0	0	0	0.051
3	3	Totals:	0	0.35	0			
4	3	COG (ft):	X: 4.375	Y: 10.54	Z: 0			

Node Reactions		EQ Only						
LC	Node Label	X [k]	Y [k]	Z [k]	MX [k-ft]	MY [k-ft]	MZ [k-ft]	
1	4	N1	-6.53	-16.194	0	0	0	40.574
2	4	N4	-6.22	16.194	0	0	0	40.517
3	4	Totals:	-12.75	0	0			
4	4	COG (ft):	NC	NC	NC			

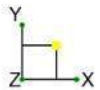

Roof(DL)-w = (15psf * 3')= 45 plf
 (Wall)w = (10psf * 11')= 110 plf
 Upper Floor-(DL)w = (15psf * 1')= 15 plf
 (Wall)w = (10psf * 9.5')= 95 plf
 Main Floor-(DL)w = (15psf * 1')= 15 plf
 Total =280-plf

UB-16

Moment
Frame

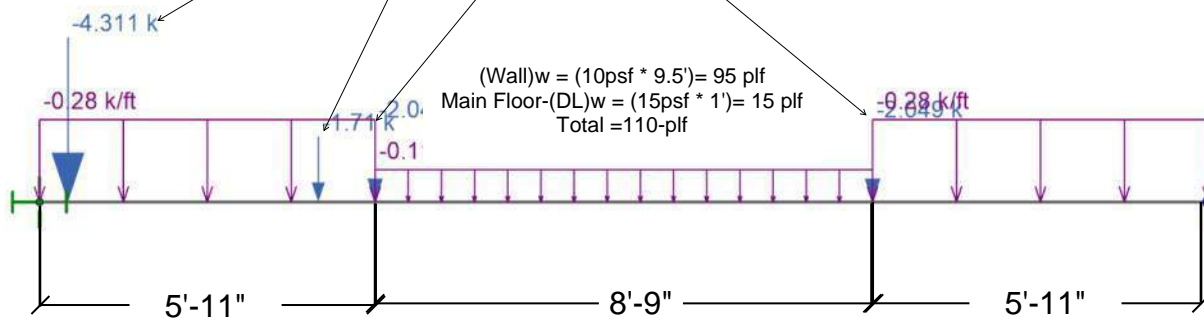

Loads: BLC 1, DL

BTL Engineering
 Mariam Soliman

Dann Residence Beam Design MB-01

SK-2

Oct 01, 2024

Dann MB-01 Design.r3d

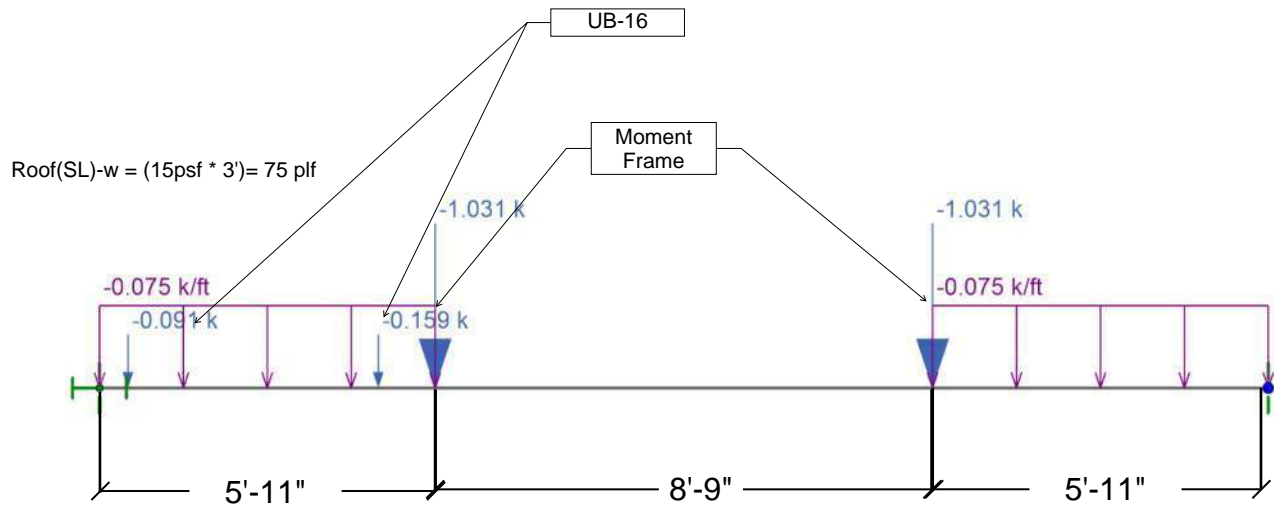
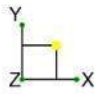

Loads: BLC 2, SL

BTL Engineering
Mariam Soliman

Dann Residence Beam Design MB-01

SK-3
Oct 01, 2024
Dann MB-01 Design.r3d

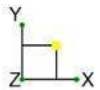

Upper Floor-(LL) $w = (40\text{psf} * 1') = 40\text{ plf}$
 Main Floor-(LL) $w = (15\text{psf} * 1') = 40\text{ plf}$
 Total = 40-plf

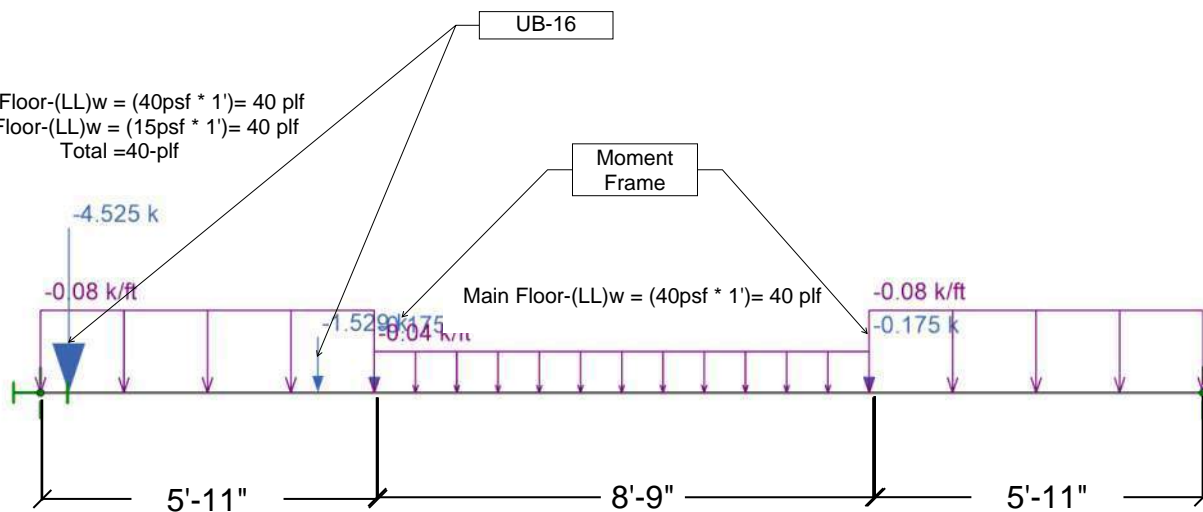

Loads: BLC 4, LL

BTL Engineering
 Mariam Soliman

Dann Residence Beam Design MB-01

SK-3
 Oct 01, 2024
 Dann MB-01 Design.r3d

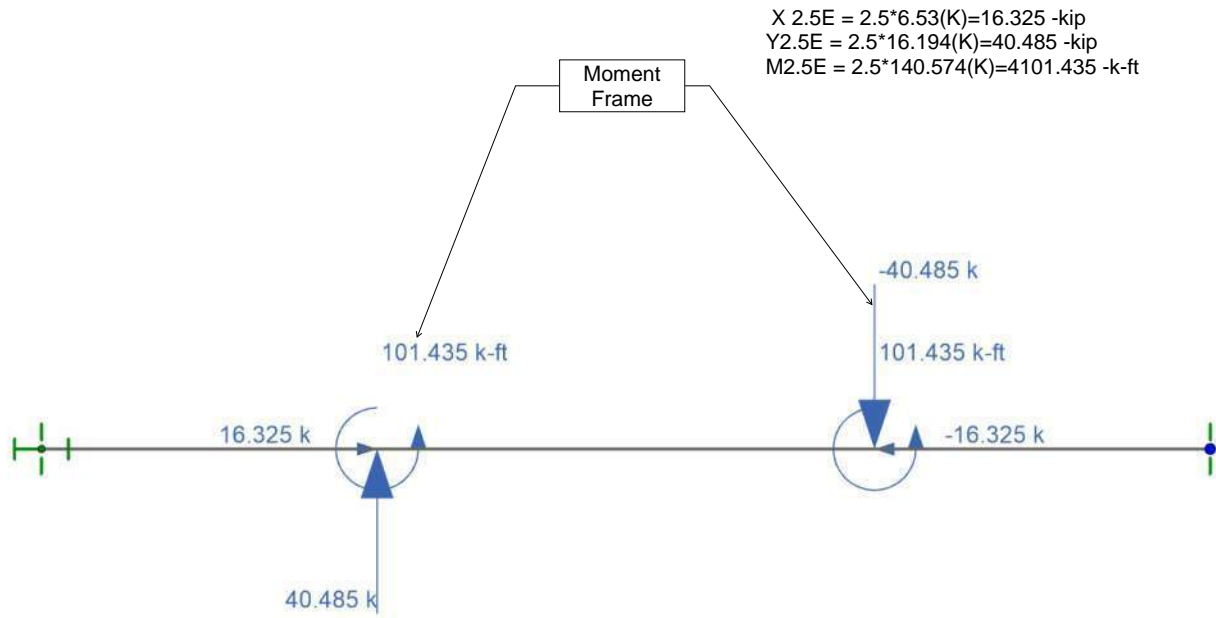
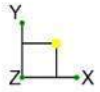

Loads: BLC 6, 2.5 E

BTL Engineering
Mariam Soliman

Dann Residence Beam Design MB-01

SK-4

Oct 01, 2024

Dann MB-01 Design.r3d

Node Reactions

DL Only

	LC	Node Label	X [k]	Y [k]	Z [k]	MX [k-ft]	MY [k-ft]	MZ [k-ft]
1	1	N1	0	5.175	0	NC	0	0
2	1	N2	0	4.638	NC	0	0	0
3	1	Totals:	0	9.395	0			
4	1	COG (ft):	X: 8.749	Y: 0	Z: 0			

Node Reactions

SL Only

	LC	Node Label	X [k]	Y [k]	Z [k]	MX [k-ft]	MY [k-ft]	MZ [k-ft]
1	2	N1	0	1.844	0	NC	0	0
2	2	N2	0	1.513	NC	0	0	0
3	2	Totals:	0	3.357	0			
4	2	COG (ft):	X: 8.17	Y: 0	Z: 0			

Node Reactions

LL Only

	LC	Node Label	X [k]	Y [k]	Z [k]	MX [k-ft]	MY [k-ft]	MZ [k-ft]
1	3	N1	0	0.849	0	NC	0	0
2	3	N2	0	0.76	NC	0	0	0
3	3	Totals:	0	1.609	0			
4	3	COG (ft):	X: 8.562	Y: 0	Z: 0			

Node Reactions

EQ Only

	LC	Node Label	X [k]	Y [k]	Z [k]	MX [k-ft]	MY [k-ft]	MZ [k-ft]
1	5	N1	-32.65	-8.352	0	NC	0	0
2	5	N2	0	8.352	NC	0	0	0
3	5	Totals:	-32.65	0	0			
4	5	COG (ft):	NC	NC	NC			

Node Coordinates

	Label	X [ft]	Y [ft]	Z [ft]	Detach From Diaphragm
1	N1	0	0	0	
2	N2	20.583	0	0	

Node Boundary Conditions

	Node Label	X [k/in]	Y [k/in]	Z [k/in]	X Rot [k-ft/rad]
1	N1	Reaction	Reaction	Reaction	Fixed
2	N2		Reaction	Fixed	

Member Primary Data

	Label	I Node	J Node	Section/Shape	Type	Design List	Material	Design Rule
1	M1	N1	N2	W12X58	Beam	Wide Flange	A992	Typical

LRFD

Envelope Node Reactions

	Node Label		X [k]	LC	Y [k]	LC	Z [k]	LC	MX [k-ft]	LC	MY [k-ft]	LC	MZ [k-ft]	LC
1	N1	max	0	26	22.72	22	0	27	NC	NC	0	27	0	27
2		min	0	25	1.351	26	0	20	NC	NC	0	20	0	20
3	N2	max	0	27	13.964	24	NC	NC	0	27	0	27	0	27
4		min	0	20	-3.145	27	NC	NC	0	20	0	20	0	20
5	Totals:	max	0	26	31.191	22	0	27						
6		min	0	25	12.954	26	0	20						

Envelope Node Displacements

	Node Label		X [in]	LC	Y [in]	LC	Z [in]	LC	X Rotation [rad]	LC	Y Rotation [rad]	LC	Z Rotation [rad]	LC
1	N1	max	0	27	0	26	0	27	0	27	0	27	-1.08e-4	26
2		min	0	24	0	22	0	20	0	20	0	20	-6.234e-3	25
3	N2	max	0.004	27	0	27	0	27	0	27	0	27	5.812e-3	24
4		min	-0.004	24	0	24	0	20	0	20	0	20	-1.213e-4	27

Bolt Grade A-325 Plate Grade A36
 Weld Electrode E70-xx

Check Bolt Group for Eccentricity

Beam Size	# of Bolts	Bolt Dia	Table 7-1	Table 7-1	Table 7-7	ASD	LRFD
			Available Shear	Available Shear	Eccentricity Coef. C	Bolt Group Shear Capacity $R_n/\Omega_v = C r_n/\Omega_v$	Bolt Group Shear Capacity $\phi_v R_n = \phi_v R_n$
W8, W10	2	3/4"	10.6	15.9	0.88	9.3	14.0
W12, W14	3	3/4"	10.6	15.9	1.75	18.6	27.8
W16	4	3/4"	10.6	15.9	2.81	29.8	44.7
W18	5	3/4"	10.6	15.9	3.90	41.3	62.0
W21	4	1"	18.8	28.3	2.81	52.8	79.5
W24	5	1"	18.8	28.3	3.90	73.3	110.4
W27	6	1"	18.8	28.3	4.98	93.6	140.9
W30	7	1"	18.8	28.3	6.06	113.9	171.5

Check Weld for Eccentricity

Beam Size	End Distance	Weld Length	Weld Thickness	Table 8-4	Table 8-3	ASD	LRFD
				Eccentricity Coef. C	Electrode Coef. C_1	Available Strength $R_n/\Omega_v = CC_1 D/2$	Available Strength $\phi R_n = 0.75 CC_1 D$
W8, W10	1 1/2"	6.0	3/16"	2.290	1.00	20.6	30.9
W12, W14	1 1/2"	9.0	3/16"	2.947	1.00	39.8	59.7
W16	1 1/2"	12.0	3/16"	3.310	1.00	59.6	89.4
W18	1 1/2"	15.0	3/16"	3.510	1.00	79.0	118.5
W21	1 3/4"	12.5	1/4"	3.510	1.00	87.8	131.6
W24	1 3/4"	15.5	1/4"	3.617	1.00	112.1	168.2
W27	1 3/4"	18.5	1/4"	3.670	1.00	135.8	203.7
W30	1 3/4"	21.5	1/4"	3.720	1.00	160.0	239.9

Check Plate for Shear Yielding, Shear Rupture

Beam Size	Plate			Shear Yielding	Shear Rupture	ASD	LRFD
	Thickness	A_g	A_{nv}	$R_n = 0.60 F_y A_g$	$R_n = 0.60 F_u A_{nv}$	$R_n/\Omega_v = R_n/2$	$\phi R_n = 0.75 R_n$
W8, W10	1/4"	1.50	1.09	32.4	38.1	16.2	24.3
W12, W14	1/4"	2.25	1.64	48.6	57.1	24.3	36.5
W16	1/4"	3.00	2.19	64.8	76.1	32.4	48.6
W18	1/4"	3.75	2.73	81.0	95.2	40.5	60.8
W21	3/8"	4.69	3.09	101.3	107.7	50.6	75.9
W24	3/8"	5.81	3.82	125.6	132.9	62.8	94.2
W27	3/8"	6.94	4.55	149.9	158.2	74.9	112.4
W30	3/8"	8.06	5.27	174.2	183.5	87.1	130.6

Check Plate for Shear Yielding, Shear Rupture

Beam Size	Plate			Block Shear	Block Shear	ASD	LRFD
	Thickness	A_{gv}	A_{nv}	$R_n = 0.60 F_u A_{nv} + U_{bs} F_u A_{nt}$	$R_n = 0.60 F_y A_{gv} + U_{bs} F_u A_{nt}$	$R_n/\Omega_v = R_n/2$	$\phi R_n = 0.75 R_n$
W8, W10	1/4"	1.13	0.82	44.4	40.2	20.1	30.1
W12, W14	1/4"	1.88	1.37	63.4	56.4	28.2	42.3
W16	1/4"	2.63	1.91	82.5	72.6	36.3	54.4
W18	1/4"	3.38	2.46	101.5	88.8	44.4	66.6
W21	3/8"	4.03	2.64	118.3	113.6	56.8	85.2
W24	3/8"	5.16	3.36	143.6	137.9	68.9	103.4
W27	3/8"	6.28	4.09	168.8	162.2	81.1	121.6
W30	3/8"	7.41	4.82	194.1	186.5	93.2	139.9

	ASD	LRFD
W8, W10	9.3	14.0
W12, W14	18.6	27.8
W16	29.8	44.7
W18	40.5	60.8
W21	50.6	75.9
W24	62.8	94.2
W27	74.9	112.4
W30	87.1	130.6

← Worst Case/ Lowest Values >22.72 (O.K.)

Table 10-9a (continued)
Single-Plate Connections
 Bolt, Weld, and Single-Plate Available Strengths, kips
 Plate $F_y = 36$ ksi
 3/4-in. diameter bolts

n	ASTM Desig.	Thread Cond.	Hole Type	Plate Thickness, in.											
				1/4		5/16		3/8		7/16		1/2		9/16	
				ASD	LRFD	ASD	LRFD	ASD	LRFD	ASD	LRFD	ASD	LRFD	ASD	LRFD
4 (L = 11 1/2)	A325	N	STD	34.8	52.2	42.4	63.6	42.4	63.6	42.4	63.6	—	—	—	—
			SSLT	34.7	52.0	42.4	63.6	42.4	63.6	—	—	—	—		
	F1852	X	STD	34.8	52.2	43.5	65.3	52.2	78.3	53.0	79.5	—	—	—	—
			SSLT	34.7	52.0	43.4	65.1	52.0	78.1	53.0	79.5	—	—	—	—
	A490	N	STD	34.8	52.2	43.5	65.3	52.2	78.3	53.0	79.5	—	—	—	—
			SSLT	34.7	52.0	43.4	65.1	52.0	78.1	53.0	79.5	—	—	—	—
		X	STD	34.8	52.2	43.5	65.3	52.2	78.3	60.9	91.4	—	—	—	—
			SSLT	34.7	52.0	43.4	65.1	52.0	78.1	60.7	91.1	—	—	—	—
3 (L = 8 1/2)	A325	N	STD	25.6	38.3	31.8	47.7	31.8	47.7	31.8	47.7	—	—	—	—
			SSLT	25.6	38.3	31.8	47.7	31.8	47.7	31.8	47.7	—	—	—	—
	F1852	X	STD	25.6	38.3	31.9	47.9	38.3	57.5	39.8	59.6	—	—	—	—
			SSLT	25.6	38.3	31.9	47.9	38.3	57.5	39.8	59.6	—	—	—	—
	A490	N	STD	25.6	38.3	31.9	47.9	38.3	57.5	39.8	59.6	—	—	—	—
			SSLT	25.6	38.3	31.9	47.9	38.3	57.5	39.8	59.6	—	—	—	—
		X	STD	25.6	38.3	31.9	47.9	38.3	57.5	44.7	67.1	—	—	—	—
			SSLT	25.6	38.3	31.9	47.9	38.3	57.5	44.7	67.1	—	—	—	—
2 (L = 5 1/2)	A325	N	STD	16.3	24.5	20.4	30.6	21.2	31.8	21.2	31.8	—	—	—	—
			SSLT	16.3	24.5	20.4	30.6	21.2	31.8	21.2	31.8	—	—	—	—
	F1852	X	STD	16.3	24.5	20.4	30.6	24.5	36.7	26.5	39.8	—	—	—	—
			SSLT	16.3	24.5	20.4	30.6	24.5	36.7	26.5	39.8	—	—	—	—
	A490	N	STD	16.3	24.5	20.4	30.6	24.5	36.7	26.5	39.8	—	—	—	—
			SSLT	16.3	24.5	20.4	30.6	24.5	36.7	26.5	39.8	—	—	—	—
		X	STD	16.3	24.5	20.4	30.6	24.5	36.7	28.5	42.8	—	—	—	—
			SSLT	16.3	24.5	20.4	30.6	24.5	36.7	28.5	42.8	—	—	—	—
Weld Size				3/16		1/4		1/4		5/16		5/16		3/8	
STD = Standard Holes SSLT = Short-slotted holes transverse to direction of load — indicates that the plate thickness is greater than $d_b/2 + 1/16$ in. Tabulated values are grouped when available strength is independent of hole type.												N = Threads Included X = Threads Excluded			



Company:		Date:	9/8/2022
Engineer:		Page:	1/5
Project:			
Address:			
Phone:			
E-mail:			

1. Project information

Project description:
Location:
Fastening description:

Comment:

2. Input Data & Anchor Parameters

General

Design method: ACI 318-19
Units: Imperial units

Anchor Information:

Anchor type: Concrete screw
Material: Carbon Steel
Diameter (inch): 0.625
Nominal Embedment depth (inch): 5.000
Effective Embedment depth, h_{ef} (inch): 3.820
Code report: ICC-ES ESR-2713
Anchor category: 1
Anchor ductility: No
 h_{min} (inch): 7.67
 c_{ac} (inch): 5.75
 C_{min} (inch): 1.75
 S_{min} (inch): 3.00

Base Material

Concrete: Normal-weight
Concrete thickness, h (inch): 8.00
State: Uncracked
Compressive strength, f'_c (psi): 3000
 $\Psi_{c,v}$: 1.4
Reinforcement condition: Supplementary reinforcement not present
Supplemental edge reinforcement: No
Reinforcement provided at corners: No
Ignore concrete breakout in tension: No
Ignore concrete breakout in shear: No
Ignore $6d_o$ requirement: Not applicable
Build-up grout pad: No

Base Plate

Length x Width x Thickness (inch): 9.00 x 20.00 x 0.25

Recommended Anchor

Anchor Name: **Titen HD® - 5/8"Ø THD, hnom:5" (127mm)**
Code Report: ICC-ES ESR-2713

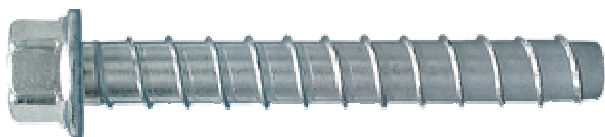



Company:		Date:	9/8/2022
Engineer:		Page:	2/5
Project:			
Address:			
Phone:			
E-mail:			

Load and Geometry

Load factor source: ACI 318 Section 5.3

Load combination: not set

Seismic design: No

Anchors subjected to sustained tension: Not applicable

Apply entire shear load at front row: No

Anchors only resisting wind and/or seismic loads: No

Strength level loads:

N_{ua} [lb]: 0

V_{uax} [lb]: 0

V_{uay} [lb]: -22720

M_{ux} [ft-lb]: 5680

M_{uy} [ft-lb]: 0

M_{uz} [ft-lb]: 0

<Figure 1>

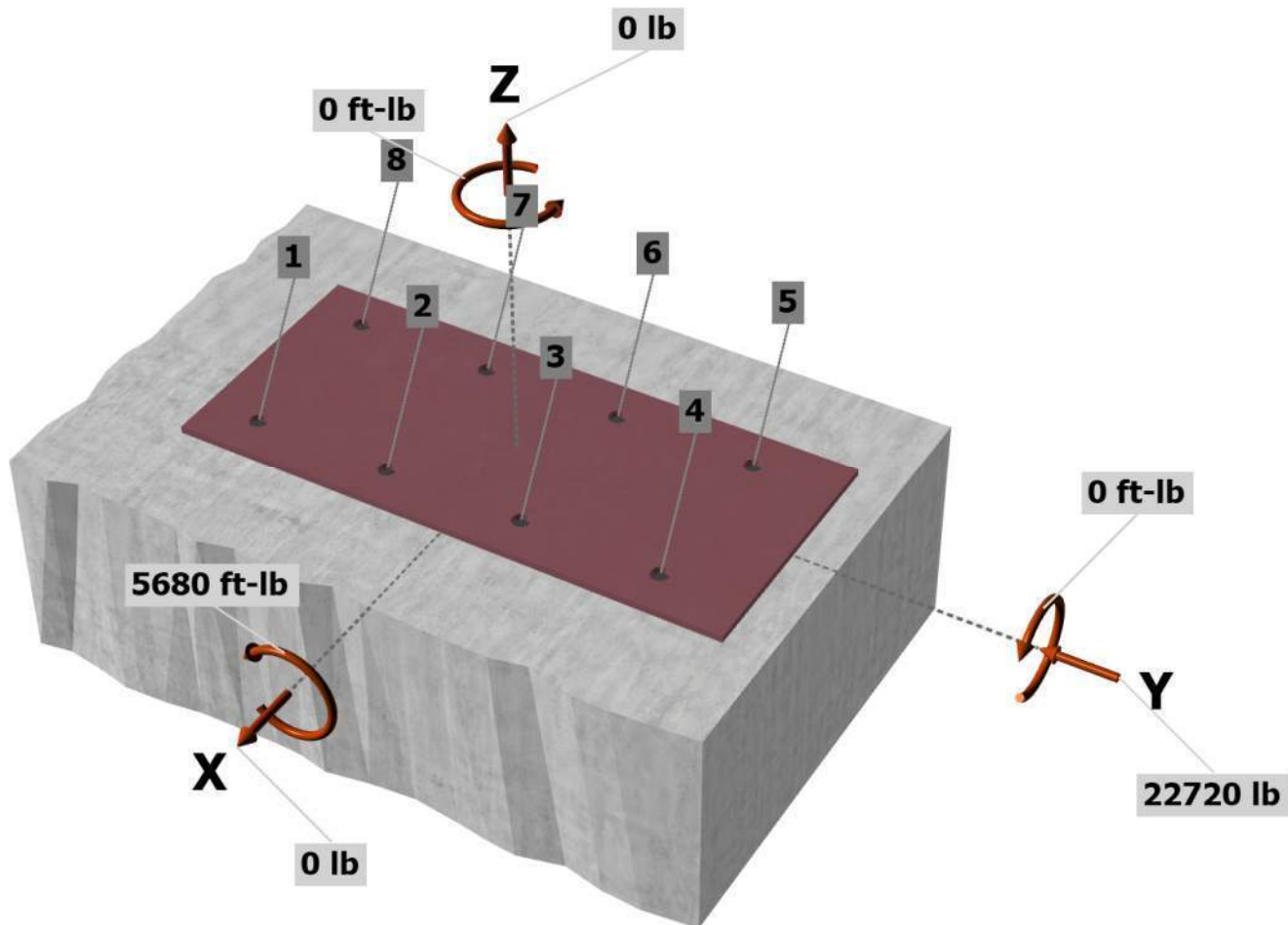

Input data and results must be checked for agreement with the existing circumstances, the standards and guidelines must be checked for plausibility.

Simpson Strong-Tie Company Inc. 5956 W. Las Positas Boulevard Pleasanton, CA 94588 Phone: 925.560.9000 Fax: 925.847.3871 www.strongtie.com

Company:		Date:	9/8/2022
Engineer:		Page:	3/5
Project:			
Address:			
Phone:			
E-mail:			

<Figure 2>

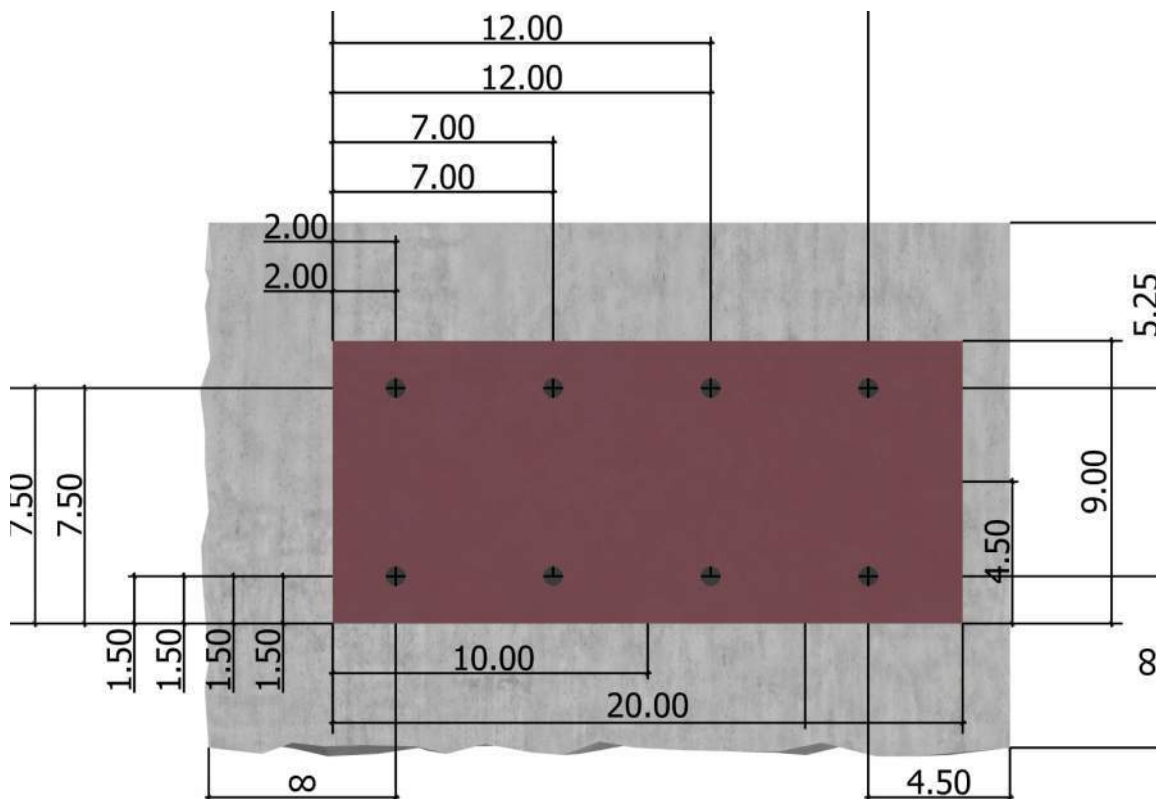

3. Resulting Anchor Forces

Anchor	Tension load, N_{ua} (lb)	Shear load x, V_{uax} (lb)	Shear load y, V_{uay} (lb)	Shear load combined, $\sqrt{(V_{uax})^2 + (V_{uay})^2}$ (lb)
1	0.0	0.0	-2840.0	2840.0
2	262.5	0.0	-2840.0	2840.0
3	893.5	0.0	-2840.0	2840.0
4	1524.4	0.0	-2840.0	2840.0
5	1524.4	0.0	-2840.0	2840.0
6	893.5	0.0	-2840.0	2840.0
7	262.5	0.0	-2840.0	2840.0
8	0.0	0.0	-2840.0	2840.0
Sum	5360.8	0.0	-22720.0	22720.0

Input data and results must be checked for agreement with the existing circumstances, the standards and guidelines must be checked for plausibility.



Company:		Date:	9/8/2022
Engineer:		Page:	4/5
Project:			
Address:			
Phone:			
E-mail:			

Maximum concrete compression strain (‰): 0.06
 Maximum concrete compression stress (psi): 242
 Resultant tension force (lb): 5361
 Resultant compression force (lb): 5361
 Eccentricity of resultant tension forces in x-axis, e'_{Nx} (inch): 2.35
 Eccentricity of resultant tension forces in y-axis, e'_{Ny} (inch): 0.00
 Eccentricity of resultant shear forces in x-axis, e'_{Vx} (inch): 0.00
 Eccentricity of resultant shear forces in y-axis, e'_{Vy} (inch): 0.00

<Figure 3>

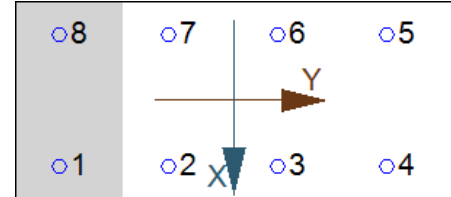

4. Steel Strength of Anchor in Tension (Sec. 17.6.1)

N_{sa} (lb)	ϕ	ϕN_{sa} (lb)
30360	0.65	19734

5. Concrete Breakout Strength of Anchor in Tension (Sec. 17.6.2)

$N_b = k_c \lambda_a \sqrt{f'_c} h_{ef}^{1.5}$ (Eq. 17.6.2.2.1)

k_c	λ_a	f'_c (psi)	h_{ef} (in)	N_b (lb)
24.0	1.00	3000	3.820	9814

$\phi N_{cbg} = \phi (A_{Nc} / A_{Nco}) \psi_{ec,N} \psi_{ed,N} \psi_{c,N} \psi_{cp,N} N_b$ (Sec. 17.5.1.2 & Eq. 17.6.2.1a)

A_{Nc} (in ²)	A_{Nco} (in ²)	$c_{a,min}$ (in)	$\psi_{ec,N}$	$\psi_{ed,N}$	$\psi_{c,N}$	$\psi_{cp,N}$	N_b (lb)	ϕ	ϕN_{cbg} (lb)
343.51	131.33	4.50	0.709	0.936	1.00	0.997	9814	0.65	11027

6. Pullout Strength of Anchor in Tension (Sec. 17.6.3)

$\phi N_{pn} = \phi \psi_{c,P} \lambda_a N_p (f'_c / 2,500)^n$ (Sec. 17.5.1.2, Eq. 17.6.3.1 & Code Report)

$\psi_{c,P}$	λ_a	N_p (lb)	f'_c (psi)	n	ϕ	ϕN_{pn} (lb)
1.0	1.00	8588	3000	0.50	0.65	6115

Input data and results must be checked for agreement with the existing circumstances, the standards and guidelines must be checked for plausibility.



Company:		Date:	9/8/2022
Engineer:		Page:	5/5
Project:			
Address:			
Phone:			
E-mail:			

8. Steel Strength of Anchor in Shear (Sec. 17.7.1)

V_{sa} (lb)	ϕ_{grout}	ϕ	$\phi_{grout}\phi V_{sa}$ (lb)
10000	1.0	0.60	6000

9. Concrete Breakout Strength of Anchor in Shear (Sec. 17.7.2)

Shear parallel to edge in x-direction:

$$V_{by} = \min\{7(l_e/d_a)^{0.2}\sqrt{d_a}\lambda_a\sqrt{f_c}c_{a1}^{1.5}; 9\lambda_a\sqrt{f_c}c_{a1}^{1.5}\} \text{ (Eq. 17.7.2.2.1a \& Eq. 17.7.2.2.1b)}$$

l_e (in)	d_a (in)	λ_a	f_c (psi)	c_{a1} (in)	V_{by} (lb)
3.82	0.625	1.00	3000	5.25	5237

$$\phi V_{cbgx} = \phi (2)(A_{vc}/A_{vco})\Psi_{ec,v}\Psi_{ed,v}\Psi_{c,v}\Psi_{h,v}V_{by} \text{ (Sec. 17.5.1.2, 17.7.2.1(c) \& Eq. 17.7.2.1b)}$$

A_{vc} (in ²)	A_{vco} (in ²)	$\Psi_{ec,v}$	$\Psi_{ed,v}$	$\Psi_{c,v}$	$\Psi_{h,v}$	V_{by} (lb)	ϕ	ϕV_{cbgx} (lb)
215.58	124.03	1.000	1.000	1.400	1.000	5237	0.70	17840

10. Concrete Pryout Strength of Anchor in Shear (Sec. 17.7.3)

$$\phi V_{cpq} = \phi k_{cp}N_{cbg} = \phi k_{cp}(A_{nc}/A_{nco})\Psi_{ec,n}\Psi_{ed,n}\Psi_{c,n}\Psi_{cp,n}N_b \text{ (Sec. 17.5.1.2 \& Eq. 17.7.3.1b)}$$

k_{cp}	A_{nc} (in ²)	A_{nco} (in ²)	$\Psi_{ec,n}$	$\Psi_{ed,n}$	$\Psi_{c,n}$	$\Psi_{cp,n}$	N_b (lb)	ϕ	ϕV_{cpq} (lb)
2.0	428.41	131.33	1.000	0.936	1.000	0.997	9814	0.70	41789

11. Results

Interaction of Tensile and Shear Forces (Sec. R17.8)

Tension	Factored Load, N_{ua} (lb)	Design Strength, ϕN_n (lb)	Ratio	Status	
Steel	1524	19734	0.08	Pass	
Concrete breakout	5361	11027	0.49	Pass (Governs)	
Pullout	1524	6115	0.25	Pass	
Shear	Factored Load, V_{ua} (lb)	Design Strength, ϕV_n (lb)	Ratio	Status	
Steel	2840	6000	0.47	Pass	
 Concrete breakout x- Pryout	11360	17840	0.64	Pass (Governs)	
	22720	41789	0.54	Pass	
Interaction check	$(N_{ua}/\phi N_{ua})^{5/3}$	$(V_{ua}/\phi V_{ua})^{5/3}$	Combined Ratio	Permissible	Status
Sec. R17.8	0.30	0.47	77.2%	1.0	Pass

5/8"Ø THD, hnom:5" (127mm) meets the selected design criteria.

12. Warnings

- Designer must exercise own judgement to determine if this design is suitable.
- Refer to manufacturer's product literature for hole cleaning and installation instructions.

Main Floor/Lower Wall, MB-03

1 piece(s) 5 1/2" x 12" 24F-V4 DF Glulam

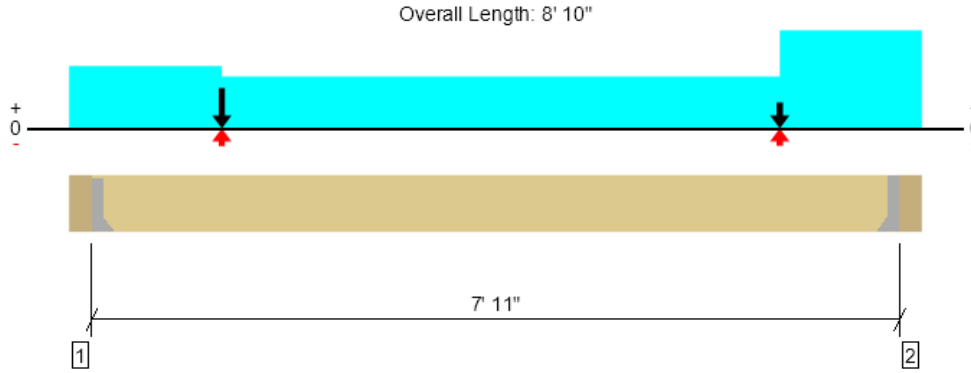

Drawing is Conceptual. All locations are measured from the outside face of left support (or left cantilever end). All dimensions are horizontal (typ.).

Design Results	Actual @ Location	Allowed	Result	LDF	Load: Combination (Pattern) [Group]
Member Reaction (lbs)	7162 @ 5 1/2"	7162 (2.00")	Passed (100%)	--	1.0 D + 1.0 L (All Spans) [1]
Shear (lbs)	6533 @ 1' 5 1/2"	11660	Passed (56%)	1.00	1.0 D + 1.0 L (All Spans) [8]
Pos Moment (Ft-lbs)	9316 @ 3' 4 9/16"	26400	Passed (35%)	1.00	1.0 D + 1.0 L (All Spans) [1]
Live Load Defl. (in)	0.050 @ 4' 3 3/8"	0.198	Passed (L/999+)	--	1.0 D + 1.0 L (All Spans) [1]
Total Load Defl. (in)	0.078 @ 4' 3 3/8"	0.396	Passed (L/999+)	--	1.0 D + 1.0 L (All Spans) [1]

Member Length : 7' 11"
 System : Floor
 Member Type : Flush Beam
 Building Use : Residential
 Building Code : IBC 2018
 Design Methodology : ASD

- Deflection criteria: LL (L/480) and TL (L/240).
- Allowed moment does not reflect the adjustment for the beam stability factor.
- Critical positive moment adjusted by a volume/size factor of 1.00 that was calculated using length L = 7' 11".
- The effects of positive or negative camber have not been accounted for when calculating deflection.
- The specified glulam is assumed to have its strong laminations at the bottom of the beam. Install with proper side up as indicated by the manufacturer.
- Applicable calculations are based on NDS.

Supports	Bearing Length			Loads to Supports (lbs)				Accessories
	Total	Available	Required	Dead	Floor Live	Snow	Factored	
1 - Hanger on 12" GLB beam	5.50"	Hanger ¹	2.00"	2719	4723	78/-59	7442	See note ¹
2 - Hanger on 12" GLB beam	5.50"	Hanger ¹	1.50"	2074	3612	33/-25	5685	See note ¹

- At hanger supports, the Total Bearing dimension is equal to the width of the material that is supporting the hanger
- ¹ See Connector grid below for additional information and/or requirements.

Lateral Bracing	Bracing Intervals	Comments
Top Edge (Lu)	7' 11" o/c	
Bottom Edge (Lu)	7' 11" o/c	

•Maximum allowable bracing intervals based on applied load.

Connector: Simpson Strong-Tie							
Support	Model	Seat Length	Top Fasteners	Face Fasteners	Member Fasteners	Accessories	
1 - Face Mount Hanger	HGUS5.50/10	4.00"	N/A	46-10d	16-10d		
2 - Face Mount Hanger	HGUS5.50/10	4.00"	N/A	46-10d	16-10d		

- Refer to manufacturer notes and instructions for proper installation and use of all connectors.

ForteWEB Software Operator	Job Notes
Mariam Soliman BTL Engineering PS (425) 814-8448 mariam.soliman@btleng.net	



9/29/2024 5:24:28 PM UTC
 ForteWEB v3.8, Engine: V8.4.1.24, Data: V8.1.6.3
 File Name: Dann Residence

Main Floor/Lower Wall, MB-04

1 piece(s) 5 1/2" x 15" 24F-V4 DF Glulam

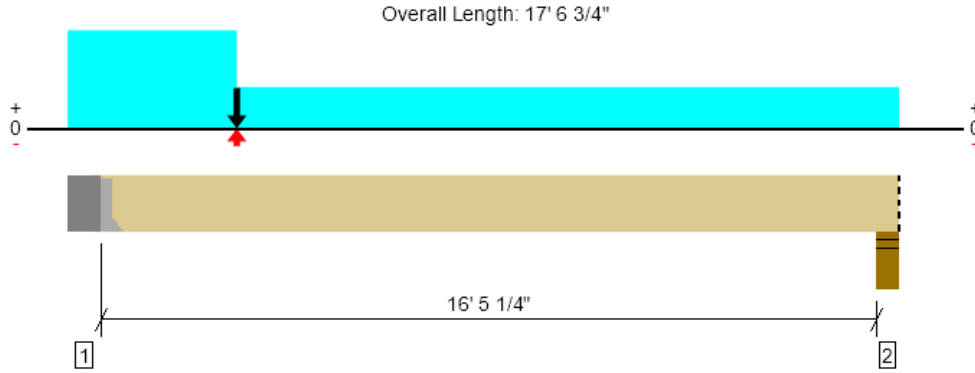

Drawing is Conceptual. All locations are measured from the outside face of left support (or left cantilever end). All dimensions are horizontal (typ.).

Design Results	Actual @ Location	Allowed	Result	LDF	Load: Combination (Pattern) [Group]
Member Reaction (lbs)	7217 @ 8"	7217 (2.02")	Passed (100%)	--	1.0 D + 1.0 L (All Spans) [1]
Shear (lbs)	6975 @ 1' 11"	14575	Passed (48%)	1.00	1.0 D + 1.0 L (All Spans) [1]
Pos Moment (Ft-lbs)	19393 @ 3' 5 1/2"	41018	Passed (47%)	1.00	1.0 D + 1.0 L (All Spans) [1]
Live Load Defl. (in)	0.170 @ 8' 11/16"	0.414	Passed (L/999+)	--	1.0 D + 1.0 L (All Spans) [1]
Total Load Defl. (in)	0.277 @ 8' 13/16"	0.828	Passed (L/717)	--	1.0 D + 1.0 L (All Spans) [1]

Member Length : 16' 10 3/4"
 System : Floor
 Member Type : Flush Beam
 Building Use : Residential
 Building Code : IBC 2018
 Design Methodology : ASD

- Deflection criteria: LL (L/480) and TL (L/240).
- Allowed moment does not reflect the adjustment for the beam stability factor.
- Critical positive moment adjusted by a volume/size factor of 0.99 that was calculated using length L = 16' 6 3/4".
- The effects of positive or negative camber have not been accounted for when calculating deflection.
- The specified glulam is assumed to have its strong laminations at the bottom of the beam. Install with proper side up as indicated by the manufacturer.
- Applicable calculations are based on NDS.

Supports	Bearing Length			Loads to Supports (lbs)				Accessories
	Total	Available	Required	Dead	Floor Live	Snow	Factored	
1 - Hanger on concrete	8.00"	Hanger ¹	2.02"	2928	4404	65/-49	7332	See note ¹
2 - Stud wall - HF	5.50"	5.50"	1.50"	827	1256	13/-10	2082	Blocking

- Blocking Panels are assumed to carry no loads applied directly above them and the full load is applied to the member being designed.
- At hanger supports, the Total Bearing dimension is equal to the width of the material that is supporting the hanger
- ¹ See Connector grid below for additional information and/or requirements.

Lateral Bracing	Bracing Intervals	Comments
Top Edge (Lu)	16' 11" o/c	
Bottom Edge (Lu)	16' 11" o/c	

•Maximum allowable bracing intervals based on applied load.

Connector: Simpson Strong-Tie						
Support	Model	Seat Length	Top Fasteners	Face Fasteners	Member Fasteners	Accessories
1 - Face Mount Hanger	HGUM5.50-SDS H=15	5.25"	N/A	8-THD62500H	24-SDS25212	

- Refer to manufacturer notes and instructions for proper installation and use of all connectors.

Vertical Loads	Location (Side)	Tributary Width	Dead (0.90)	Floor Live (1.00)	Snow (1.15)	Comments
0 - Self Weight (PLF)	8" to 17' 6 3/4"	N/A	20.0	--	--	
1 - Uniform (PSF)	0 to 17' 6 3/4" (Front)	1' 4"	15.0	40.0	-	Main Floor
2 - Uniform (PLF)	0 to 3' 5 1/2" (Front)	N/A	100.0	-	-	Wall
3 - Point (lb)	3' 5 1/2" (Front)	N/A	2719	4723	78/-59	Linked from: MB-03, Support 1

• Side loads are assumed to not induce cross-grain tension.

ForteWEB Software Operator	Job Notes
Mariam Soliman BTL Engineering PS (425) 814-8448 mariam.soliman@btleng.net	



9/29/2024 5:24:28 PM UTC
 ForteWEB v3.8, Engine: V8.4.1.24, Data: V8.1.6.3
 File Name: Dann Residence

Main Floor/Lower Wall, MB-05

1 piece(s) 5 1/2" x 15" 24F-V4 DF Glulam

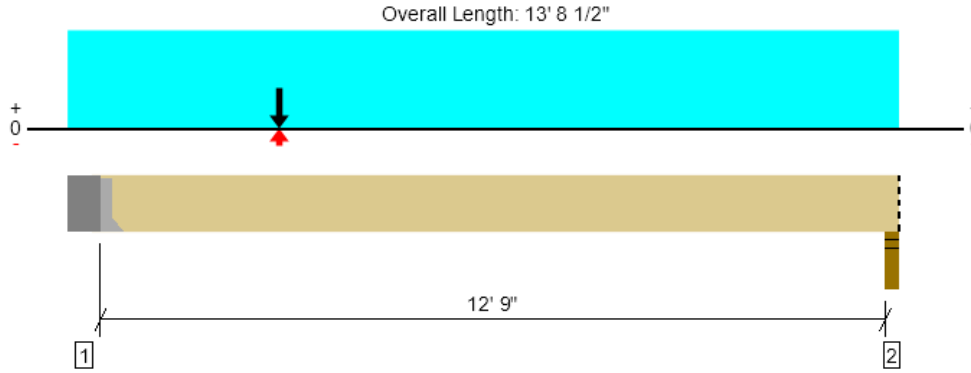

Drawing is Conceptual. All locations are measured from the outside face of left support (or left cantilever end). All dimensions are horizontal (typ.).

Design Results	Actual @ Location	Allowed	Result	LDF	Load: Combination (Pattern) [Group]
Member Reaction (lbs)	5698 @ 8"	5698 (1.59")	Passed (100%)	--	1.0 D + 1.0 L (All Spans) [1]
Shear (lbs)	5456 @ 1' 11"	14575	Passed (37%)	1.00	1.0 D + 1.0 L (All Spans) [1]
Pos Moment (Ft-lbs)	15153 @ 3' 5 1/2"	41250	Passed (37%)	1.00	1.0 D + 1.0 L (All Spans) [1]
Live Load Defl. (in)	0.074 @ 6' 5 3/8"	0.322	Passed (L/999+)	--	1.0 D + 1.0 L (All Spans) [1]
Total Load Defl. (in)	0.140 @ 6' 6 11/16"	0.644	Passed (L/999+)	--	1.0 D + 1.0 L (All Spans) [1]

Member Length : 13' 1/2"
 System : Floor
 Member Type : Flush Beam
 Building Use : Residential
 Building Code : IBC 2018
 Design Methodology : ASD

- Deflection criteria: LL (L/480) and TL (L/240).
- Allowed moment does not reflect the adjustment for the beam stability factor.
- Critical positive moment adjusted by a volume/size factor of 1.00 that was calculated using length L = 12' 10 1/2".
- The effects of positive or negative camber have not been accounted for when calculating deflection.
- The specified glulam is assumed to have its strong laminations at the bottom of the beam. Install with proper side up as indicated by the manufacturer.
- Applicable calculations are based on NDS.

Supports	Bearing Length			Loads to Supports (lbs)				Accessories
	Total	Available	Required	Dead	Floor Live	Snow	Factored	
1 - Hanger on concrete	8.00"	Hanger ¹	1.59"	2606	3208	26/-20	5814	See note ¹
2 - Stud wall - HF	3.50"	3.50"	1.50"	1375	1135	7/-5	2510	Blocking

- Blocking Panels are assumed to carry no loads applied directly above them and the full load is applied to the member being designed.
- At hanger supports, the Total Bearing dimension is equal to the width of the material that is supporting the hanger
- ¹ See Connector grid below for additional information and/or requirements.

Lateral Bracing	Bracing Intervals	Comments
Top Edge (Lu)	13' 1" o/c	
Bottom Edge (Lu)	13' 1" o/c	

- Maximum allowable bracing intervals based on applied load.

Connector: Simpson Strong-Tie						
Support	Model	Seat Length	Top Fasteners	Face Fasteners	Member Fasteners	Accessories
1 - Face Mount Hanger	HGUM5.50-SDS H=15	5.25"	N/A	8-THD62500H	24-SDS25212	

- Refer to manufacturer notes and instructions for proper installation and use of all connectors.

Vertical Loads	Location (Side)	Tributary Width	Dead (0.90)	Floor Live (1.00)	Snow (1.15)	Comments
0 - Self Weight (PLF)	8" to 13' 8 1/2"	N/A	20.0	--	--	
1 - Uniform (PSF)	0 to 13' 8 1/2" (Front)	8"	15.0	40.0	-	Main Floor
2 - Uniform (PLF)	0 to 13' 8 1/2" (Front)	N/A	100.0	-	-	Wall
3 - Uniform (PSF)	0 to 13' 8 1/2" (Front)	8"	15.0	40.0	-	Upper Floor
4 - Point (lb)	3' 5 1/2" (Front)	N/A	2074	3612	33/-25	Linked from: MB-03, Support 2

- Side loads are assumed to not induce cross-grain tension.

ForteWEB Software Operator	Job Notes
Mariam Soliman BTL Engineering PS (425) 814-8448 mariam.soliman@btleng.net	



9/29/2024 5:24:28 PM UTC
 ForteWEB v3.8, Engine: V8.4.1.24, Data: V8.1.6.3
 File Name: Dann Residence

Main Floor/Lower Wall, MB-06

1 piece(s) 3 1/2" x 15" 24F-V4 DF Glulam

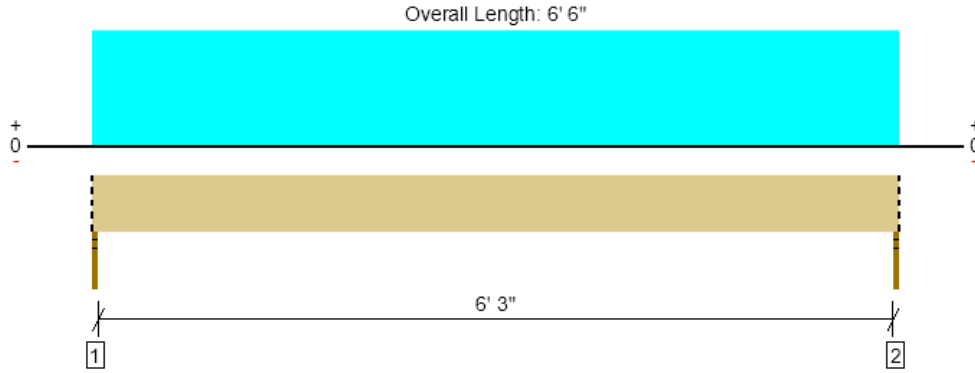

Drawing is Conceptual. All locations are measured from the outside face of left support (or left cantilever end). All dimensions are horizontal (typ.).

Design Results	Actual @ Location	Allowed	Result	LDF	Load: Combination (Pattern)
Member Reaction (lbs)	1541 @ 0	2126 (1.50")	Passed (72%)	--	1.0 D + 1.0 L (All Spans)
Shear (lbs)	889 @ 1' 4 1/2"	9275	Passed (10%)	1.00	1.0 D + 1.0 L (All Spans)
Pos Moment (Ft-lbs)	2504 @ 3' 3"	26250	Passed (10%)	1.00	1.0 D + 1.0 L (All Spans)
Live Load Defl. (in)	0.006 @ 3' 3"	0.162	Passed (L/999+)	--	1.0 D + 1.0 L (All Spans)
Total Load Defl. (in)	0.011 @ 3' 3"	0.325	Passed (L/999+)	--	1.0 D + 1.0 L (All Spans)

Member Length : 6' 6"
 System : Floor
 Member Type : Flush Beam
 Building Use : Residential
 Building Code : IBC 2018
 Design Methodology : ASD

- Deflection criteria: LL (L/480) and TL (L/240).
- Allowed moment does not reflect the adjustment for the beam stability factor.
- Critical positive moment adjusted by a volume/size factor of 1.00 that was calculated using length L = 6' 6".
- The effects of positive or negative camber have not been accounted for when calculating deflection.
- The specified glulam is assumed to have its strong laminations at the bottom of the beam. Install with proper side up as indicated by the manufacturer.
- Applicable calculations are based on NDS.

Supports	Bearing Length			Loads to Supports (lbs)			Accessories
	Total	Available	Required	Dead	Floor Live	Factored	
1 - Stud wall - HF	1.50"	1.50"	1.50"	691	850	1541	Blocking
2 - Stud wall - HF	1.50"	1.50"	1.50"	691	850	1541	Blocking

• Blocking Panels are assumed to carry no loads applied directly above them and the full load is applied to the member being designed.

Lateral Bracing	Bracing Intervals	Comments
Top Edge (Lu)	6' 6" o/c	
Bottom Edge (Lu)	6' 6" o/c	

•Maximum allowable bracing intervals based on applied load.

Vertical Loads	Location (Side)	Tributary Width	Dead (0.90)	Floor Live (1.00)	Comments
0 - Self Weight (PLF)	0 to 6' 6"	N/A	12.8	--	
1 - Uniform (PSF)	0 to 6' 6" (Front)	8"	15.0	40.0	Main Floor
2 - Uniform (PLF)	0 to 6' 6" (Front)	N/A	100.0	-	Wall
3 - Uniform (PSF)	0 to 6' 6" (Front)	8"	25.0	60.0	Upper Floor-Deck
4 - Uniform (PSF)	0 to 6' 6" (Front)	4' 10 1/2"	15.0	40.0	MainFloor-Deck

• Side loads are assumed to not induce cross-grain tension.

Weyerhaeuser Notes

Weyerhaeuser warrants that the sizing of its products will be in accordance with Weyerhaeuser product design criteria and published design values. Weyerhaeuser expressly disclaims any other warranties related to the software. Use of this software is not intended to circumvent the need for a design professional as determined by the authority having jurisdiction. The designer of record, builder or framer is responsible to assure that this calculation is compatible with the overall project. Accessories (Rim Board, Blocking Panels and Squash Blocks) are not designed by this software. Products manufactured at Weyerhaeuser facilities are third-party certified to sustainable forestry standards. Weyerhaeuser Engineered Lumber Products have been evaluated by ICC-ES under evaluation reports ESR-1153 and ESR-1387 and/or tested in accordance with applicable ASTM standards. For current code evaluation reports, Weyerhaeuser product literature and installation details refer to www.weyerhaeuser.com/woodproducts/document-library.

The product application, input design loads, dimensions and support information have been provided by ForteWEB Software Operator

ForteWEB Software Operator	Job Notes
Mariam Soliman BTL Engineering PS (425) 814-8448 mariam.soliman@btleng.net	



9/29/2024 5:24:28 PM UTC
 ForteWEB v3.8, Engine: V8.4.1.24, Data: V8.1.6.3
 File Name: Dann Residence

Main Floor/Lower Wall, MB-07

1 piece(s) 3 1/2" x 12" 24F-V4 DF Glulam

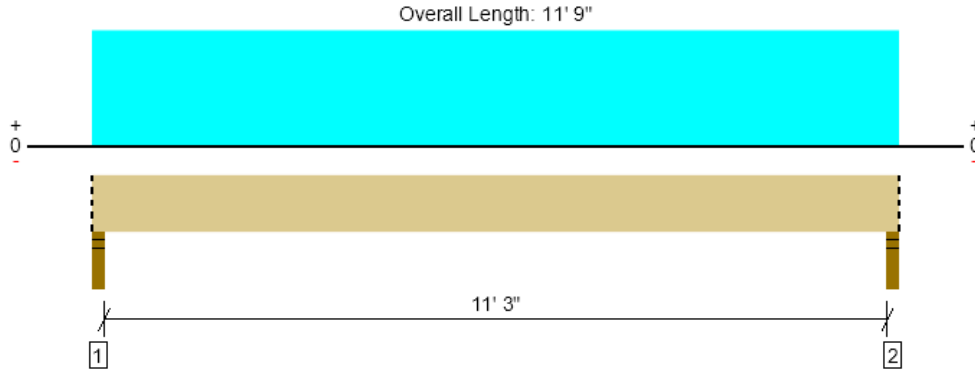

Drawing is Conceptual. All locations are measured from the outside face of left support (or left cantilever end). All dimensions are horizontal (typ.).

Design Results	Actual @ Location	Allowed	Result	LDF	Load: Combination (Pattern)
Member Reaction (lbs)	4234 @ 1 1/2"	4253 (3.00")	Passed (100%)	--	1.0 D + 1.0 L (All Spans)
Shear (lbs)	3333 @ 1' 3"	7420	Passed (45%)	1.00	1.0 D + 1.0 L (All Spans)
Pos Moment (Ft-lbs)	11913 @ 5' 10 1/2"	16800	Passed (71%)	1.00	1.0 D + 1.0 L (All Spans)
Live Load Defl. (in)	0.224 @ 5' 10 1/2"	0.287	Passed (L/616)	--	1.0 D + 1.0 L (All Spans)
Total Load Defl. (in)	0.313 @ 5' 10 1/2"	0.575	Passed (L/441)	--	1.0 D + 1.0 L (All Spans)

Member Length : 11' 9"
 System : Floor
 Member Type : Flush Beam
 Building Use : Residential
 Building Code : IBC 2018
 Design Methodology : ASD

- Deflection criteria: LL (L/480) and TL (L/240).
- Allowed moment does not reflect the adjustment for the beam stability factor.
- Critical positive moment adjusted by a volume/size factor of 1.00 that was calculated using length L = 11' 6".
- The effects of positive or negative camber have not been accounted for when calculating deflection.
- The specified glulam is assumed to have its strong laminations at the bottom of the beam. Install with proper side up as indicated by the manufacturer.
- Applicable calculations are based on NDS.

Supports	Bearing Length			Loads to Supports (lbs)			Accessories
	Total	Available	Required	Dead	Floor Live	Factored	
1 - Stud wall - HF	3.00"	3.00"	2.99"	1198	3035	4234	Blocking
2 - Stud wall - HF	3.00"	3.00"	2.99"	1198	3035	4234	Blocking

• Blocking Panels are assumed to carry no loads applied directly above them and the full load is applied to the member being designed.

Lateral Bracing	Bracing Intervals	Comments
Top Edge (Lu)	11' 9" o/c	
Bottom Edge (Lu)	11' 9" o/c	

•Maximum allowable bracing intervals based on applied load.

Vertical Loads	Location (Side)	Tributary Width	Dead (0.90)	Floor Live (1.00)	Comments
0 - Self Weight (PLF)	0 to 11' 9"	N/A	10.2	--	
1 - Uniform (PSF)	0 to 11' 9" (Front)	12' 11"	15.0	40.0	Main Floor

• Side loads are assumed to not induce cross-grain tension.

Weyerhaeuser Notes
 Weyerhaeuser warrants that the sizing of its products will be in accordance with Weyerhaeuser product design criteria and published design values. Weyerhaeuser expressly disclaims any other warranties related to the software. Use of this software is not intended to circumvent the need for a design professional as determined by the authority having jurisdiction. The designer of record, builder or framer is responsible to assure that this calculation is compatible with the overall project. Accessories (Rim Board, Blocking Panels and Squash Blocks) are not designed by this software. Products manufactured at Weyerhaeuser facilities are third-party certified to sustainable forestry standards. Weyerhaeuser Engineered Lumber Products have been evaluated by ICC-ES under evaluation reports ESR-1153 and ESR-1387 and/or tested in accordance with applicable ASTM standards. For current code evaluation reports, Weyerhaeuser product literature and installation details refer to www.weyerhaeuser.com/woodproducts/document-library.
 The product application, input design loads, dimensions and support information have been provided by ForteWEB Software Operator

ForteWEB Software Operator	Job Notes
Mariam Soliman BTL Engineering PS (425) 814-8448 mariam.soliman@btleng.net	



9/29/2024 5:55:56 PM UTC
 ForteWEB v3.8, Engine: V8.4.1.24, Data: V8.1.6.3
 File Name: Dann Residence

Main Floor/Lower Wall, MB-08

1 piece(s) 5 1/2" x 15" 24F-V4 DF Glulam

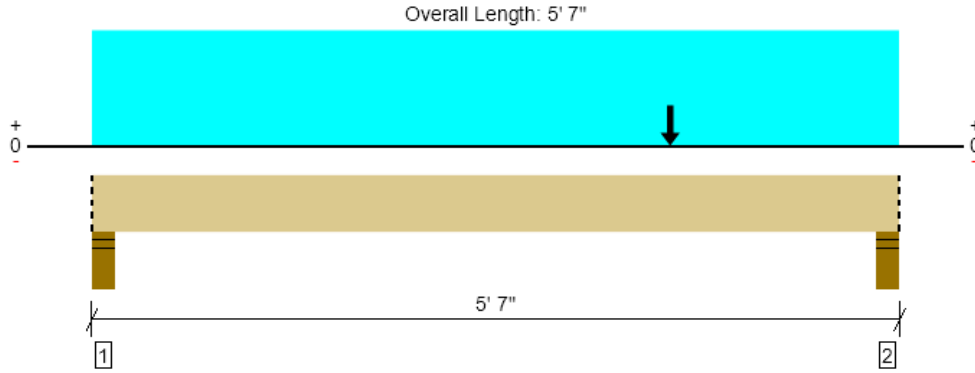

Drawing is Conceptual. All locations are measured from the outside face of left support (or left cantilever end). All dimensions are horizontal (typ.).

Design Results	Actual @ Location	Allowed	Result	LDF	Load: Combination (Pattern)
Member Reaction (lbs)	9804 @ 5' 3"	19663 (5.50")	Passed (50%)	--	1.0 D + 0.75 L + 0.75 S (All Spans)
Shear (lbs)	8386 @ 3' 10 1/2"	14575	Passed (58%)	1.00	1.0 D + 1.0 L (All Spans)
Pos Moment (Ft-lbs)	11692 @ 4'	41250	Passed (28%)	1.00	1.0 D + 1.0 L (All Spans)
Live Load Defl. (in)	0.008 @ 3' 3/8"	0.123	Passed (L/999+)	--	1.0 D + 0.75 L + 0.75 S (All Spans)
Total Load Defl. (in)	0.014 @ 3' 3/8"	0.246	Passed (L/999+)	--	1.0 D + 0.75 L + 0.75 S (All Spans)

Member Length : 5' 7"
 System : Floor
 Member Type : Flush Beam
 Building Use : Residential
 Building Code : IBC 2018
 Design Methodology : ASD

- Deflection criteria: LL (L/480) and TL (L/240).
- Allowed moment does not reflect the adjustment for the beam stability factor.
- Critical positive moment adjusted by a volume/size factor of 1.00 that was calculated using length L = 4' 11".
- The effects of positive or negative camber have not been accounted for when calculating deflection.
- The specified glulam is assumed to have its strong laminations at the bottom of the beam. Install with proper side up as indicated by the manufacturer.
- Applicable calculations are based on NDS.

Supports	Bearing Length			Loads to Supports (lbs)				Accessories
	Total	Available	Required	Dead	Floor Live	Snow	Factored	
1 - Stud wall - HF	5.50"	5.50"	1.54"	1478	1834	775	3434	Blocking
2 - Stud wall - LSL	5.50"	5.50"	2.74"	4173	5235	2272	9804	Blocking

• Blocking Panels are assumed to carry no loads applied directly above them and the full load is applied to the member being designed.

Lateral Bracing	Bracing Intervals	Comments
Top Edge (Lu)	5' 7" o/c	
Bottom Edge (Lu)	5' 7" o/c	

•Maximum allowable bracing intervals based on applied load.

Vertical Loads	Location (Side)	Tributary Width	Dead (0.90)	Floor Live (1.00)	Snow (1.15)	Comments
0 - Self Weight (PLF)	0 to 5' 7"	N/A	20.0	--	--	
1 - Uniform (PSF)	0 to 5' 7" (Front)	8"	15.0	40.0	-	Main Floor
2 - Point (lb)	4' (Front)	N/A	5483	6920	3047	Linked from: UB-06, Support 2

• Side loads are assumed to not induce cross-grain tension.

Weyerhaeuser Notes

Weyerhaeuser warrants that the sizing of its products will be in accordance with Weyerhaeuser product design criteria and published design values. Weyerhaeuser expressly disclaims any other warranties related to the software. Use of this software is not intended to circumvent the need for a design professional as determined by the authority having jurisdiction. The designer of record, builder or framer is responsible to assure that this calculation is compatible with the overall project. Accessories (Rim Board, Blocking Panels and Squash Blocks) are not designed by this software. Products manufactured at Weyerhaeuser facilities are third-party certified to sustainable forestry standards. Weyerhaeuser Engineered Lumber Products have been evaluated by ICC-ES under evaluation reports ESR-1153 and ESR-1387 and/or tested in accordance with applicable ASTM standards. For current code evaluation reports, Weyerhaeuser product literature and installation details refer to www.weyerhaeuser.com/woodproducts/document-library.

The product application, input design loads, dimensions and support information have been provided by ForteWEB Software Operator

ForteWEB Software Operator	Job Notes
Mariam Soliman BTL Engineering PS (425) 814-8448 mariam.soliman@btleng.net	



9/29/2024 5:24:28 PM UTC
 ForteWEB v3.8, Engine: V8.4.1.24, Data: V8.1.6.3
 File Name: Dann Residence

Main Floor/Lower Wall, MB-09

1 piece(s) 3 1/2" x 11 7/8" 1.55E TimberStrand® LSL

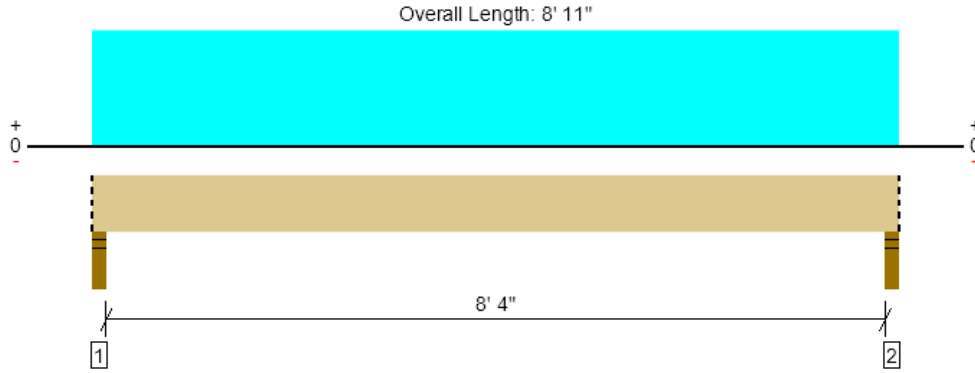

Drawing is Conceptual. All locations are measured from the outside face of left support (or left cantilever end). All dimensions are horizontal (typ.).

Design Results	Actual @ Location	Allowed	Result	LDF	Load: Combination (Pattern)
Member Reaction (lbs)	1782 @ 2"	4961 (3.50")	Passed (36%)	--	1.0 D + 1.0 L (All Spans)
Shear (lbs)	1270 @ 1' 3 3/8"	8590	Passed (15%)	1.00	1.0 D + 1.0 L (All Spans)
Moment (Ft-lbs)	3681 @ 4' 5 1/2"	15953	Passed (23%)	1.00	1.0 D + 1.0 L (All Spans)
Live Load Defl. (in)	0.055 @ 4' 5 1/2"	0.215	Passed (L/999+)	--	1.0 D + 1.0 L (All Spans)
Total Load Defl. (in)	0.078 @ 4' 5 1/2"	0.429	Passed (L/999+)	--	1.0 D + 1.0 L (All Spans)

Member Length : 8' 11"
 System : Floor
 Member Type : Flush Beam
 Building Use : Residential
 Building Code : IBC 2018
 Design Methodology : ASD

- Deflection criteria: LL (L/480) and TL (L/240).
- Allowed moment does not reflect the adjustment for the beam stability factor.

Supports	Bearing Length			Loads to Supports (lbs)			Accessories
	Total	Available	Required	Dead	Floor Live	Factored	
1 - Stud wall - HF	3.50"	3.50"	1.50"	526	1256	1782	Blocking
2 - Stud wall - HF	3.50"	3.50"	1.50"	526	1256	1782	Blocking

• Blocking Panels are assumed to carry no loads applied directly above them and the full load is applied to the member being designed.

Lateral Bracing	Bracing Intervals	Comments
Top Edge (Lu)	8' 11" o/c	
Bottom Edge (Lu)	8' 11" o/c	

•Maximum allowable bracing intervals based on applied load.

Vertical Loads	Location (Side)	Tributary Width	Dead (0.90)	Floor Live (1.00)	Comments
0 - Self Weight (PLF)	0 to 8' 11"	N/A	13.0	--	
1 - Uniform (PSF)	0 to 8' 11" (Front)	8"	15.0	40.0	MainFloor
2 - Uniform (PLF)	0 to 8' 11" (Front)	N/A	95.0	255.0	Stairs

• Side loads are assumed to not induce cross-grain tension.

Weyerhaeuser Notes

Weyerhaeuser warrants that the sizing of its products will be in accordance with Weyerhaeuser product design criteria and published design values. Weyerhaeuser expressly disclaims any other warranties related to the software. Use of this software is not intended to circumvent the need for a design professional as determined by the authority having jurisdiction. The designer of record, builder or framer is responsible to assure that this calculation is compatible with the overall project. Accessories (Rim Board, Blocking Panels and Squash Blocks) are not designed by this software. Products manufactured at Weyerhaeuser facilities are third-party certified to sustainable forestry standards. Weyerhaeuser Engineered Lumber Products have been evaluated by ICC-ES under evaluation reports ESR-1153 and ESR-1387 and/or tested in accordance with applicable ASTM standards. For current code evaluation reports, Weyerhaeuser product literature and installation details refer to www.weyerhaeuser.com/woodproducts/document-library.

The product application, input design loads, dimensions and support information have been provided by ForteWEB Software Operator

ForteWEB Software Operator	Job Notes
Mariam Soliman BTL Engineering PS (425) 814-8448 mariam.soliman@btleng.net	



9/29/2024 5:24:28 PM UTC
 ForteWEB v3.8, Engine: V8.4.1.24, Data: V8.1.6.3
 File Name: Dann Residence

Main Floor/Lower Wall, MB-10
1 piece(s) 4 x 8 DF No.2

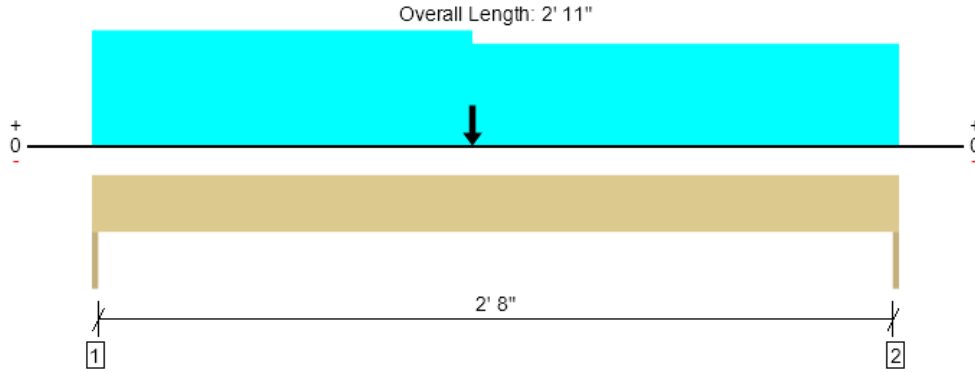

Drawing is Conceptual. All locations are measured from the outside face of left support (or left cantilever end). All dimensions are horizontal (typ.).

Design Results	Actual @ Location	Allowed	Result	LDF	Load: Combination (Pattern)
Member Reaction (lbs)	1793 @ 0	3281 (1.50")	Passed (55%)	--	1.0 D + 1.0 L (All Spans)
Shear (lbs)	1162 @ 8 3/4"	3045	Passed (38%)	1.00	1.0 D + 1.0 L (All Spans)
Moment (Ft-lbs)	1647 @ 1' 4 1/2"	2989	Passed (55%)	1.00	1.0 D + 1.0 L (All Spans)
Live Load Defl. (in)	0.009 @ 1' 5 1/2"	0.097	Passed (L/999+)	--	1.0 D + 1.0 L (All Spans)
Total Load Defl. (in)	0.013 @ 1' 5 7/16"	0.146	Passed (L/999+)	--	1.0 D + 1.0 L (All Spans)

Member Length : 2' 11"
 System : Wall
 Member Type : Header
 Building Use : Residential
 Building Code : IBC 2018
 Design Methodology : ASD

- Deflection criteria: LL (L/360) and TL (L/240).
- Allowed moment does not reflect the adjustment for the beam stability factor.
- Applicable calculations are based on NDS.

Supports	Bearing Length			Loads to Supports (lbs)			Accessories
	Total	Available	Required	Dead	Floor Live	Factored	
1 - Trimmer - SPF	1.50"	1.50"	1.50"	537	1256	1793	None
2 - Trimmer - SPF	1.50"	1.50"	1.50"	446	1212	1658	None

Lateral Bracing	Bracing Intervals	Comments
Top Edge (Lu)	2' 11" o/c	
Bottom Edge (Lu)	2' 11" o/c	

•Maximum allowable bracing intervals based on applied load.

Vertical Loads	Location	Tributary Width	Dead (0.90)	Floor Live (1.00)	Comments
0 - Self Weight (PLF)	0 to 2' 11"	N/A	6.4	--	
1 - Uniform (PSF)	0 to 2' 11"	6' 1 1/8"	12.0	40.0	Main Floor
2 - Uniform (PLF)	0 to 1' 4 1/2"	N/A	100.0	-	Wall
3 - Uniform (PSF)	0 to 2' 11"	8' 6"	12.0	40.0	Upper Floor
4 - Point (lb)	1' 4 1/2"	N/A	316	765	Linked from: UB-21, Support 1

Weyerhaeuser Notes

Weyerhaeuser warrants that the sizing of its products will be in accordance with Weyerhaeuser product design criteria and published design values. Weyerhaeuser expressly disclaims any other warranties related to the software. Use of this software is not intended to circumvent the need for a design professional as determined by the authority having jurisdiction. The designer of record, builder or framer is responsible to assure that this calculation is compatible with the overall project. Accessories (Rim Board, Blocking Panels and Squash Blocks) are not designed by this software. Products manufactured at Weyerhaeuser facilities are third-party certified to sustainable forestry standards. Weyerhaeuser Engineered Lumber Products have been evaluated by ICC-ES under evaluation reports ESR-1153 and ESR-1387 and/or tested in accordance with applicable ASTM standards. For current code evaluation reports, Weyerhaeuser product literature and installation details refer to www.weyerhaeuser.com/woodproducts/document-library.

The product application, input design loads, dimensions and support information have been provided by ForteWEB Software Operator

ForteWEB Software Operator	Job Notes
Mariam Soliman BTL Engineering PS (425) 814-8448 mariam.soliman@btleng.net	



9/29/2024 5:24:28 PM UTC
 ForteWEB v3.8, Engine: V8.4.1.24, Data: V8.1.6.3
 File Name: Dann Residence

Main Floor/Lower Wall, MB-11 (PT)

1 piece(s) 4 x 4 DF No.2

Overall Length: 5' 9 1/2"



Drawing is Conceptual. All locations are measured from the outside face of left support (or left cantilever end). All dimensions are horizontal (typ.).

Design Results	Actual @ Location	Allowed	Result	LDF	Load: Combination (Pattern)
Member Reaction (lbs)	371 @ 2"	7656 (3.50")	Passed (5%)	--	1.0 D + 1.0 L (All Spans)
Shear (lbs)	296 @ 7"	1470	Passed (20%)	1.00	1.0 D + 1.0 L (All Spans)
Moment (Ft-lbs)	477 @ 2' 10 3/4"	804	Passed (59%)	1.00	1.0 D + 1.0 L (All Spans)
Live Load Defl. (in)	0.100 @ 2' 10 3/4"	0.182	Passed (L/656)	--	1.0 D + 1.0 L (All Spans)
Total Load Defl. (in)	0.128 @ 2' 10 3/4"	0.273	Passed (L/512)	--	1.0 D + 1.0 L (All Spans)

Member Length : 5' 9 1/2"
 System : Floor
 Member Type : Drop Beam
 Building Use : Residential
 Building Code : IBC 2018
 Design Methodology : ASD

- Deflection criteria: LL (L/360) and TL (L/240).
- Allowed moment does not reflect the adjustment for the beam stability factor.
- Applicable calculations are based on NDS.
- This product has a square cross section. The analysis engine has checked both edge and plank orientations to allow for either installation.

Supports	Bearing Length			Loads to Supports (lbs)			Accessories
	Total	Available	Required	Dead	Floor Live	Factored	
1 - Column - DF	3.50"	3.50"	1.50"	81	290	371	Blocking
2 - Column - DF	3.50"	3.50"	1.50"	81	290	371	Blocking

• Blocking Panels are assumed to carry no loads applied directly above them and the full load is applied to the member being designed.

Lateral Bracing	Bracing Intervals	Comments
Top Edge (Lu)	5' 10" o/c	
Bottom Edge (Lu)	5' 10" o/c	

•Maximum allowable bracing intervals based on applied load.

Vertical Loads	Location (Side)	Tributary Width	Dead (0.90)	Floor Live (1.00)	Comments
0 - Self Weight (PLF)	0 to 5' 9 1/2"	N/A	3.1	--	
1 - Uniform (PSF)	0 to 5' 9 1/2" (Front)	1' 8"	15.0	60.0	Deck

• Side loads are assumed to not induce cross-grain tension.

Weyerhaeuser Notes

Weyerhaeuser warrants that the sizing of its products will be in accordance with Weyerhaeuser product design criteria and published design values. Weyerhaeuser expressly disclaims any other warranties related to the software. Use of this software is not intended to circumvent the need for a design professional as determined by the authority having jurisdiction. The designer of record, builder or framer is responsible to assure that this calculation is compatible with the overall project. Accessories (Rim Board, Blocking Panels and Squash Blocks) are not designed by this software. Products manufactured at Weyerhaeuser facilities are third-party certified to sustainable forestry standards. Weyerhaeuser Engineered Lumber Products have been evaluated by ICC-ES under evaluation reports ESR-1153 and ESR-1387 and/or tested in accordance with applicable ASTM standards. For current code evaluation reports, Weyerhaeuser product literature and installation details refer to www.weyerhaeuser.com/woodproducts/document-library.

The product application, input design loads, dimensions and support information have been provided by ForteWEB Software Operator

ForteWEB Software Operator	Job Notes
Mariam Soliman BTL Engineering PS (425) 814-8448 mariam.soliman@btleng.net	



9/29/2024 5:24:28 PM UTC
 ForteWEB v3.8, Engine: V8.4.1.24, Data: V8.1.6.3
 File Name: Dann Residence

Main Floor/Lower Wall, MB-12
1 piece(s) 6 x 10 DF No.2

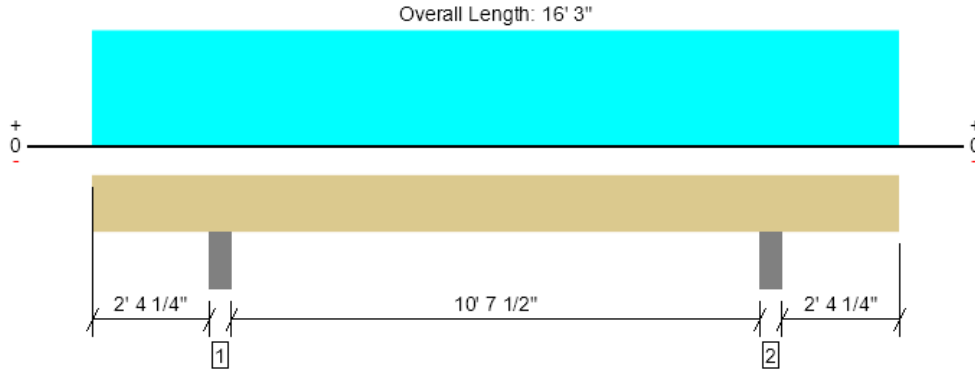

Drawing is Conceptual. All locations are measured from the outside face of left support (or left cantilever end). All dimensions are horizontal (typ.).

Design Results	Actual @ Location	Allowed	Result	LDF	Load: Combination (Pattern)
Member Reaction (lbs)	3731 @ 2' 7"	18906 (5.50")	Passed (20%)	--	1.0 D + 1.0 Lr (Adj Spans)
Shear (lbs)	2100 @ 3' 7 1/4"	7402	Passed (28%)	1.25	1.0 D + 1.0 Lr (Adj Spans)
Moment (Ft-lbs)	6028 @ 8' 1 1/2"	7540	Passed (80%)	1.25	1.0 D + 1.0 Lr (Alt Spans)
Live Load Defl. (in)	0.203 @ 8' 1 1/2"	0.369	Passed (L/654)	--	1.0 D + 1.0 Lr (Alt Spans)
Total Load Defl. (in)	0.253 @ 8' 1 1/2"	0.554	Passed (L/526)	--	1.0 D + 1.0 Lr (Alt Spans)

Member Length : 16' 3"
 System : Floor
 Member Type : Drop Beam
 Building Use : Residential
 Building Code : IBC 2018
 Design Methodology : ASD

- Deflection criteria: LL (L/360) and TL (L/240).
- Overhang deflection criteria: LL (2L/360) and TL (2L/240).
- Allowed moment does not reflect the adjustment for the beam stability factor.
- Lumber grading provisions must be extended over the length of the member per NDS 4.2.5.5.
- Applicable calculations are based on NDS.

Supports	Bearing Length			Loads to Supports (lbs)			Accessories
	Total	Available	Required	Dead	Roof Live	Factored	
1 - Pocket - concrete	5.50"	5.50"	1.50"	821	2911	3731	None
2 - Pocket - concrete	5.50"	5.50"	1.50"	821	2911	3731	None

Lateral Bracing	Bracing Intervals	Comments
Top Edge (Lu)	16' 3" o/c	
Bottom Edge (Lu)	16' 3" o/c	

•Maximum allowable bracing intervals based on applied load.

Vertical Loads	Location (Side)	Tributary Width	Dead (0.90)	Roof Live (1.25)	Comments
0 - Self Weight (PLF)	0 to 16' 3"	N/A	13.2	--	
1 - Uniform (PLF)	0 to 16' 3" (Front)	N/A	87.8	351.8	Linked from: MJ-03, Support 1

• Side loads are assumed to not induce cross-grain tension.

Weyerhaeuser Notes

Weyerhaeuser warrants that the sizing of its products will be in accordance with Weyerhaeuser product design criteria and published design values. Weyerhaeuser expressly disclaims any other warranties related to the software. Use of this software is not intended to circumvent the need for a design professional as determined by the authority having jurisdiction. The designer of record, builder or framer is responsible to assure that this calculation is compatible with the overall project. Accessories (Rim Board, Blocking Panels and Squash Blocks) are not designed by this software. Products manufactured at Weyerhaeuser facilities are third-party certified to sustainable forestry standards. Weyerhaeuser Engineered Lumber Products have been evaluated by ICC-ES under evaluation reports ESR-1153 and ESR-1387 and/or tested in accordance with applicable ASTM standards. For current code evaluation reports, Weyerhaeuser product literature and installation details refer to www.weyerhaeuser.com/woodproducts/document-library.

The product application, input design loads, dimensions and support information have been provided by ForteWEB Software Operator

ForteWEB Software Operator	Job Notes
Mariam Soliman BTL Engineering PS (425) 814-8448 mariam.soliman@btleng.net	



9/29/2024 5:24:28 PM UTC
 ForteWEB v3.8, Engine: V8.4.1.24, Data: V8.1.6.3
 File Name: Dann Residence

BTL

ENGINEERING

19011 Wood-Sno Road NE, Suite 100

Woodinville, WA 98072-4436

Phone: (425) 814-8448

Fax: (425) 821-2120

Lateral
Forces



Dann Residence
 3008 70th Avenue SE, Mercer Island, WA 98040

Revision Date: 1/29/2024

Criteria

Code: 2018 IBC
 Allowable Stress Design (ASD)

Seismic Design: ASCE 7-16: 12.8 Equivalent Lateral Force Procedure

Wind Design: ASCE 7-16: Ch. 28 Envelope Procedure, Low Rise

Risk Category: II - Other Structures Table 1.5-1

Snow Importance Factor $I_s = 1.00$ Table 1.5-2
 Ice Importance Factor - Thickness $I_i = 1.00$ Table 1.5-2
 Ice Importance Factor - Wind $I_w = 1.00$ Table 1.5-2
 Seismic Importance Factor $I_e = 1.00$ Table 1.5-2

Spectral Response, Short Period $S_s = 1.405$ (Mapped)

Spectral Response, 1-s Period $S_1 = 0.489$ (Mapped)

Site Class assumed, no Geotechnical Report

Site Class: D Table 20.3-1

Site Coefficient $F_a = 1.20$ Table 11.4-1

Site Coefficient $F_v = 1.81$ Table 11.4-2

Structural Systems:

Light framed walls with shear panels

All other structural systems $T_L = 6$ (Figs. 22-14 thru 22-17)

Response Modification Coefficient $R = 6.5$ Table 12.2-1

Overstrength Factor $\Omega_0 = 3$ Table 12.2-1

Deflection Amplification Factor $C_d = 4$ Table 12.2-1

Basic Wind Speed: 110 mph

Exposure to Wind: Exposure B Section 26.7.3

Topographical Factor $K_{ZT} = 1.60$

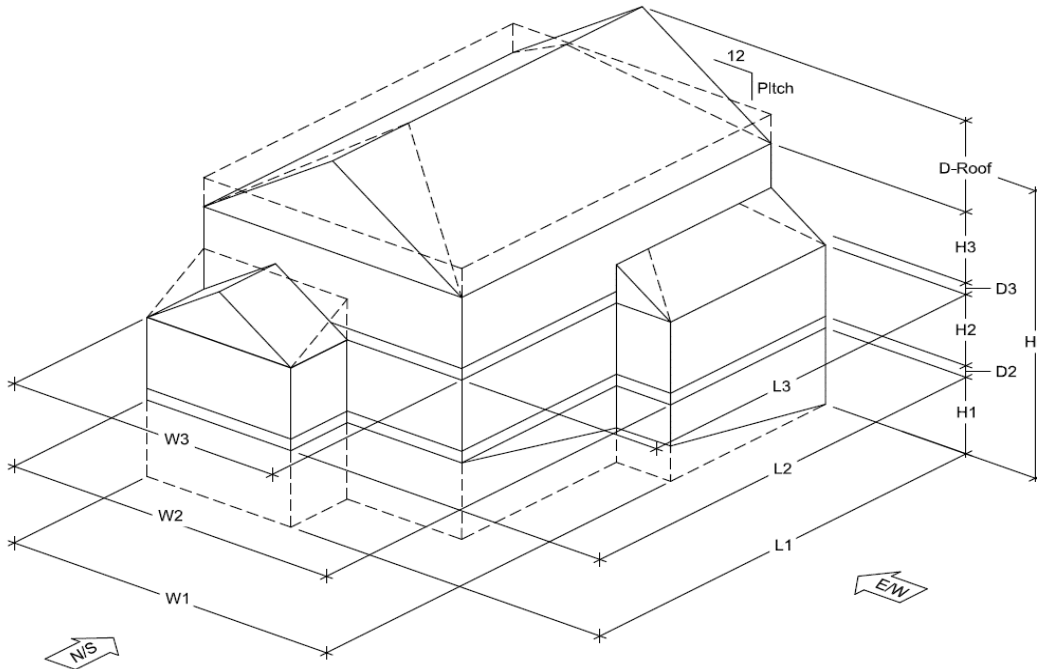

Roof			
Geometry			
Mean Roof Height	Hn =	31.36 ft	
Roof Depth	D-Roof =	2.95 ft	
Overhang Length		24 in	
Pitch		2:12	
Floor 2			
Geometry			
Width	W3 =	46.8 ft	
Length	L3 =	39.92 ft	
Plate Height	H3 =	9.5 ft	
Floor Depth	D3 =	13 in	
Floor 1			
Geometry			
Width	W2 =	46.67 ft	
Length	L2 =	39.92 ft	
Plate Height	H2 =	10 ft	
Floor Depth	D2 =	11 in	
Basement			
Geometry			
Width	W1 =	46.67 ft	
Length	L1 =	39.9 ft	
Plate Height	H1 =	8 ft	

Seismic Weight - Roof				
Roof Area 1	1675 SF	15 psf		25,125#
Roof Area 2				
Roof Area 3				
Exterior Wall 1	196.08 LF	4.75 ft	10 psf	9,314#
Exterior Wall 2				
Exterior Wall 3				
Interior Wall	112 LF	4.75 ft	8 psf	4,256#
				Total 38,695#
Seismic Weight - Floor 2				
Roof Area 1				
Floor Area 1	1109.5 SF	15 psf		16,643#
Floor Area 2				
Floor Area 3				
Exterior Wall 1	196.08 LF	4.75 ft	10 psf	9,314#
Exterior Wall 2	183 LF	5 ft	10 psf	9,150#
Exterior Wall 3				
Interior Wall1	112 LF	4.75 ft	8 psf	4,256#
Interior Wall2	32.17 LF	5 ft	8 psf	1,287#
				Total 40,649#
Seismic Weight - Floor 1				
Roof Area 1				
Floor Area 1	1377.3 SF	15 psf		20,659#
Floor Area 2				
Floor Area 3				
Exterior Wall 1	183 LF	5 ft	10 psf	9,150#
Exterior Wall 2	173.14 LF	4.2 ft	10 psf	7,272#
Exterior Wall 3				
Interior Wall1	32.17 LF	5 ft	8 psf	1,287#
Interior Wall2	78.5 LF	4.2 ft	8 psf	2,638#
				Total 41,005#

N/S Projected Area - Roof	
Sloped Roof Area	93 SF
Gable/Parapet Area	
Wall Area	222.3 SF
E/W Projected Area - Roof	
Sloped Roof Area	
Gable/Parapet Area	60 SF
Wall Area	189.62 SF
N/S Projected Area - Floor 2	
Sloped Roof Area	
Gable/Parapet Area	
Wall Area	506.59 SF
E/W Projected Area - Floor 2	
Sloped Roof Area	
Gable/Parapet Area	
Wall Area	432.67 SF
N/S Projected Area - Floor 1	
Sloped Roof Area	
Gable/Parapet Area	
Wall Area	471.17 SF
E/W Projected Area - Floor 1	
Sloped Roof Area	
Gable/Parapet Area	
Wall Area	402.94 SF

Dann Residence
 3008 70th Avenue SE, Mercer Island, WA 98040

Revision Date: 1/29/2024

Redundancy, $\rho = 1.0$ (Section 12.3.4)

Design Base Shear

$$S_{MS} = F_a S_S \quad (\text{Eq. 11.4-1})$$

$$= 1.686$$

$$S_{DS} = \frac{2}{3} S_{MS} \quad (\text{Eq. 11.4-3})$$

$$= 1.124$$

$$S_{M1} = F_v S_1 \quad (\text{Eq. 11.4-2})$$

$$= 0.886$$

$$S_{D1} = \frac{2}{3} S_{M1} \quad (\text{Eq. 11.4-4})$$

$$= 0.590$$

Seismic Design Category:

Short Period -- D
 1-Second Period -- D

Structure Period and Weight:

$$C_t = 0.020 \quad \text{Table 12.8-2}$$

$$x = 0.75$$

Building Height (Mean Roof), $h_n = 31$ ft

$$\text{Approximate Fundamental Period, } T_a = C_t (h_n)^x \quad (\text{Eq. 12.8-7})$$

$$T = T_a = 0.27$$

$$T_L = 6 \quad (\text{Figs. 22-14 thru 22-17})$$

Calculated design base shear:

$$V = C_s W \quad (\text{Eq. 12.8-1})$$

$$C_s = \frac{S_{DS}}{\left(\frac{R}{I_e}\right)} \quad (\text{Eq. 12.8-2})$$

$$C_s = 0.173$$

The total design base shear need not exceed:

$$(\text{Eq. 12.8-3}) \quad (\text{Eq. 12.8-4})$$

$$\text{for } T \leq T_L \quad C_s = \frac{S_{D1}}{T \left(\frac{R}{I_e}\right)} \quad \text{for } T > T_L \quad C_s = \frac{S_{D1} T_L}{T^2 \left(\frac{R}{I_e}\right)}$$

$$C_s = 0.343$$

$$C_s = 7.758$$

$$C_s = 0.343 \quad T \leq T_L$$

$$C_s = 0.514 \quad 1.5 \text{ times } C_s \text{ in accordance with 11.4.8}$$

The total design base shear shall not be less than:

$$C_s = 0.044 S_{DS} I_e \geq 0.01 \quad (\text{Eq. 12.8-5})$$

$$C_s = 0.049$$

nor where $S_1 \geq 0.6g$:

$$C_s = 0.5 S_1 / (R/I_e) \quad (\text{Eq. 12.8-6})$$

$$C_s = 0.000$$

$$C_s = 0.173$$

$$V = 0.173 W$$



19011 Wood-Sno Road NE, Suite 100
 Woodinville, WA 98072-4436
 Phone: 425-814-8448
 Fax: 425-821-2120

Dann Residence
 3008 70th Avenue SE, Mercer Island, WA 98040

Revision Date: 1/29/2024

$\rho_s = \lambda K_{ZT} \rho_{s30}$	(28.5-1)	Exposure =	B
$\lambda = 1.01$	(Fig. 28.5.1)	Mean Roof Ht hn (ft) =	31 ft
$K_{ZT} = 1.60$	(Section 26.8)	a (roof) =	4.0 ft
		a (upper/main floor) =	4.0 ft
		Basic Wind Speed =	110 mph
		Roof Angle =	10

North/South Loading 28.5.4 Minimum Design Loads

Zone	Area	p_{s30} (psf)	$p_{s30\ design}$ (psf)	ρ (psf)	Force (#)	ASD Force (#)	Force (#)	ASD Force (#)
Roof								
A _{wall}	38	21.6	21.6	34.9	1324	794	607	364
Agable	0	21.6	21.6	34.9	0	0	0	0
B	24	-9.0	0.0	0.0	0	0	188	113
C _{wall}	184	14.4	14.4	23.3	4291	2574	2950	1770
C _{gable}	0	14.4	14.4	23.3	0	0	0	0
D	69	-5.2	0.0	0.0	0	0	556	333
Total Area =	315				Total Load = 5614	3369	4301	2580
					Design : 5614	3369		
Floor 2								
A _{wall}	87	21.6	21.6	34.9	3020	1812	1384	831
Agable	0	21.6	21.6	34.9	0	0	0	0
B	0	-9.0	0.0	0.0	0	0	0	0
C _{wall}	420	14.4	14.4	23.3	9776	5865	6721	4033
C _{gable}	0	14.4	14.4	23.3	0	0	0	0
D	0	-5.2	0.0	0.0	0	0	0	0
Total Area =	507				Total Load = 12795	7677	8106	4863
					Design : 12795	7677		

East/West Loading 28.5.4 Minimum Design Loads

Zone	Area	p_{s30} (psf)	$p_{s30\ design}$ (psf)	ρ (psf)	Force (#)	ASD Force (#)	Force (#)	ASD Force (#)
Roof								
A _{wall}	38	21.6	21.6	34.9	1324	794	607	364
Agable	12	21.6	21.6	34.9	411	247	188	113
B	0	-9.0	0.0	0.0	0	0	0	0
C _{wall}	152	14.4	14.4	23.3	3530	2118	2427	1456
C _{gable}	48	14.4	14.4	23.3	1122	673	772	463
D	0	-5.2	0.0	0.0	0	0	0	0
Total Area =	250				Total Load = 6387	3832	3994	2396
					Design : 6387	3832		
Floor 2								
A _{wall}	82	21.6	21.6	34.9	2868	1721	1315	789
Agable	0	21.6	21.6	34.9	0	0	0	0
B	0	-9.0	0.0	0.0	0	0	0	0
C _{wall}	351	14.4	14.4	23.3	8156	4894	5608	3365
C _{gable}	0	14.4	14.4	23.3	0	0	0	0
D	0	-5.2	0.0	0.0	0	0	0	0
Total Area =	433				Total Load = 11025	6615	6923	4154
					Design : 11025	6615		
Floor 1								
A _{wall}	81	21.6	21.6	34.9	2839	1703	1301	781
Agable	0	21.6	21.6	34.9	0	0	0	0
B	0	-9.0	0.0	0.0	0	0	0	0
C _{wall}	322	14.4	14.4	23.3	7484	4490	5146	3087
C _{gable}	0	14.4	14.4	23.3	0	0	0	0
D	0	-5.2	0.0	0.0	0	0	0	0
Total Area =	403				Total Load = 10323	6194	6447	3868
					Design : 10323	6194		



Dann Residence
 3008 70th Avenue SE, Mercer Island, WA 98040

Revision Date: 1/29/2024

Vertical Distribution of Lateral Forces

Base Shear:

$$V = 20.81 \text{ kips}$$

Shear Walls:

$$F_x = C_{vx} V \quad (\text{Eq. 12.8-11})$$

$$C_{vx} = \frac{w_x h_x^k}{\sum_{i=1}^n w_i h_i^k} \quad (\text{Eq. 12.8-12})$$

Diaphragms:

$$F_{px} = \left(\sum_{i=x}^n F_i / \sum_{i=x}^n w_i \right) (w_{px}) \dots [\text{Eq. 12.10 - 1}]$$

$$F_{px} = 0.2 S_{DS} I_e w_{px} \dots [\text{Eq. 12.10 - 2}] (\text{min})$$

$$F_{px} = 0.4 S_{DS} I_e w_{px} \dots [\text{Eq. 12.10 - 3}] (\text{max})$$

Strength Design Seismic Forces (E)								
Floor Level (from base)	Height, h_x (ft)	Story Weight, w_x (Kips)	$w_x h_x$ (ft-Kips)	Lateral Force, F_x (Kips)	Story Shear, ΣF_x (Kips)	Story Moment (ft-Kips)	Portion of Weight at i , Σw_i (Kips)	Diaphragm Force, F_{px} (Kips)
Roof	22.1	38.69	854	8.98	8.98	99	39	8.98
Floor 2	11.1	40.65	451	4.74	13.72	251	79	9.14
Floor 1	-	41.01	-	7.09	20.81	-	120	9.22

Totals $W = 120.35$ Kips
 $\Sigma w_x h_x = 1304$ ft-Kips

Strength Design Wind Forces (W)				
Floor Level (from base)	Lateral Force N/S, H_x (Kips)	Story Shear N/S, ΣH_x (Kips)	Lateral Force E/W, H_x (Kips)	Story Shear E/W, ΣH_x (Kips)
Roof	5.61	5.61	6.39	6.39
Floor 2	12.80	18.41	11.02	17.41
Floor 1	-	-	10.32	27.73

	Diaphragm (ASD)		
	Seismic, [0.7E] (kips)	Wind N/S [0.6W] (kips)	Wind E/W [0.6W] (kips)
Roof	6.29	3.37	3.83
Floor 2	6.40	7.68	6.61
Floor 1	6.45	-	6.19

	Shear Walls (ASD)		
	Seismic, [0.7E] (kips)	Wind N/S [0.6W] (kips)	Wind E/W [0.6W] (kips)
Floor 2	6.29	3.37	3.83
Floor 1	3.32	7.68	6.61
Basement	4.96	-	6.19

BTL

ENGINEERING

19011 Wood-Sno Road NE, Suite 100

Woodinville, WA 98072-4436

Phone: (425) 814-8448

Fax: (425) 821-2120

Lateral
Shear Walls/Diaphragms

Roof Diaphragm

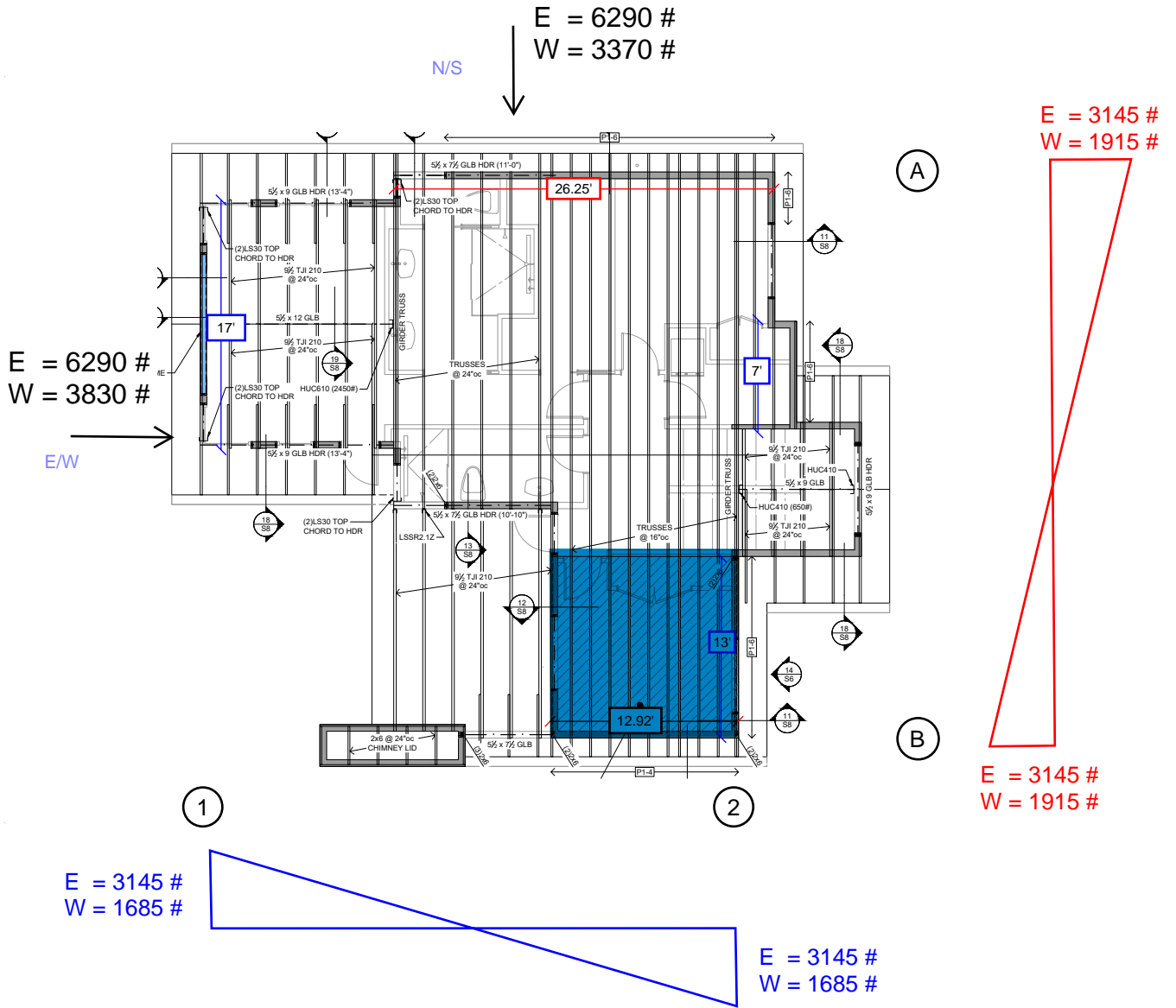

① (E) 3145 #/17' = 185 plf
 (W) 1685 #/17' = 100 plf

② (E) (30%)3145 #/7' = 135 plf
 (W) (30%)1685 #/7' = 72 plf

UNBLOCKED

Ⓐ (E) 3145 #/26.25' = 112 plf
 (W) 1915 #/26.25' = 73 plf

Ⓑ (E) 3145 #/12.92' = 243 plf **BLOCKED**
 (W) 1915 #/12.92' = 148 plf

Upper Floor Diaphragm

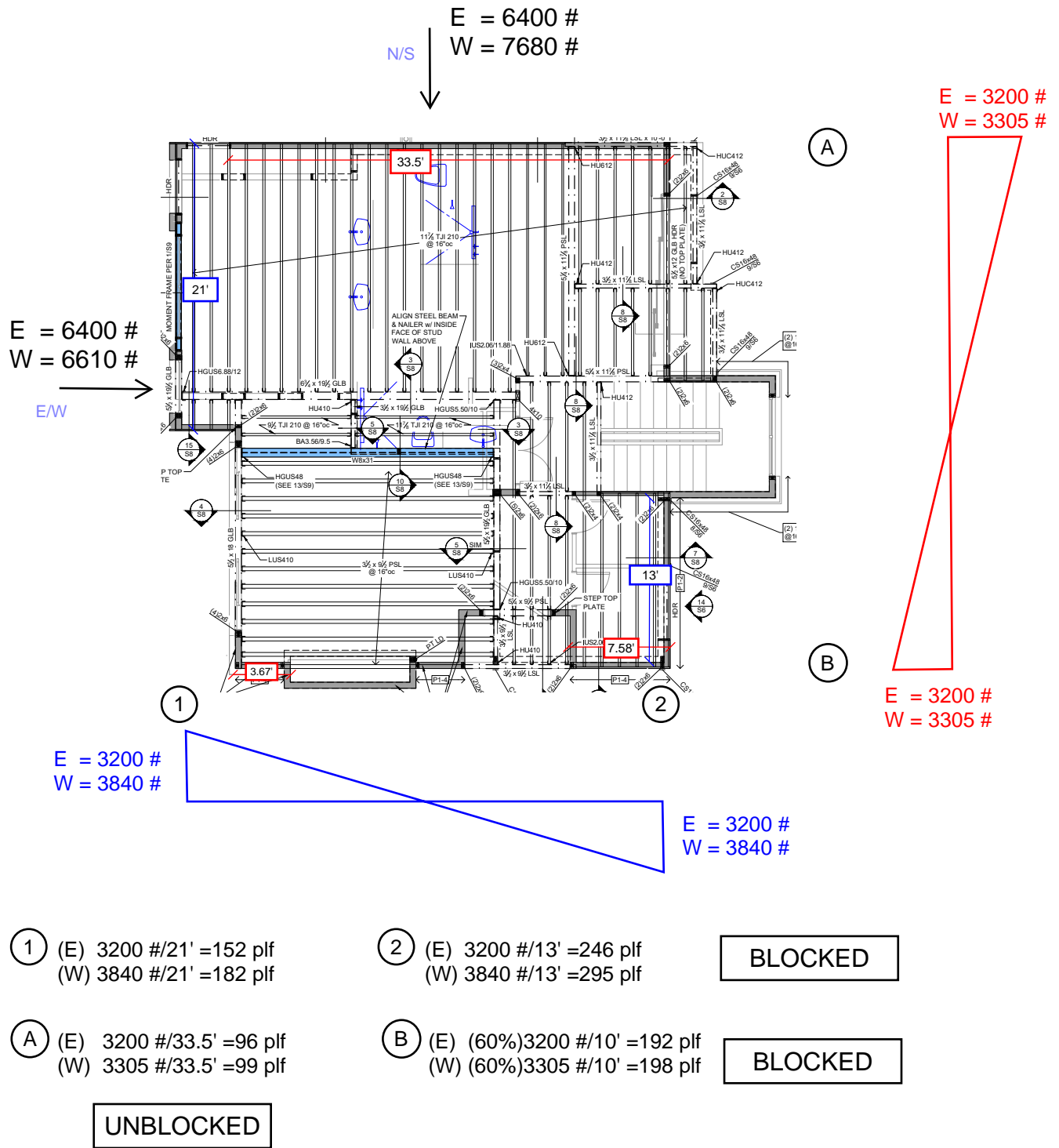

Main Floor Diaphragm

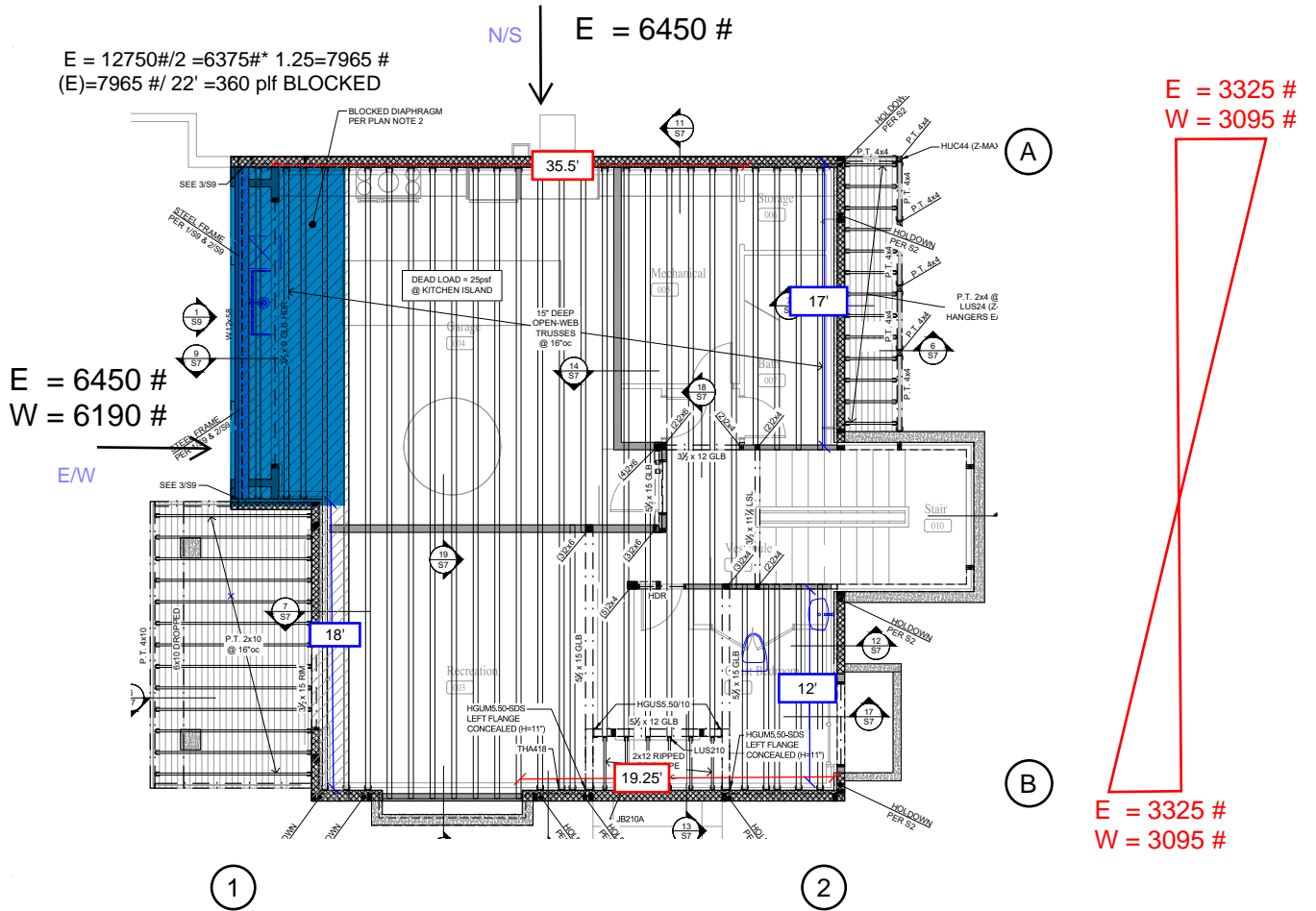

UNBLOCKED

Upper Floor Shear Forces

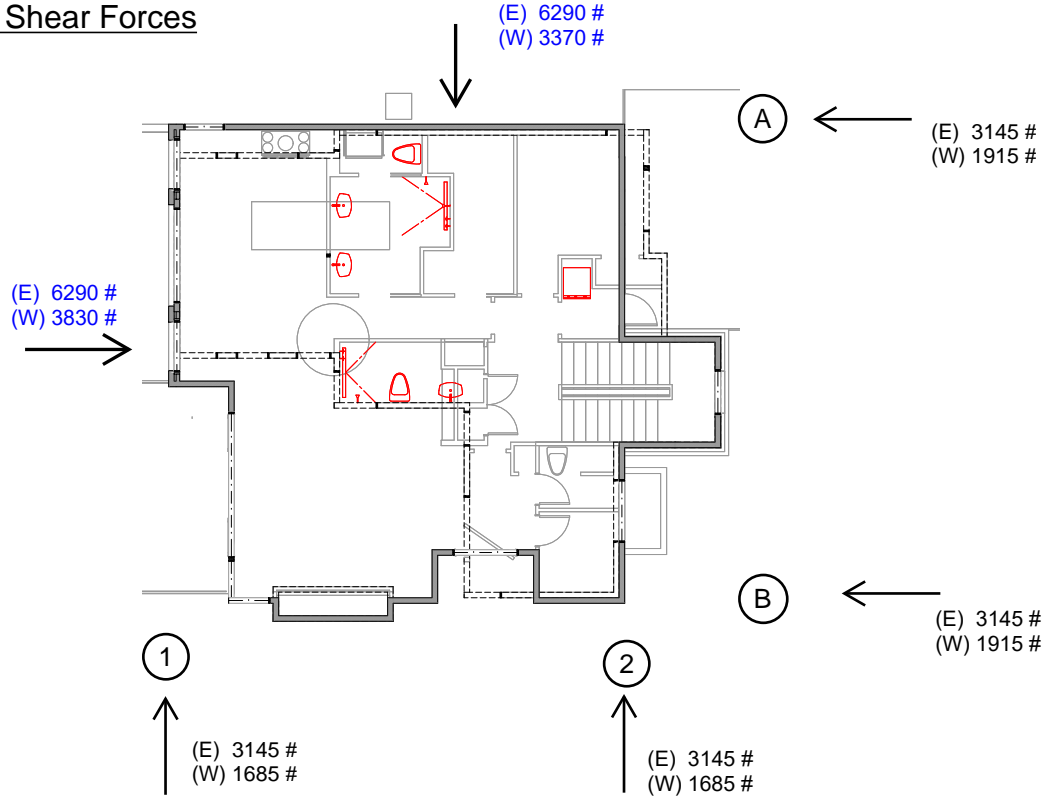

Main Floor Shear Forces

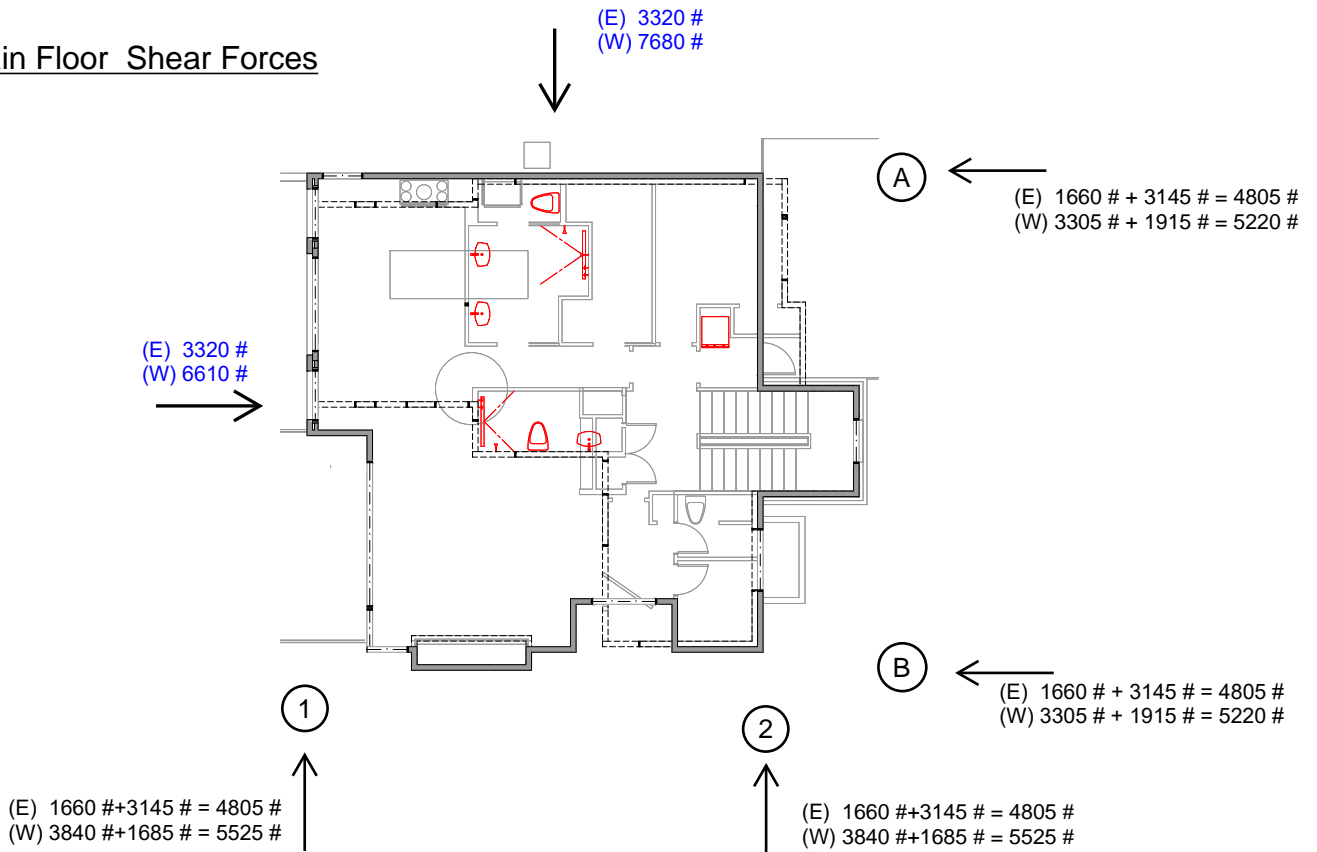

Project: **Dann Residence**

Designed By: **MS** Date: _____

Project Number: _____ Client: _____ Scale: _____ Page: **L2.4**

Lower Floor Shear Forces

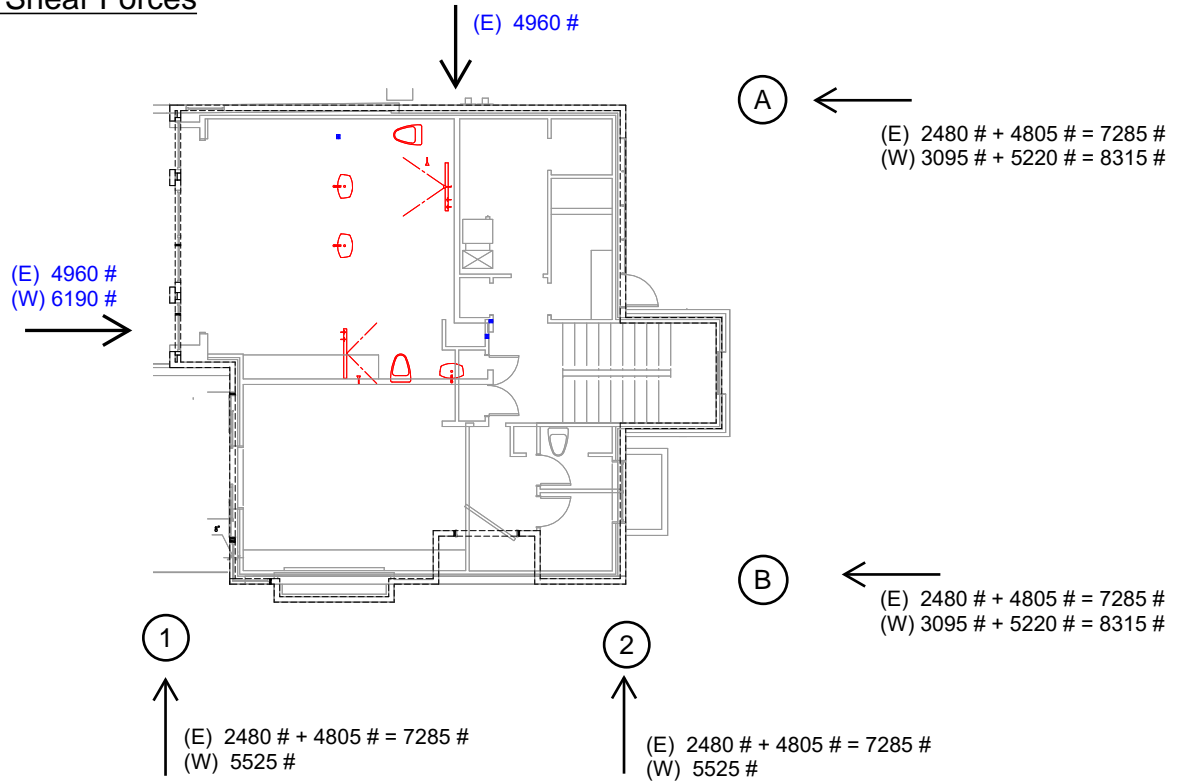

Shear Wall Line ①

E= 3145 #

W= 1685 #

3rd Floor: 9.5' PLT

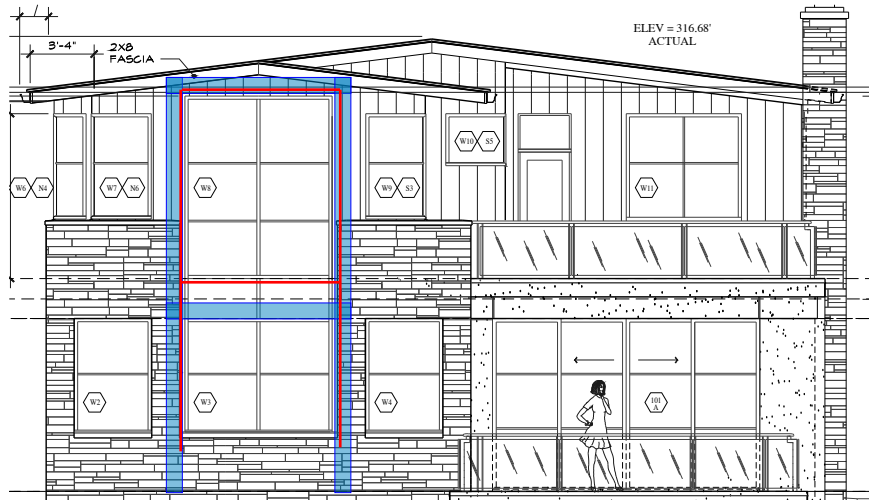

*See following page for Moment Frame Design

E= 4805 #

W= 5525 #

2nd Floor: 10' PLT

E= 7285 #

W= 5525 #

1st Floor: 8' PLT

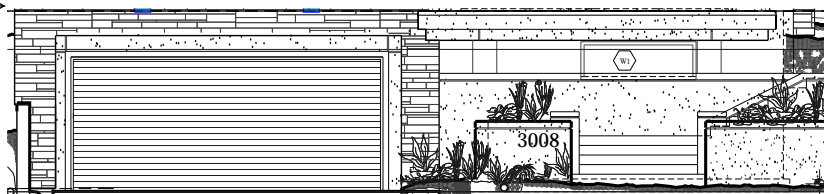

NO UPLIFT

5'

$$E = 7285 \# / [8'' * (5' * 12''/1)] = 15 \text{ psi}$$

$$W = 5525 \# / [8'' * (5' * 12''/1)] = 12 \text{ psi}$$

$$V_c = 2 * \text{sqrt}(f'_c) = 2 * \text{sqrt}(2500 \text{ psi}) = 100 \text{ psi}$$

Concrete Wall Ok

Project: **Dann Residence**

Designed By: MS Date: _____

Project Number: _____ Client: _____ Scale: _____ Page: **L2.6**

Shear Wall Line ① Steel Moment Frame

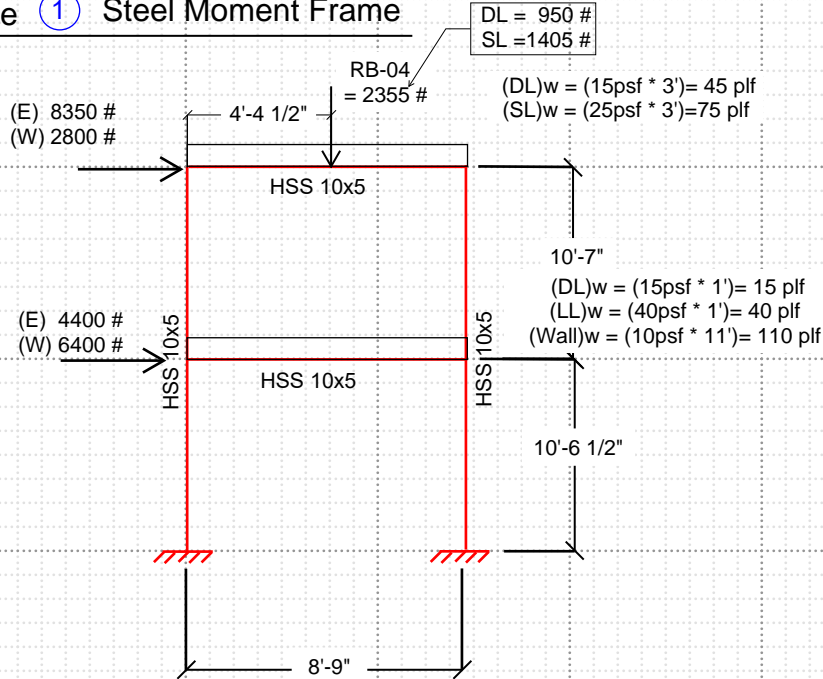

(E)

$$V = \frac{3.15k}{0.7} * \frac{0.321}{0.173} = 8.35K$$

$$V = \frac{1.66k}{0.7} * \frac{0.321}{0.173} = 4.4K$$

(W)

$$V = \frac{1.68k}{0.6} = 2.80K$$

$$V = \frac{3.84k}{0.6} = 6.40K$$

DEFLECTION WILL GOVERN THE DESIGN:

$$C_d * 0.025 * h_x = 0.025 * (21.125') * (12"/1') = 6.34" \quad 6.4"$$

$$6.4"/C_d = 6.4"/3 = 2.1"$$

$$C_d * 0.025 * h_x = 0.025 * (10.54') * (12"/1') = 3.162" \quad 3.2"$$

$$3.2"/C_d = 3.2"/3 = 1.1"$$

Node Coordinates

	Label	X [ft]	Y [ft]	Z [ft]	Detach From Diaphragm
1	N1	0	0	0	
2	N2	0	10.54	0	
3	N3	8.75	10.54	0	
4	N4	8.75	0	0	
5	N5	0	21.125	0	
6	N6	8.75	21.125	0	

Node Boundary Conditions

	Node Label	X [k/in]	Y [k/in]	Z [k/in]	Z Rot [k-ft/rad]
1	N1	Reaction	Reaction	Reaction	Reaction
2	N4	Reaction	Reaction	Reaction	Reaction
3	N5			Fixed	

Member Primary Data

	Label	I Node	J Node	Section/Shape	Type	Design List	Material	Design Rule
1	M1	N2	N3	HSS10X5X5	Beam	Tube	A992	Typical
2	M2	N1	N5	HSS10X5X5	Column	Tube	A992	Typical
3	M3	N4	N6	HSS10X5X5	Column	Tube	A992	Typical
4	M4	N5	N6	HSS10X5X5	Beam	Tube	A992	Typical

Envelope Node Reactions

	Node Label		X [k]	LC	Y [k]	LC	Z [k]	LC	MX [k-ft]	LC	MY [k-ft]	LC	MZ [k-ft]	LC
1	N1	max	6.266	25	18.996	25	0	27	0	27	0	27	40.596	24
2		min	-6.502	26	-14.384	26	0	1	0	1	0	1	-40.859	25
3	N4	max	6.494	27	19	24	0	27	0	27	0	27	40.797	24
4		min	-6.257	24	-14.38	27	0	1	0	1	0	1	-40.537	25
5	Totals:	max	12.75	27	8.391	23	0	27						
6		min	-12.75	26	3.689	27	0	1						

Envelope Node Displacements

	Node Label		X [in]	LC	Y [in]	LC	Z [in]	LC	X Rotation [rad]	LC	Y Rotation [rad]	LC	Z Rotation [rad]	LC
1	N1	max	0	26	0	26	0	27	0	27	0	27	0	25
2		min	0	25	0	25	0	1	0	1	0	1	0	24
3	N2	max	0.739	24	0.01	26	0	27	0	27	0	27	4.356e-3	27
4		min	-0.739	25	-0.013	25	0	1	0	1	0	1	-4.433e-3	24
5	N3	max	0.738	24	0.01	27	0	27	0	27	0	27	4.424e-3	25
6		min	-0.737	25	-0.013	24	0	1	0	1	0	1	-4.347e-3	26
7	N4	max	0	24	0	27	0	27	0	27	0	27	0	25
8		min	0	27	0	24	0	1	0	1	0	1	0	24
9	N5	max	1.486	24	0.013	26	0	27	0	27	0	27	2.43e-3	27
10		min	-1.486	25	-0.017	25	0	1	0	1	0	1	-2.768e-3	24
11	N6	max	1.483	24	0.013	27	0	27	0	27	0	27	2.763e-3	25
12		min	-1.483	25	-0.017	24	0	1	0	1	0	1	-2.425e-3	26

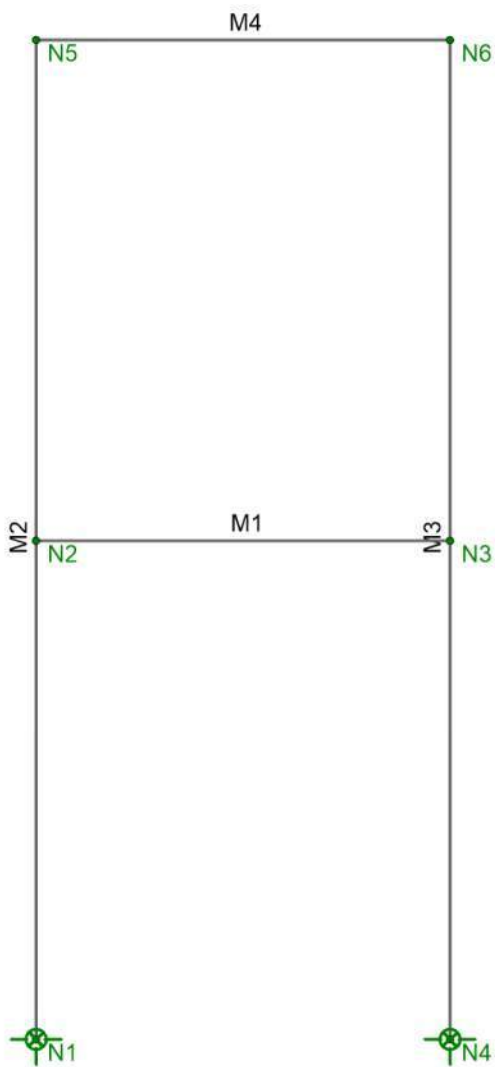
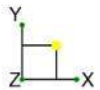

Envelope Only Solution

BTL Engineering

Mariam Soliman

Dann Residence Moment Frame

SK-1

May 28, 2024

Dann Moment Frame MS SW1.r3d

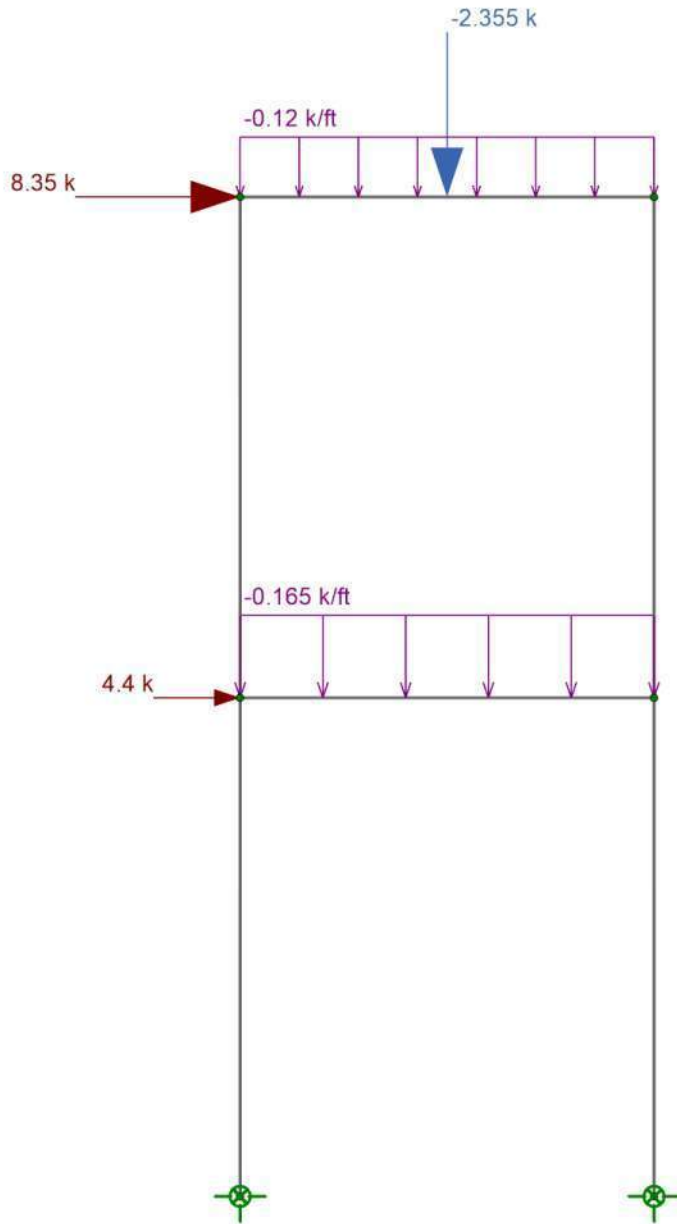
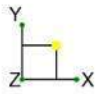

Loads: LC 2, Unfactored
Envelope Only Solution

BTL Engineering

Mariam Soliman

Dann Residence Moment Frame

SK-2

May 28, 2024

Dann Moment Frame MS SW1.r3d

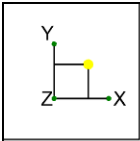

Results for LC 1, EQ Only

BTL Engineering

Mariam Soliman

Dann Residence Moment Frame

SK-3

May 28, 2024

Dann Moment Frame MS SW1.r3d

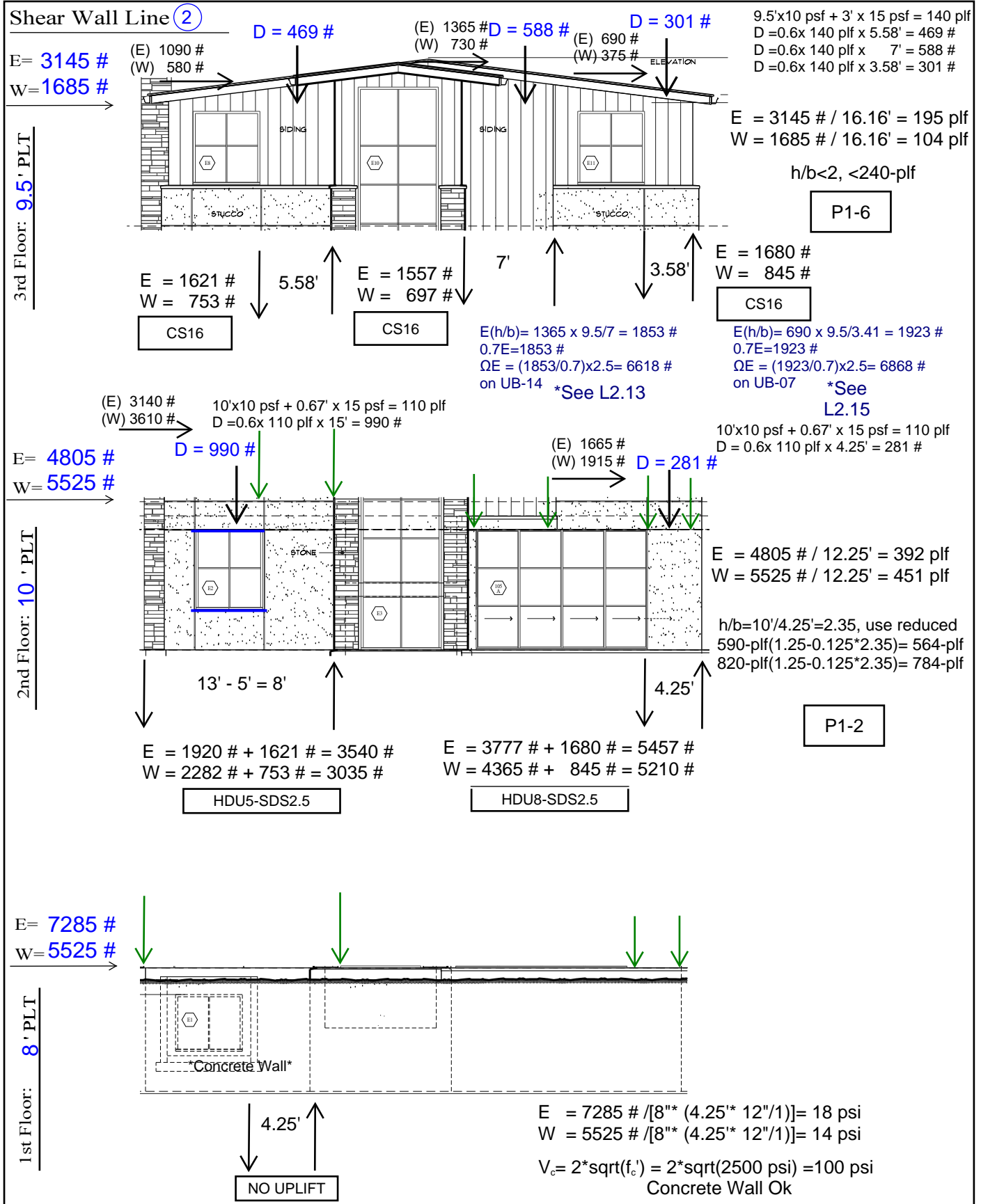

Project: Dann Residence Designed By: MS Date: _____

Project Number: _____ Client: _____ Scale: _____ Page: L2.12

Upper Floor/ Main Wall, UB-07-Overstrength
1 piece(s) 3 1/2" x 11 7/8" 1.55E TimberStrand® LSL

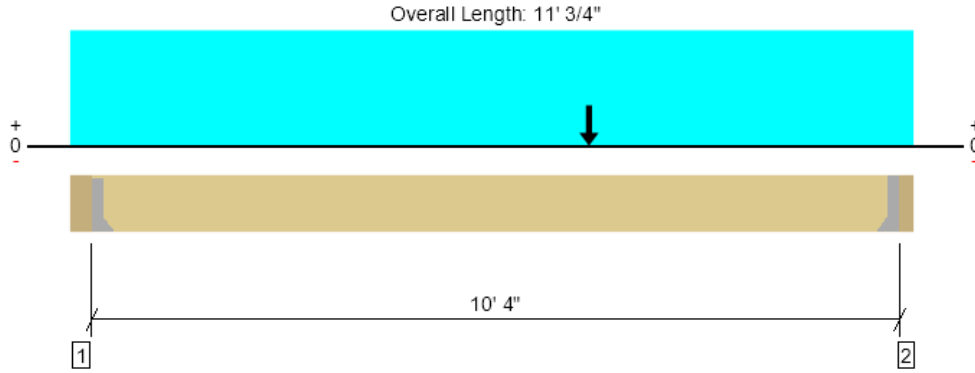

Drawing is Conceptual. All locations are measured from the outside face of left support (or left cantilever end). All dimensions are horizontal (typ.).

Design Results	Actual @ Location	Allowed	Result	LDF	Load: Combination (Pattern)
Member Reaction (lbs)	3779 @ 10' 9 1/4"	4725 (1.50")	Passed (80%)	--	1.0 D + 0.7 E (All Spans)
Shear (lbs)	3618 @ 9' 9 3/8"	13743	Passed (26%)	1.60	1.0 D + 0.7 E (All Spans)
Moment (Ft-lbs)	13877 @ 6' 9"	25525	Passed (54%)	1.60	1.0 D + 0.7 E (All Spans)
Live Load Defl. (in)	0.029 @ 5' 7 5/16"	0.258	Passed (L/999+)	--	1.0 D + 0.75 L + 0.75 S (All Spans)
Total Load Defl. (in)	0.092 @ 5' 7 5/16"	0.517	Passed (L/999+)	--	1.0 D + 0.75 L + 0.75 S (All Spans)

Member Length : 10' 4"
 System : Floor
 Member Type : Flush Beam
 Building Use : Residential
 Building Code : IBC 2018
 Design Methodology : ASD

- Deflection criteria: LL (L/480) and TL (L/240).
- Allowed moment does not reflect the adjustment for the beam stability factor.
- An excessive uplift of -1326 lbs detected at support located at 0".
- An excessive uplift of -2405 lbs detected at support located at 10' 4".

Supports	Bearing Length			Loads to Supports (lbs)					Accessories
	Total	Available	Required	Dead	Floor Live	Snow	Seismic	Factored	
1 - Hanger on 11 7/8" PSL beam	5.25"	Hanger ¹	1.50"	908	149	420	2672/-2672	2778/-1326	See note ¹
2 - Hanger on 11 7/8" LSL beam	3.50"	Hanger ¹	1.50"	886	146	409	4196/-4196	3823/-2405	See note ¹

- At hanger supports, the Total Bearing dimension is equal to the width of the material that is supporting the hanger
- ¹ See Connector grid below for additional information and/or requirements.

Lateral Bracing	Bracing Intervals	Comments
Top Edge (Lu)	10' 4" o/c	
Bottom Edge (Lu)	10' 4" o/c	

•Maximum allowable bracing intervals based on applied load.

Connector: Simpson Strong-Tie						
Support	Model	Seat Length	Top Fasteners	Face Fasteners	Member Fasteners	Accessories
1 - Face Mount Hanger	HGUS412	4.00"	N/A	56-10d	20-10d	
2 - Face Mount Hanger	HUS412	2.00"	N/A	10-16d	10-16d	

• Refer to manufacturer notes and instructions for proper installation and use of all connectors.

Vertical Loads	Location (Side)	Tributary Width	Dead (0.90)	Floor Live (1.00)	Snow (1.15)	Seismic (1.60)	Comments
0 - Self Weight (PLF)	5 1/4" to 10' 9 1/4"	N/A	13.0	--	--	--	
1 - Uniform (PSF)	0 to 11' 3/4" (Front)	8"	15.0	40.0	-	-	Upper Floor
2 - Uniform (PLF)	0 to 11' 3/4" (Front)	N/A	95.0	-	-	-	Wall
3 - Uniform (PSF)	0 to 11' 3/4" (Front)	3'	15.0	-	25.0	-	Roof
4 - Point (lb)	6' 9" (Front)	N/A	-	-	-	6868	PT Load Seismic ΩE=6868#

• Side loads are assumed to not induce cross-grain tension.

Forteweb Software Operator	Job Notes
Mariam Soliman BTL Engineering PS (425) 814-8448 mariam.soliman@btleng.net	



9/29/2024 6:48:39 PM UTC
 Forteweb v3.8, Engine: V8.4.1.24, Data: V8.1.6.3
 File Name: Dann Residence

Upper Floor/ Main Wall, UB-07-Connections
1 piece(s) 3 1/2" x 11 7/8" 1.55E TimberStrand® LSL

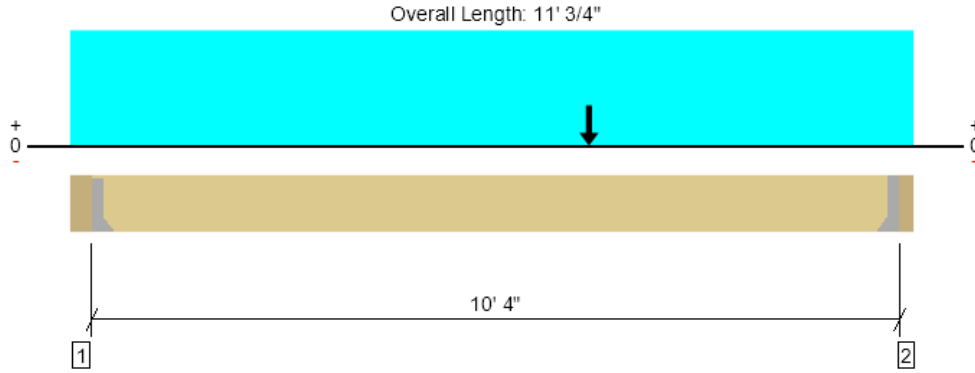

Drawing is Conceptual. All locations are measured from the outside face of left support (or left cantilever end). All dimensions are horizontal (typ.).

Design Results	Actual @ Location	Allowed	Result	LDF	Load: Combination (Pattern)
Member Reaction (lbs)	2117 @ 10' 9 1/4"	4725 (1.50")	Passed (45%)	--	1.0 D + 0.525 E + 0.75 L + 0.75 S (All Spans)
Shear (lbs)	1880 @ 9' 9 3/8"	13743	Passed (14%)	1.60	1.0 D + 0.525 E + 0.75 L + 0.75 S (All Spans)
Moment (Ft-lbs)	6792 @ 6' 9"	25525	Passed (27%)	1.60	1.0 D + 0.7 E (All Spans)
Live Load Defl. (in)	0.029 @ 5' 7 5/16"	0.258	Passed (L/999+)	--	1.0 D + 0.75 L + 0.75 S (All Spans)
Total Load Defl. (in)	0.092 @ 5' 7 5/16"	0.517	Passed (L/999+)	--	1.0 D + 0.75 L + 0.75 S (All Spans)

Member Length : 10' 4"
 System : Floor
 Member Type : Flush Beam
 Building Use : Residential
 Building Code : IBC 2018
 Design Methodology : ASD

- Deflection criteria: LL (L/480) and TL (L/240).
- Allowed moment does not reflect the adjustment for the beam stability factor.
- -204 lbs uplift at support located at 5 1/4". Strapping or other restraint may be required.
- -643 lbs uplift at support located at 10' 9 1/4". Strapping or other restraint may be required.

0.6D-0.7E
 = (0.6*908#)-(0.7*1069)
 = -204#--> uplift resolved by Straps

Supports	Bearing Length			Loads to Supports (lbs)					Accessories
	Total	Available	Required	Dead	Floor Live	Snow	Seismic	Factored	
1 - Hanger on 11 7/8" PSL beam	5.25"	Hanger ¹	1.50"	908	149	420	1069/-1069	1896/-204	See note ¹
2 - Hanger on 11 7/8" LSL beam	3.50"	Hanger ¹	1.50"	886	146	409	1678/-1678	2183/-643	See

- At hanger supports, the Total Bearing dimension is equal to the width of the material that is supporting the hanger
- ¹ See Connector grid below for additional information and/or requirements.

0.6D-0.7E
 = (0.6*886#)-(0.7*1678)
 = -643#--> uplift resolved Straps

Lateral Bracing	Bracing Intervals	Comments
Top Edge (Lu)	10' 4" o/c	
Bottom Edge (Lu)	10' 4" o/c	

•Maximum allowable bracing intervals based on applied load.

Connector: Simpson Strong-Tie						
Support	Model	Seat Length	Top Fasteners	Face Fasteners	Member Fasteners	Accessories
1 - Face Mount Hanger	LUS410	2.00"	N/A	8-10dx1.5	6-10d	
2 - Face Mount Hanger	LUS410	2.00"	N/A	8-10d	6-10d	

• Refer to manufacturer notes and instructions for proper installation and use of all connectors.

Vertical Loads	Location (Side)	Tributary Width	Dead (0.90)	Floor Live (1.00)	Snow (1.15)	Seismic (1.60)	Comments
0 - Self Weight (PLF)	5 1/4" to 10' 9 1/4"	N/A	13.0	--	--	--	
1 - Uniform (PSF)	0 to 11' 3/4" (Front)	8"	15.0	40.0	-	-	Upper Floor
2 - Uniform (PLF)	0 to 11' 3/4" (Front)	N/A	95.0	-	-	-	Wall
3 - Uniform (PSF)	0 to 11' 3/4" (Front)	3'	15.0	-	25.0	-	Roof
4 - Point (lb)	6' 9" (Front)	N/A	-	-	-	2747	PT Load Seismic E=6868#/2.5=2747

• Side loads are assumed to not induce cross-grain tension.

Forteweb Software Operator	Job Notes
Mariam Soliman BTL Engineering PS (425) 814-8448 mariam.soliman@btleng.net	



Upper Floor/ Main Wall, UB-14-Overstrength
1 piece(s) 3 1/2" x 11 7/8" 1.55E TimberStrand® LSL

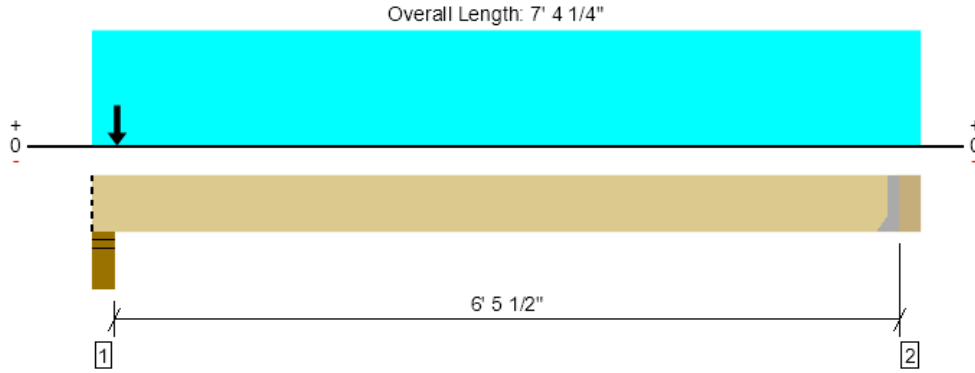

Drawing is Conceptual. All locations are measured from the outside face of left support (or left cantilever end). All dimensions are horizontal (typ.).

Design Results	Actual @ Location	Allowed	Result	LDF	Load: Combination (Pattern)
Member Reaction (lbs)	5151 @ 4"	7796 (5.50")	Passed (66%)	--	1.0 D + 0.7 E (All Spans)
Shear (lbs)	391 @ 5' 11 1/8"	8590	Passed (5%)	1.00	1.0 D + 1.0 L (All Spans)
Moment (Ft-lbs)	919 @ 3' 7 1/2"	15953	Passed (6%)	1.00	1.0 D + 1.0 L (All Spans)
Live Load Defl. (in)	0.003 @ 3' 7 1/2"	0.165	Passed (L/999+)	--	1.0 D + 0.75 L + 0.75 S (All Spans)
Total Load Defl. (in)	0.014 @ 3' 7 1/2"	0.329	Passed (L/999+)	--	1.0 D + 0.75 L + 0.75 S (All Spans)

Member Length : 6' 11"
 System : Floor
 Member Type : Flush Beam
 Building Use : Residential
 Building Code : IBC 2018
 Design Methodology : ASD

- Deflection criteria: LL (L/480) and TL (L/240).
- Allowed moment does not reflect the adjustment for the beam stability factor.
- An excessive uplift of -4322 lbs detected at support located at 4".

Supports	Bearing Length			Loads to Supports (lbs)					Accessories
	Total	Available	Required	Dead	Floor Live	Snow	Seismic	Factored	
1 - Stud wall - HF	5.50"	5.50"	3.63"	518	97	91	6618/-6618	5151/-4322	Blocking
2 - Hanger on 11 7/8" PSL beam	5.25"	Hanger ¹	1.50"	528	99	93	-	672	See note ¹

- Blocking Panels are assumed to carry no loads applied directly above them and the full load is applied to the member being designed.
- At hanger supports, the Total Bearing dimension is equal to the width of the material that is supporting the hanger
- ¹ See Connector grid below for additional information and/or requirements.

Lateral Bracing	Bracing Intervals	Comments
Top Edge (Lu)	6' 11" o/c	
Bottom Edge (Lu)	6' 11" o/c	

•Maximum allowable bracing intervals based on applied load.

Connector: Simpson Strong-Tie						
Support	Model	Seat Length	Top Fasteners	Face Fasteners	Member Fasteners	Accessories
2 - Face Mount Hanger	HU412	2.50"	N/A	16-10dx1.5	6-10d	

- Refer to manufacturer notes and instructions for proper installation and use of all connectors.

Vertical Loads	Location (Side)	Tributary Width	Dead (0.90)	Floor Live (1.00)	Snow (1.15)	Seismic (1.60)	Comments
0 - Self Weight (PLF)	0 to 6' 11"	N/A	13.0	--	--	--	
1 - Uniform (PSF)	0 to 7' 4 1/4" (Front)	8"	15.0	40.0	-	-	Upper Floor
2 - Uniform (PLF)	0 to 7' 4 1/4" (Front)	N/A	105.0	-	-	-	Wall
3 - Uniform (PSF)	0 to 7' 4 1/4" (Front)	1'	15.0	-	25.0	-	Roof
4 - Point (lb)	2 3/4" (Front)	N/A	-	-	-	6618	PT Load Seismic ΩE=6618#

- Side loads are assumed to not induce cross-grain tension.

ForteWEB Software Operator	Job Notes
Mariam Soliman BTL Engineering PS (425) 814-8448 mariam.soliman@btleng.net	



Upper Floor/ Main Wall, UB-14-Connections
1 piece(s) 3 1/2" x 11 7/8" 1.55E TimberStrand® LSL

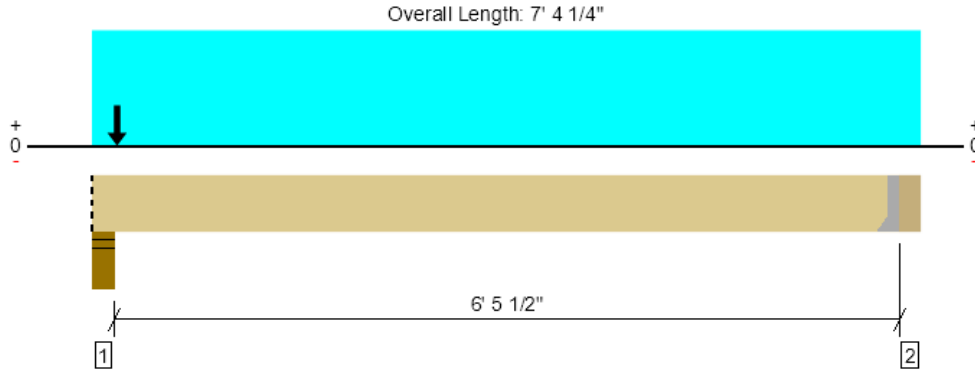

Drawing is Conceptual. All locations are measured from the outside face of left support (or left cantilever end). All dimensions are horizontal (typ.).

Design Results	Actual @ Location	Allowed	Result	LDF	Load: Combination (Pattern)
Member Reaction (lbs)	2371 @ 4"	7796 (5.50")	Passed (30%)	--	1.0 D + 0.7 E (All Spans)
Shear (lbs)	391 @ 5' 11 1/8"	8590	Passed (5%)	1.00	1.0 D + 1.0 L (All Spans)
Moment (Ft-lbs)	919 @ 3' 7 1/2"	15953	Passed (6%)	1.00	1.0 D + 1.0 L (All Spans)
Live Load Defl. (in)	0.003 @ 3' 7 1/2"	0.165	Passed (L/999+)	--	1.0 D + 0.75 L + 0.75 S (All Spans)
Total Load Defl. (in)	0.014 @ 3' 7 1/2"	0.329	Passed (L/999+)	--	1.0 D + 0.75 L + 0.75 S (All

Member Length : 6' 11"
 System : Floor
 Member Type : Flush Beam
 Building Use : Residential
 Building Code : IBC 2018
 Design Methodology : ASD

- Deflection criteria: LL (L/480) and TL (L/240).
- Allowed moment does not reflect the adjustment for the beam stability factor.
- An excessive uplift of -1542 lbs detected at support located at 4".

0.6D-0.7E
 = (0.6*518#)-(0.7*2647)
 = -1542#--> uplift resolved by Straps

Supports	Bearing Length			Loads to Supports (lbs)					Accessories
	Total	Available	Required	Dead	Floor Live	Snow	Seismic	Factored	
1 - Stud wall - HF	5.50"	5.50"	1.67"	518	97	91	2647/-2647	2371/-1542	Blocking
2 - Hanger on 11 7/8" PSL beam	5.25"	Hanger ¹	1.50"	528	99	93	-	672	See note ¹

- Blocking Panels are assumed to carry no loads applied directly above them and the full load is applied to the member being designed.
- At hanger supports, the Total Bearing dimension is equal to the width of the material that is supporting the hanger
- ¹ See Connector grid below for additional information and/or requirements.

Lateral Bracing	Bracing Intervals	Comments
Top Edge (Lu)	6' 11" o/c	
Bottom Edge (Lu)	6' 11" o/c	

•Maximum allowable bracing intervals based on applied load.

Connector: Simpson Strong-Tie						
Support	Model	Seat Length	Top Fasteners	Face Fasteners	Member Fasteners	Accessories
2 - Face Mount Hanger	HU412	2.50"	N/A	16-10dx1.5	6-10d	

• Refer to manufacturer notes and instructions for proper installation and use of all connectors.

Vertical Loads	Location (Side)	Tributary Width	Dead (0.90)	Floor Live (1.00)	Snow (1.15)	Seismic (1.60)	Comments
0 - Self Weight (PLF)	0 to 6' 11"	N/A	13.0	--	--	--	
1 - Uniform (PSF)	0 to 7' 4 1/4" (Front)	8"	15.0	40.0	-	-	Upper Floor
2 - Uniform (PLF)	0 to 7' 4 1/4" (Front)	N/A	105.0	-	-	-	Wall
3 - Uniform (PSF)	0 to 7' 4 1/4" (Front)	1'	15.0	-	25.0	-	Roof
4 - Point (lb)	2 3/4" (Front)	N/A	-	-	-	2647	PT Load Seismic E=6618#/2.5=2647#

• Side loads are assumed to not induce cross-grain tension.

Forteweb Software Operator	Job Notes
Mariam Soliman BTL Engineering PS (425) 814-8448 mariam.soliman@bt leng.net	



Shear Wall Line (A)

E = 3145 #
 W = 1915 #

D = 5542 #

$9.5 \times 10 \text{ psf} + 20.75' \times 15 \text{ psf} = 406 \text{ plf}$
 $D = 0.6 \times 406 \text{ plf} \times 22.75' = 5542 \#$

3rd Floor: 9.5' PLT

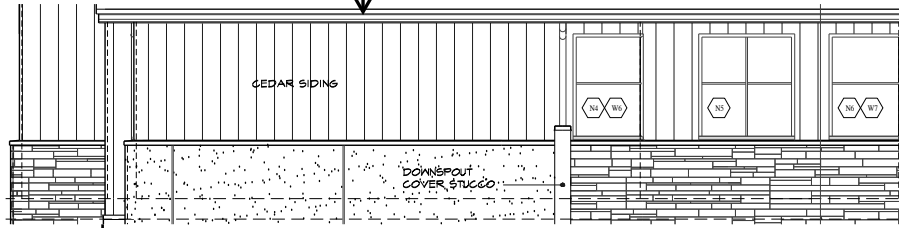

E = -1458 #
 W = -1971 #
 NO UPLIFT

E = 3145 # / 22.75' = 138 plf
 W = 1915 # / 22.75' = 84 plf

$h/b < 2, < 240\text{-plf}$

P1-6

E = 4805 #
 W = 5220 #

D = 4688 #

$10 \times 10 \text{ psf} + 9' \times 15 \text{ psf} = 235 \text{ plf}$
 $D = 0.6 \times 235 \text{ plf} \times 33.25' = 4688 \#$

2nd Floor: 10' PLT

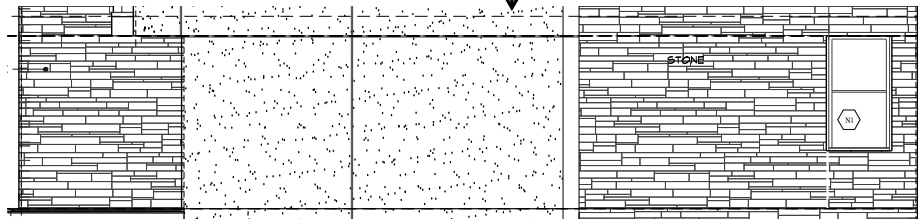

E = -890 #
 W = -774 #
 NO UPLIFT

E = 4805 # / 33.25' = 146 plf
 W = 5220 # / 33.25' = 157 plf

$h/b < 2, < 240\text{-plf}$

P1-6

E = 7285 #
 W = 8315 #

20.67'

1st Floor: 8' PLT

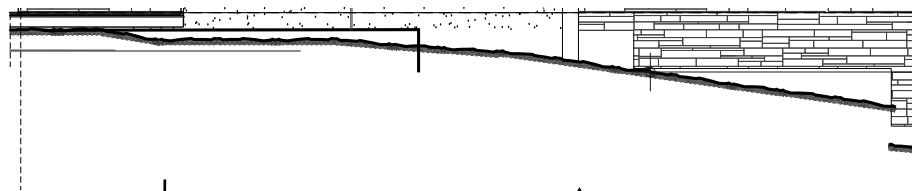

NO UPLIFT

E = 7285 # / [8" * (20.67' * 12"/1)] = 3.7 psi
 W = 8315 # / [8" * (20.67' * 12"/1)] = 4.2 psi
 $V_c = 2 * \text{sqrt}(f'_c) = 2 * \text{sqrt}(2500 \text{ psi}) = 100 \text{ psi}$
 Concrete Wall Ok

Shear Wall Line (B)

E = 3145 #
 W = 1915 #

$9.5' \times 10 \text{ pcf} + 20.75' \times 15 \text{ pcf} = 406 \text{ plf}$
 $D = 0.6 \times 406 \text{ plf} \times 12.92' = 3147 \#$

3rd Floor: 9.5' PLT

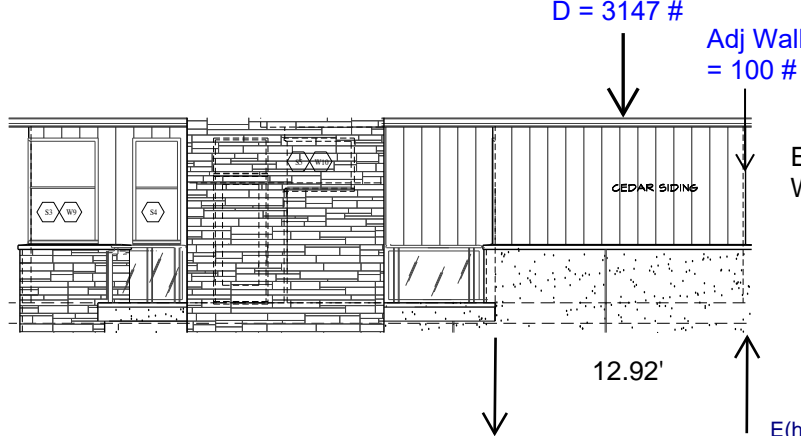

$E = 3145 \# / 12.92' = 243 \text{ plf}$
 $W = 1915 \# / 12.92' = 84 \text{ plf}$

$h/b < 2, < 240\text{-plf}$

P1-4

$E = 739 \#$
 $W = -165 \#$

CS16

$E(h/b) = 739 \times 9.5 / 12.92 = 544 \#$
 $0.7E = 544 \#$
 $\Omega E = (544 / 0.7) \times 2.5 = 1943 \#$
 on UB-13 *See L2.17

E = 4805 #
 W = 5220 #

$10' \times 10 \text{ pcf} + 6' \times 15 \text{ pcf} = 190 \text{ plf}$
 $D = 0.6 \times 190 \text{ plf} \times 7.67' = 875 \#$
 $10' \times 10 \text{ pcf} + 1' \times 15 \text{ pcf} = 115 \text{ plf}$
 $D = 0.6 \times 115 \text{ plf} \times 3.67' = 253 \#$

2nd Floor: 10' PLT

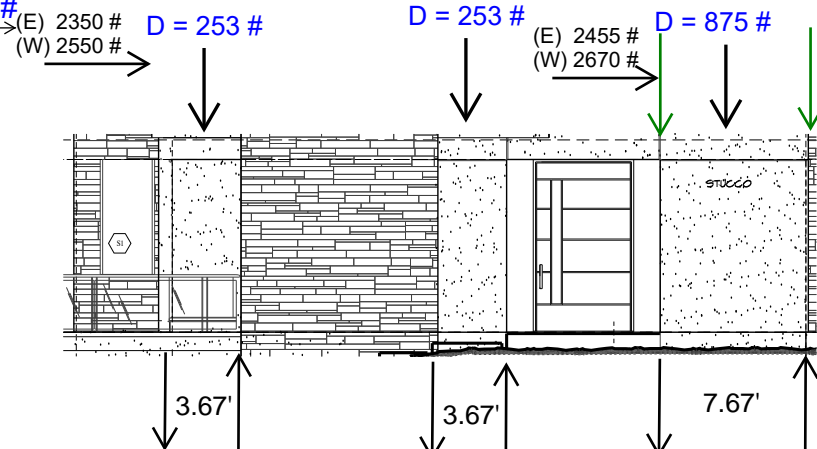

$E = 4805 \# / 15' = 320 \text{ plf}$
 $W = 5220 \# / 15' = 348 \text{ plf}$

$h/b < 2, < 350\text{-plf}$

P1-4

$E = 3075 \#$
 $W = 3347 \#$

HDU4-SDS2.5

$E = 3075 \#$
 $W = 3347 \#$

HDU4-SDS2.5

$E = 2763 \# + 739 \# = 3509 \#$
 $W = 3043 \#$

HDU4-SDS2.5

E = 7285 #
 W = 8315 #

$V_c = 2 \times \text{sqrt}(f'_c) = 2 \times \text{sqrt}(2500 \text{ psi}) = 100 \text{ psi}$
 Concrete Wall Ok

1st Floor: 8' PLT

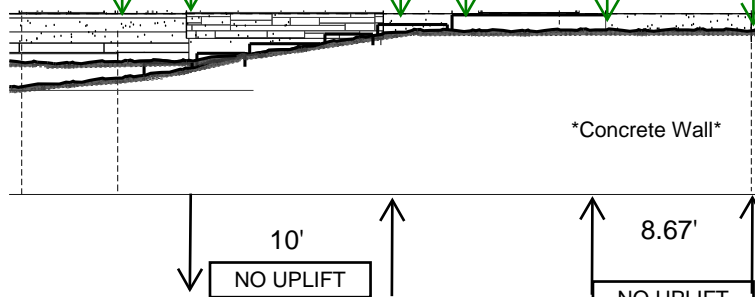

$E = 7285 \# / [8'' \times (18.67'' \times 12'' / 1)] = 4.1 \text{ psi}$
 $W = 8315 \# / [8'' \times (18.67'' \times 12'' / 1)] = 4.6 \text{ psi}$

Project: Dann Residence

Designed By: MS Date: _____

Project Number: _____ Client: _____ Scale: _____ Page: L2.16

Upper Floor/ Main Wall, UB-13 - Overstrength
1 piece(s) 3 1/2" x 9 1/2" 1.5SE TimberStrand® LSL

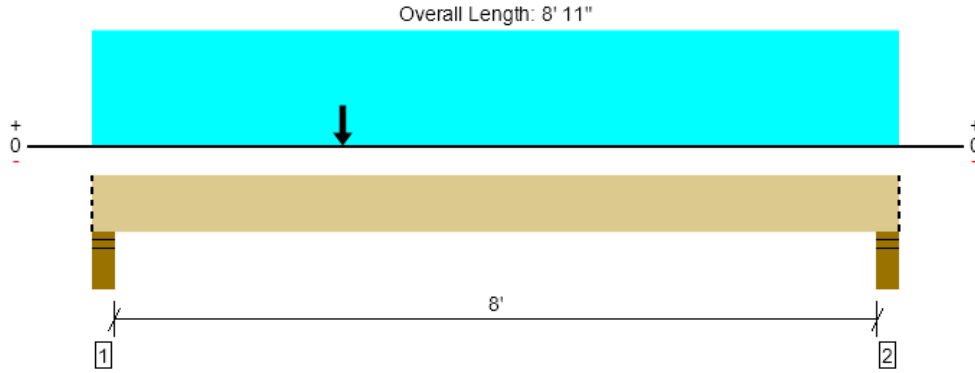

Drawing is Conceptual. All locations are measured from the outside face of left support (or left cantilever end). All dimensions are horizontal (typ.).

Design Results	Actual @ Location	Allowed	Result	LDF	Load: Combination (Pattern)
Member Reaction (lbs)	4267 @ 4"	7796 (5.50")	Passed (55%)	--	1.0 D + 0.525 E + 0.75 L + 0.75 S (All Spans)
Shear (lbs)	2842 @ 1' 3"	7902	Passed (36%)	1.15	1.0 D + 0.75 L + 0.75 S (All Spans)
Moment (Ft-lbs)	6752 @ 3' 8 3/8"	11985	Passed (56%)	1.15	1.0 D + 0.75 L + 0.75 S (All Spans)
Live Load Defl. (in)	0.123 @ 4' 3 3/4"	0.206	Passed (L/807)	--	1.0 D + 0.75 L + 0.75 S (All Spans)
Total Load Defl. (in)	0.241 @ 4' 4 1/8"	0.412	Passed (L/410)	--	1.0 D + 0.75 L + 0.75 S (All Spans)

Member Length : 8' 11"
 System : Floor
 Member Type : Flush Beam
 Building Use : Residential
 Building Code : IBC 2018
 Design Methodology : ASD

- Deflection criteria: LL (L/480) and TL (L/240).
- Allowed moment does not reflect the adjustment for the beam stability factor.

Supports	Bearing Length			Loads to Supports (lbs)					Accessories
	Total	Available	Required	Dead	Floor Live	Snow	Seismic	Factored	
1 - Stud wall - HF	5.50"	5.50"	3.01"	1743	1181	1226	1369/-1369	4267	Blocking
2 - Stud wall - HF	5.50"	5.50"	2.29"	1525	677	1226	574/-574	3253	Blocking

- Blocking Panels are assumed to carry no loads applied directly above them and the full load is applied to the member being designed.

Lateral Bracing	Bracing Intervals	Comments
Top Edge (Lu)	8' 11" o/c	
Bottom Edge (Lu)	8' 11" o/c	

- Maximum allowable bracing intervals based on applied load.

Vertical Loads	Location (Side)	Tributary Width	Dead (0.90)	Floor Live (1.00)	Snow (1.15)	Seismic (1.60)	Comments
0 - Self Weight (PLF)	0 to 8' 11"	N/A	10.4	--	--	--	
1 - Uniform (PSF)	0 to 8' 11" (Front)	1' 9"	15.0	40.0	-	-	Upper Floor
2 - Uniform (PLF)	0 to 8' 11" (Front)	N/A	105.0	-	-	-	Wall
3 - Uniform (PSF)	0 to 8' 11" (Front)	11'	15.0	-	25.0	-	Roof
4 - Point (lb)	2' 9 1/4" (Front)	N/A	533	1234	-	-	Linked from: UB-20, Support 1
5 - Point (lb)	2' 9 1/4" (Front)	N/A	-	-	-	1943	PT Load Seismic ΩE=1943#

- Side loads are assumed to not induce cross-grain tension.

Weyerhaeuser Notes

Weyerhaeuser warrants that the sizing of its products will be in accordance with Weyerhaeuser product design criteria and published design values. Weyerhaeuser expressly disclaims any other warranties related to the software. Use of this software is not intended to circumvent the need for a design professional as determined by the authority having jurisdiction. The designer of record, builder or framer is responsible to assure that this calculation is compatible with the overall project. Accessories (Rim Board, Blocking Panels and Squash Blocks) are not designed by this software. Products manufactured at Weyerhaeuser facilities are third-party certified to sustainable forestry standards. Weyerhaeuser Engineered Lumber Products have been evaluated by ICC-ES under evaluation reports ESR-1153 and ESR-1387 and/or tested in accordance with applicable ASTM standards. For current code evaluation reports, Weyerhaeuser product literature and installation details refer to www.weyerhaeuser.com/woodproducts/document-library.

The product application, input design loads, dimensions and support information have been provided by ForteWEB Software Operator

ForteWEB Software Operator	Job Notes
Mariam Soliman BTL Engineering PS (425) 814-8448 mariam.soliman@btleng.net	



10/1/2024 8:02:06 PM UTC
 ForteWEB v3.8, Engine: V8.4.1.24, Data: V8.1.6.3
 File Name: Dann Residence

Upper Floor/ Main Wall, UB-13 - Connections
1 piece(s) 3 1/2" x 9 1/2" 1.55E TimberStrand® LSL

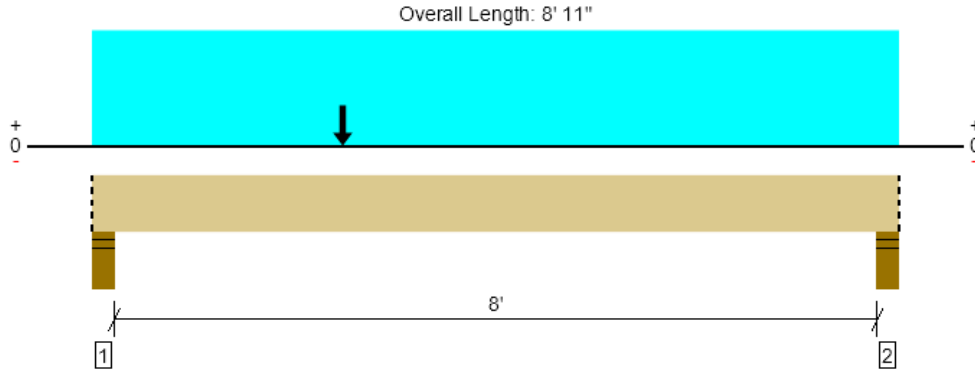

Drawing is Conceptual. All locations are measured from the outside face of left support (or left cantilever end). All dimensions are horizontal (typ.).

Design Results	Actual @ Location	Allowed	Result	LDF	Load: Combination (Pattern)
Member Reaction (lbs)	3836 @ 4"	7796 (5.50")	Passed (49%)	--	1.0 D + 0.525 E + 0.75 L + 0.75 S (All Spans)
Shear (lbs)	2842 @ 1' 3"	7902	Passed (36%)	1.15	1.0 D + 0.75 L + 0.75 S (All Spans)
Moment (Ft-lbs)	6752 @ 3' 8 3/8"	11985	Passed (56%)	1.15	1.0 D + 0.75 L + 0.75 S (All Spans)
Live Load Defl. (in)	0.123 @ 4' 3 3/4"	0.206	Passed (L/807)	--	1.0 D + 0.75 L + 0.75 S (All Spans)
Total Load Defl. (in)	0.241 @ 4' 4 1/8"	0.412	Passed (L/410)	--	1.0 D + 0.75 L + 0.75 S (All Spans)

Member Length : 8' 11"
 System : Floor
 Member Type : Flush Beam
 Building Use : Residential
 Building Code : IBC 2018
 Design Methodology : ASD

• Deflection criteria: LL (L/480) and TL (L/240).

• Allowed moment does not reflect the adjustment for the beam stability factor.

$$0.6D-0.7E = (0.6 \times 1181\#) - (0.7 \times 547) = 328\# \rightarrow \text{no uplift}$$

Supports	Bearing Length			Loads to Supports (lbs)					Accessories
	Total	Available	Required	Dead	Floor Live	Snow	Seismic	Factored	
1 - Stud wall - HF	5.50"	5.50"	2.71"	1743	1181	1226	547/-547	3836	Blocking
2 - Stud wall - HF	5.50"	5.50"	2.17"	1525	677	1226	230/-230	3072	Blocking

• Blocking Panels are assumed to carry no loads applied directly above them and the full load is applied to the member being designed.

Lateral Bracing	Bracing Intervals	Comments
Top Edge (Lu)	8' 11" o/c	
Bottom Edge (Lu)	8' 11" o/c	

•Maximum allowable bracing intervals based on applied load.

Vertical Loads	Location (Side)	Tributary Width	Dead (0.90)	Floor Live (1.00)	Snow (1.15)	Seismic (1.60)	Comments
0 - Self Weight (PLF)	0 to 8' 11"	N/A	10.4	--	--	--	
1 - Uniform (PSF)	0 to 8' 11" (Front)	1' 9"	15.0	40.0	-	-	Upper Floor
2 - Uniform (PLF)	0 to 8' 11" (Front)	N/A	105.0	-	-	-	Wall
3 - Uniform (PSF)	0 to 8' 11" (Front)	11'	15.0	-	25.0	-	Roof
4 - Point (lb)	2' 9 1/4" (Front)	N/A	533	1234	-	-	Linked from: UB-20, Support 1
5 - Point (lb)	2' 9 1/4" (Front)	N/A	-	-	-	777	PT Load Seismic E=1943#/2.5=777 #

• Side loads are assumed to not induce cross-grain tension.

Weyerhaeuser Notes

Weyerhaeuser warrants that the sizing of its products will be in accordance with Weyerhaeuser product design criteria and published design values. Weyerhaeuser expressly disclaims any other warranties related to the software. Use of this software is not intended to circumvent the need for a design professional as determined by the authority having jurisdiction. The designer of record, builder or framer is responsible to assure that this calculation is compatible with the overall project. Accessories (Rim Board, Blocking Panels and Squash Blocks) are not designed by this software. Products manufactured at Weyerhaeuser facilities are third-party certified to sustainable forestry standards. Weyerhaeuser Engineered Lumber Products have been evaluated by ICC-ES under evaluation reports ESR-1153 and ESR-1387 and/or tested in accordance with applicable ASTM standards. For current code evaluation reports, Weyerhaeuser product literature and installation details refer to www.weyerhaeuser.com/woodproducts/document-library.

The product application, input design loads, dimensions and support information have been provided by ForteWEB Software Operator

ForteWEB Software Operator	Job Notes
Mariam Soliman BTL Engineering PS (425) 814-8448 mariam.soliman@btleng.net	



10/1/2024 8:02:21 PM UTC
 ForteWEB v3.8, Engine: V8.4.1.24, Data: V8.1.6.3
 File Name: Dann Residence

BTL

ENGINEERING

19011 Wood-Sno Road NE, Suite 100

Woodinville, WA 98072-4436

Phone: (425) 814-8448

Fax: (425) 821-2120

Lateral
Shear Wall/Diaphragm Capacities

2018 IBC/SDPWS 2015 – Diaphragms (8d Nailing)

Table 4.2C Nominal Unit Shear Capacities for Wood-Frame Diaphragms

Unblocked Wood Structural Panel Diaphragms^{1,2,3,4,5}

Sheathing Grade	Common Nail Size	Minimum Fastener Penetration in Framing (in.)	Minimum Nominal Panel Thickness (in.)	Minimum Nominal Width of Nailed Face at Supported Edges and Boundaries (in.)	A SEISMIC				B WIND	
					6 in. Nail Spacing at diaphragm boundaries and supported panel edges				6 in. Nail Spacing at diaphragm boundaries and supported panel edges	
					Case 1		Cases 2,3,4,5,6		Case 1	Cases 2,3,4,5,6
V_n (plf)	G_n (kips/in.)	V_n (plf)	G_n (kips/in.)	V_n (plf)	V_n (plf)					
Structural I	6d	1-1/4	5/16	2	OSB	PLY	OSB	PLY	460	350
					370	7.0	6.0	280	4.5	4.0
					480	8.5	7.0	360	6.0	4.5
	8d	1-3/8	3/8	2	530	7.5	6.0	400	5.0	4.0
					570	14	10	430	9.5	7.0
					640	12	9.0	480	8.0	6.0
10d	1-1/2	15/32	2	300	9.0	6.5	220	6.0	4.0	
				340	7.0	5.5	250	5.0	3.5	
				330	7.5	5.5	250	5.0	4.0	
Sheathing and Single-Floor	8d	1-3/8	7/16	2	370	6.0	4.5	280	4.0	3.0
					480	7.5	5.5	360	5.0	3.5
					510	7.0	5.5	380	4.5	3.5
	10d	1-1/2	15/32	2	480	7.5	5.5	360	5.0	4.0
					530	8.5	6.0	420	4.0	3.5
					510	15	9.0	380	10	6.0
10d	1-1/2	19/32	2	580	12	8.0	430	8.0	5.5	
				570	13	8.5	430	8.5	5.5	
				640	10	7.5	480	7.0	5.0	

- Nominal unit shear capacities shall be adjusted in accordance with 4.2.3 to determine ASD allowable unit shear capacity and LRFD factored unit resistance. For general construction requirements see 4.2.6. For specific requirements, see 4.2.7.1 for wood structural panel diaphragms. See Appendix A for common nail dimensions.
- For species and grades of framing other than Douglas-Fir-Larch or Southern Pine, reduced nominal unit shear capacities shall be determined by multiplying the tabulated nominal unit shear capacity by the Specific Gravity Adjustment Factor = $[1 - (0.5 - G)]$, where G = Specific Gravity of the framing lumber from the NDS (Table 12.3.3.A). The Specific Gravity Adjustment Factor shall not be greater than 1.
- Apparent shear stiffness values, G_n , are based on nail slip in framing with moisture content less than or equal to 19% at time of fabrication and panel stiffness values for diaphragms constructed with either OSB or 3-ply plywood panels. When 4-ply or 5-ply plywood panels or composite panels are used, G_n values shall be permitted to be multiplied by 1.2.
- Where moisture content of the framing is greater than 19% at time of fabrication, G_n values shall be multiplied by 0.5.
- Diaphragm resistance depends on the direction of continuous panel joints with respect to the loading direction and direction of framing members, and is independent of the panel orientation.

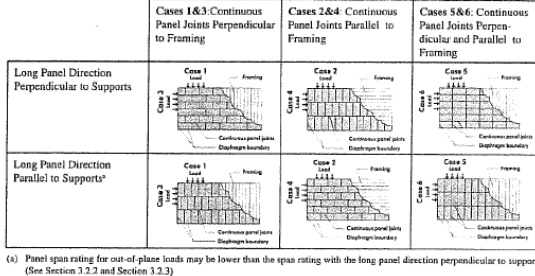
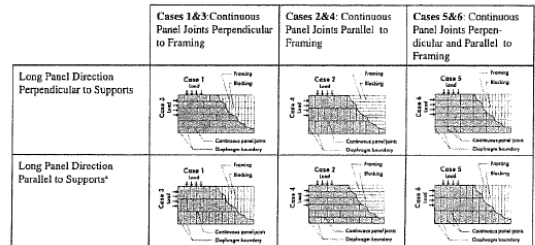

Table 4.2A Nominal Unit Shear Capacities for Wood-Frame Diaphragms

Unblocked Wood Structural Panel Diaphragms^{1,2,3,4,5}

Sheathing Grade	Common Nail Size	Minimum Fastener Penetration in Framing Member or Blocking (in.)	Minimum Nominal Panel Thickness (in.)	Minimum Nominal Width of Nailed Face at Adjoining Panel Edges and Boundaries (in.)	A SEISMIC						B WIND									
					Nail Spacing (in.) at diaphragm boundaries (all cases), at continuous panel edges parallel to load (Cases 3 & 4), and at all panel edges (Cases 5 & 6)						Nail Spacing (in.) at diaphragm boundaries (all cases), at continuous panel edges parallel to load (Cases 3 & 4), and at all panel edges (Cases 5 & 6)									
					6		4		2-1/2		2		6		4		2-1/2		2	
V_n (plf)	G_n (kips/in.)	V_n (plf)	G_n (kips/in.)	V_n (plf)	G_n (kips/in.)	V_n (plf)	G_n (kips/in.)	V_n (plf)	G_n (kips/in.)	V_n (plf)	G_n (kips/in.)	V_n (plf)	G_n (kips/in.)	V_n (plf)	G_n (kips/in.)					
Structural I	6d	1-1/4	5/16	2	OSB	PLY	OSB	PLY	OSB	PLY	OSB	PLY	OSB	PLY	OSB	PLY				
					370	15	12	500	8.5	7.5	750	12	10	840	20	15	520	700	1050	1175
					420	12	9.5	560	7.0	6.0	840	9.5	8.5	950	17	13	590	785	1175	1330
	8d	1-3/8	3/8	2	540	14	11	720	9.0	7.5	1050	13	10	1260	21	15	755	1010	1485	1680
					600	12	10	800	7.5	6.5	1200	10	9.0	1350	18	13	840	1120	1680	1890
					640	24	17	850	15	12	1280	20	15	1460	31	21	895	1190	1790	2045
10d	1-1/2	15/32	2	720	20	15	960	12	9.5	1440	18	13	1640	26	18	1010	1345	2015	2295	
				340	15	10	450	9.0	7.0	670	13	9.5	760	21	13	475	630	940	1085	
				369	12	9.0	500	7.0	6.0	760	10	8.0	850	17	12	530	700	1050	1205	
Sheathing and Single-Floor	8d	1-3/8	7/16	2	370	13	9.5	500	7.0	6.0	750	10	8.0	840	18	12	520	700	1050	1175
					420	10	8.0	560	5.5	5.0	840	8.5	7.0	950	14	10	590	785	1175	1330
					480	15	11	640	9.5	7.5	960	13	9.5	1080	21	13	670	895	1345	1525
	10d	1-1/2	15/32	2	240	12	9.5	720	7.5	6.0	1080	11	8.5	1220	18	12	755	1010	1510	1710
					510	14	10	680	9.5	7.0	1010	12	9.5	1150	20	13	715	950	1415	1610
					570	11	9.0	760	7.0	6.0	1140	10	8.0	1290	17	12	800	1055	1585	1805
10d	1-1/2	19/32	2	540	13	9.5	720	7.5	6.5	1060	11	8.5	1200	19	13	755	1010	1485	1680	
				600	10	8.5	850	6.0	5.5	1200	9.0	7.5	1350	15	11	840	1120	1680	1890	
				650	25	15	770	15	11	1150	21	14	1310	33	18	910	1190	1610	1810	
10d	1-1/2	19/32	2	650	21	14	860	12	9.5	1300	17	12	1470	28	16	910	1205	1820	2040	
				640	21	14	860	13	9.5	1280	18	12	1460	28	17	895	1190	1790	2045	
				720	17	12	960	10	8.0	1440	14	11	1640	24	15	1010	1345	2015	2295	

- Nominal unit shear capacities shall be adjusted in accordance with 4.2.3 to determine ASD allowable unit shear capacity and LRFD factored unit resistance. For general construction requirements see 4.2.6. For specific requirements, see 4.2.7.1 for wood structural panel diaphragms. See Appendix A for common nail dimensions.
- For species and grades of framing other than Douglas-Fir-Larch or Southern Pine, reduced nominal unit shear capacities shall be determined by multiplying the tabulated nominal unit shear capacity by the Specific Gravity Adjustment Factor = $[1 - (0.5 - G)]$, where G = Specific Gravity of the framing lumber from the NDS (Table 12.3.3.A). The Specific Gravity Adjustment Factor shall not be greater than 1.
- Apparent shear stiffness values, G_n , are based on nail slip in framing with moisture content less than or equal to 19% at time of fabrication and panel stiffness values for diaphragms constructed with either OSB or 3-ply plywood panels. When 4-ply or 5-ply plywood panels or composite panels are used, G_n values shall be permitted to be multiplied by 1.2.
- Where moisture content of the framing is greater than 19% at time of fabrication, G_n values shall be multiplied by 0.5.
- Diaphragm resistance depends on the direction of continuous panel joints with respect to the loading direction and direction of framing members, and is independent of the panel orientation.



- Reduction Factor = 2
- $G = 0.42$ (SPF or Hem Fir)... Adjustment Factor = $[1 - (0.5 - 0.42)] = 0.92$ or 0.5 (I-Joists or Douglas Fir)... Adjustment Factor = 1.0

Diaphragm	Sheathing Thickness	Nail Spacing Edge/Intermediate	Blocked	Framing	Seismic Capacity (Case 1/Other)	Wind Capacity (Case 1/Other)
Roof – Unblocked	7/16"	6"/12" oc	N	2x (SPF/HF)	212-plf/156-plf	297-plf/219-plf
Roof – Blocked	7/16"	4"/12" oc	Y	2x (SPF/HF)	313-plf	437-plf
Floor – Unblocked	3/4"	6"/12" oc	N	2x (DF) or 3x (HF)	240-plf/180-plf	335-plf/252-plf
Floor – Blocked	3/4"	4"/12" oc,	Y	2x (DF) or 3x (HF)	360-plf	505-plf

2018 IBC/SDPWS 2015 – Shear Wall Schedule

7/16" OSB; 0.131" φ Nails; SPF or HF Studs @ 16" oc

Table 4.3A Nominal Unit Shear Capacities for Wood-Frame Shear Walls^{1,3,6,7}

Wood-based Panels ⁴																			
Sheathing Material	Minimum Nominal Panel Thickness (in.)	Minimum Fastener Penetration in Framing Member or Blocking (in.)	Fastener Type & Size	A SEISMIC								B WIND							
				Panel Edge Fastener Spacing (in.)								Panel Edge Fastener Spacing (in.)							
				6		4		3		2		6		4		3			
				v_s (plf)	G_s (kips/in.)	v_s (plf)	G_s (kips/in.)	v_s (plf)	G_s (kips/in.)	v_s (plf)	G_s (kips/in.)	v_w (plf)	v_w (plf)	v_w (plf)	v_w (plf)				
Wood Structural Panels - Structural I ^{1,5}	5/16	1-1/4	Nail (common or galvanized box) 6d	400	13	10	600	18	13	780	23	16	1020	35	22	580	840	1090	1430
	3/8	1-3/8	8d	460	19	14	720	24	17	920	30	20	1220	43	24	645	1010	1290	1710
	7/16			510	16	13	790	21	16	1010	27	19	1340	40	24	715	1105	1415	1875
	15/32			560	14	11	860	18	14	1100	24	17	1460	37	23	785	1205	1540	2045
	15/32	1-1/2	10d	680	22	16	1020	29	20	1330	36	22	1740	51	28	950	1430	1860	2435
Wood Structural Panels - Sheathing ^{1,5}	5/16	1-1/4	6d	360	13	9.5	540	18	12	700	24	14	900	37	18	505	755	980	1260
	3/8			400	11	8.5	600	15	11	780	20	13	1020	32	17	560	840	1090	1430
	7/16	1-3/8	8d	440	17	12	640	25	15	820	31	17	1060	45	20	615	895	1150	1485
	15/32			480	15	11	700	22	14	900	28	17	1170	42	21	670	980	1260	1640
	15/32	1-1/2	10d	520	13	10	760	19	13	960	25	15	1260	39	20	730	1065	1370	1790
	19/32			620	22	14	920	30	17	1200	37	19	1540	52	23	870	1290	1680	2165
	19/32	1-1/2	10d	680	19	13	1020	26	16	1330	33	18	1740	48	22	950	1430	1860	2435
Plywood Siding	5/16	1-1/4	Nail (galvanized casing) 6d	280	13		420	16		550	17		720	21		390	590	770	1010
	3/8	1-3/8	8d	320	16		480	18		620	20		820	22		450	670	870	1150
Particleboard Sheathing - (M-S "Exterior Glue" and M-2 "Exterior Glue")	3/8		Nail (common or galvanized box) 6d	240	15		360	17		460	19		600	22		335	505	645	840
	3/8		8d	260	18		380	20		480	21		630	23		365	530	670	880
	1/2			280	16		420	20		540	22		700	24		390	590	755	980
	1/2		10d	370	21		550	23		720	24		920	25		520	770	1010	1290
	5/8			400	21		610	23		790	24		1040	26		560	855	1105	1455
Structural Fiberboard Sheathing	1/2		Nail (galvanized roofing) 11 ga. galv. roofing nail (0.120" x 1-1/2" long x 7/16" head)				340	4.0		460	5.0		520	5.5			475	645	730
	25/32		11 ga. galv. roofing nail (0.120" x 1-3/4" long x 3/8" head)				340	4.0		460	5.0		520	5.5			475	645	730

- Nominal unit shear capacities shall be adjusted in accordance with 4.3.3 to determine ASD allowable unit shear capacity and LRFD factored unit resistance. For general construction requirements see 4.3.6. For specific requirements, see 4.3.7.1 for wood structural panel shear walls, 4.3.7.2 for particleboard shear walls, and 4.3.7.3 for fiberboard shear walls. See Appendix A for common and box nail dimensions.
- Shears are permitted to be increased to values shown for 15/32 inch (nominal) sheathing with same nailing provided (a) studs are spaced a maximum of 16 inches on center, or (b) panels are applied with long dimension across studs.
- For species and grades of framing other than Douglas-Fir-Larch or Southern Pine, reduced nominal unit shear capacities shall be determined by multiplying the tabulated nominal unit shear capacity by the Specific Gravity Adjustment Factor = $[1 - (0.5 - G)]$, where G = Specific Gravity of the framing lumber from the NDS (Table 12.3.3A). The Specific Gravity Adjustment Factor shall not be greater than 1.
- Apparent shear stiffness values G_s are based on nail slip in framing with moisture content less than or equal to 19% at time of fabrication and panel stiffness values for shear walls constructed with either OSB or 3-ply plywood panels. When 4-ply or 5-ply plywood panels or composite panels are used, G_s values shall be permitted to be multiplied by 1.2.
- Where moisture content of the framing is greater than 19% at time of fabrication, G_s values shall be multiplied by 0.5.
- Where panels are applied on both faces of a shear wall and nail spacing is less than 6" on center on either side, panel joints shall be offset to fall on different framing members as shown below. Alternatively, the width of the nailed face of framing members shall be 3" nominal or greater at adjoining panel edges and nails at all panel edges shall be staggered.
- Galvanized nails shall be hot-dipped or tumbled.

- Reduction Factor = 2
- 16" oc studs – use values for 15/32
- $G = 0.42$ (SPF or Hem Fir)... Adjustment Factor = $[1 - (0.5 - 0.42)] = 0.92$

Wall Type	Blocked	Sheathing (1) or (2) Sides	Nail Spacing Edge/Intermediate	Framing	Sill Plate	Seismic Capacity $h/b_s = 2$	Seismic Capacity $h/b_s = 3.5$	Wind Capacity $h/b_s = 2$	Wind Capacity $h/b_s = 3.5$
P1-6	Y	1	6"/12" oc	2x	2x	240-plf	194-plf	335-plf	272-plf
P1-4	Y	1	4"/12" oc	2x	2x	350-plf	284-plf	490-plf	398-plf
P1-3	Y	1	3"/12" oc	2-2x	2x	450-plf	366-plf	630-plf	512-plf
P1-2	Y	1	2"/12" oc	2-2x	2x	590-plf	478-plf	820-plf	669-plf
P2-4	Y	2	4"/12" oc, ea. side	2-2x	3x	700-plf	568-plf	980-plf	796-plf
P2-3	Y	2	3"/12" oc, ea. side	2-2x	3x	900-plf	733-plf	1260-plf	1024-plf
P2-2	Y	2	2"/12" oc, ea. side	2-2x	3x	1180-plf	957-plf	1640-plf	1338-plf

2018 IBC/NDS 2015 – Shear Wall Framing Clips

Model No.	Type of Connection	Fasteners (in.)	Direction of Load	DF/SP Allowable Loads			SPF/HF Allowable Loads		
				Floor (100)	Roof (125)	(160)	Floor (100)	Roof (125)	(160)
SS A34	1	(8) 0.131 x 1 1/2	F ₁	395	465	465	340	400	400
			F ₂ ⁶	395	430	430	340	370	370
	1	(8) #9 x 1 1/2 SD	F ₁	640	640	640	550	550	550
			F ₂	495	495	495	425	425	425
			Uplift	240	240	240	170	170	170
SS A35	2	(9) 0.131 x 1 1/2	A ₁	295	350	350	255	300	300
			E	295	360	385	255	310	330
			C ₁	185	185	185	160	160	160
	3	(12) 0.131 x 1 1/2	A ₂	295	325	325	255	280	280
			C ₂	295	330	330	255	285	285
			D	225	225	225	195	195	195
	4	(12) 0.131 x 1 1/2	F ₁	590	650	650	510	560	560
			F ₂ ⁶	590	670	670	510	575	575
	5	(12) PH612I	F ₁	420	420	420	360	360	360
	LTP4	6	(12) 0.131 x 1 1/2	G	580	625	625	500	540
H				580	525	525	500	450	450
LTP5	7	(12) 0.131 x 1 1/2	G	580	565	565	500	485	485
			H	545	490	490	470	420	420

- Allowable loads are for one angle. When angles are installed on each side of the joist, the minimum joist thickness is 3".
- Some illustrations show connections that could cause cross-grain tension or bending of the wood during loading if not reinforced sufficiently. In this case, mechanical reinforcement should be considered.
- LTP4 can be installed over 3/8" wood structural panel sheathing with 0.131" x 1 1/2" nails and achieve 0.72 of the listed load, or over 1/2" sheathing and achieve 0.64 of the listed load. 0.131" x 2 1/2" nails will achieve 100% load.
- LTP4 satisfies the IRC continuously sheathed portal frame (CS-PF) framing anchor requirements when installed over raised wood floor framing per Figure R602.10.6.4.
- The LTP5 may be installed over wood structural panel sheathing up to 1/2" thick using 0.131" x 1 1/2" nails with no reduction in load.
- Connectors are required on both sides to achieve F₂ loads in both directions.
- Fasteners: Nail dimensions in the table are diameter by length. SD screws are Simpson Strong-Tie® Strong-Drive® screws. PH612I is a pan-head #6 x 1/2" screw available from Simpson Strong-Tie. For additional information, see [Fastener Types and Sizes Specified for Simpson Strong-Tie Connectors](#).

Wall Type	Capacity	A35 Capacity	A35 Spacing	LTP4 Capacity	LTP4 Spacing
P1-6U	144-plf (E)	560#	44" oc	540#	44" oc
P1-6	240-plf (E)	560#	27" oc	540#	27" oc
P1-4	350-plf (E)	560#	18" oc	540#	18" oc
P1-3	450-plf (E)	560#	14" oc	540#	14" oc
P1-2	820-plf (W)	560#	7 1/2" oc	540#	7 1/2" oc
P2-4	700-plf (E)	560#	9" oc	540#	LTP5 18" oc + A35 18" oc
P2-3	900-plf (E)	560#	7" oc	540#	LTP5 14" oc + A35 14" oc
P2-2	1640-plf (W)	560#	2 rows 8" oc	540#	LTP5 8" oc + A35 8" oc

2018 IBC/NDS 2018 – Shear Wall Bolts

Table 12E BOLTS: Reference Lateral Design Values, Z, for Single Shear (two member) Connections^{1,2,3,4}

for sawn lumber or SCL to concrete

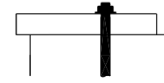

Embedment Depth in Concrete	Thickness	Side Member	Bolt Diameter	G=0.43 Hem-Fir		G=0.42 Spruce-Pine-Fir		G=0.37 Redwood (open grain)		G=0.36 Eastern Softwoods Spruce-Pine-Fir (S) Western Cedars Western Woods		G=0.35 Northern Species		
				$Z_{ }$	Z_{\perp}	$Z_{ }$	Z_{\perp}	$Z_{ }$	Z_{\perp}	$Z_{ }$	Z_{\perp}	$Z_{ }$	Z_{\perp}	
				lbs.	lbs.	lbs.	lbs.	lbs.	lbs.	lbs.	lbs.	lbs.	lbs.	
6.0 and greater	1-1/2	1/2	1/2	590	340	590	340	550	310	540	290	530	290	
			5/8	860	420	850	410	810	350	800	330	780	320	
			3/4	1200	460	1190	450	1130	370	1120	360	1100	350	
			7/8	1580	500	1540	490	1360	410	1330	390	1280	370	
			1	1800	540	1760	530	1560	440	1520	420	1460	410	
			1-3/4	1/2	640	360	630	350	580	320	580	310	560	310
				5/8	910	490	900	480	840	400	830	380	810	370
				3/4	1230	540	1220	530	1160	430	1140	420	1120	410
				7/8	1630	580	1610	570	1540	470	1520	460	1490	430
				1	2090	630	2060	610	1820	510	1770	490	1710	470
				2-1/2	1/2	730	410	730	400	700	360	690	340	680
			5/8		1070	540	1060	530	980	480	960	470	940	460
	3/4	1400	710		1380	700	1290	620	1270	600	1240	580		
	7/8	1790	830		1770	810	1660	680	1640	660	1600	610		
	1	2230	900		2210	880	2080	730	2060	700	2030	680		
	3-1/2	1/2	730		470	730	470	700	430	690	410	690	400	
		5/8	1140	620	1140	610	1090	550	1080	530	1070	520		
		3/4	1650	780	1640	770	1540	680	1510	670	1470	660		
		7/8	2100	960	2070	950	1910	870	1880	850	1840	820		
		1	2550	1190	2520	1180	2340	1020	2310	980	2260	950		

1. Tabulated lateral design values, Z, for bolted connections shall be multiplied by all applicable adjustment factors (see Table 11.3.1).
2. Tabulated lateral design values, Z, are for "full-body diameter" bolts (see Appendix Table L1) with bolt bending yield strength, F_{yb} , of 45,000 psi.
3. Tabulated lateral design values, Z, are based on dowel bearing strength, F_{bc} , of 7,500 psi for concrete with minimum $f'_c=2,500$ psi.
4. Six inch anchor embedment assumed.

Model No.	Sill Size	Fasteners (in.)		Allowable Loads											
		Sides	Top	Uncracked						Cracked					
				Wind and SDC A&B ^{5,6}		SDC C-F ⁵		Wind and SDC A&B ^{5,6}		SDC C-F ⁵					
				Uplift	F ₁	F ₂	Uplift	F ₁	F ₂	Uplift	F ₁	F ₂	Uplift	F ₁	F ₂
Standard Installation – Attached to DF/SP Sill Plate															
MASA or MASAP	2x4, x6, x8, x10	(3) 0.148 x 1 1/2	(6) 0.148 x 1 1/2	920	1,475	1,095	745	1,235	1,045	750	1,475	875	660	1,235	765
	3x4, 3x6	(5) 0.148 x 1 1/2	(4) 0.148 x 1 1/2	630	1,165	725	550	1,020	725	475	1,165	725	415	1,020	640
One-Leg-Up Installation – Attached to DF/SP Sill Plate															
MASA or MASAP	2x4, x6, x8, x10	(6) 0.148 x 1 1/2	(3) 0.148 x 1 1/2	755	965	995	660	845	995	570	965	930	500	845	810
	3x4, 3x6	(7) 0.148 x 1 1/2	(2) 0.148 x 1 1/2	—	760	—	—	685	—	—	760	—	—	685	—
Two-Legs-Up Installation – Attached to DF/SP Sill Plate and Rimboard															
MASA or MASAP	2x4, x6, x8, x10	(9) 0.148 x 1 1/2	—	810	1,105	865	740	965	755	620	1,105	630	560	965	550
Double 2x Installation – Attached to DF/SP Sill Plate															
MASA or MASAP	Double 2x4, Double 2x6	(5) 0.148 x 1 1/2	(2) 0.148 x 1 1/2	840	1,030	785	735	900	785	635	1,030	785	555	900	785
Standard Installation – Attached to Hem Fir Sill Plate															
MASA or MASAP	2x4, x6, x8, x10	(3) 0.148 x 1 1/2	(6) 0.148 x 1 1/2	790	1,250	940	640	1,060	900	650	1,250	755	570	1,060	660
	3x4, 3x6	(5) 0.148 x 1 1/2	(4) 0.148 x 1 1/2	535	1,005	625	475	875	625	410	1,005	625	355	875	550
One-Leg-Up Installation – Attached to Hem Fir Sill Plate and HF/SP Stud															
MASA or MASAP	2x4, x6, x8, x10	(6) 0.148 x 1 1/2	(3) 0.148 x 1 1/2	650	830	855	565	725	855	490	830	795	430	725	695
	3x4, 3x6	(7) 0.148 x 1 1/2	(2) 0.148 x 1 1/2	—	670	—	—	590	—	—	670	—	—	590	—
Two-Legs-Up Installation – Hem Fir Sill Plate and HF/SP Rimboard															
MASA or MASAP	2x4, x6, x8, x10	(9) 0.148 x 1 1/2	—	700	950	745	635	830	650	545	950	540	480	830	475
Double 2x Installation – Attached to Hem Fir Sill Plate															
MASA or MASAP	Double 2x4, Double 2x6	(5) 0.148 x 1 1/2	(2) 0.148 x 1 1/2	720	890	675	630	775	675	545	890	675	555	775	675

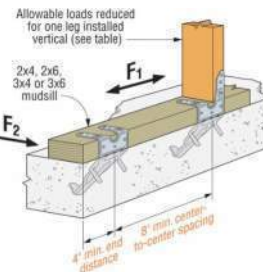

Wall Type	Capacity	Sill Plate	Single 5/8" φ Bolt Capacity	5/8" φ Anchor Bolt Spacing	MASAP Anchor Capacity	MASAP Anchor Spacing
P1-6U	144-plf (E)	2x	1376#	60" oc	1060#	60" oc
P1-6	240-plf (E)	2x	1376#	60" oc	1060#	52" oc
P1-4	350-plf (E)	2x	1376#	46" oc	1060#	36" oc
P1-3	450-plf (E)	2x	1376#	36" oc	1060#	28" oc
P1-2	820-plf (W)	2x	1376#	20" oc	1250#	18" oc
P2-4	700-plf (E)	3x	1712#	28" oc	875#	15" oc
P2-3	900-plf (E)	3x	1712#	22" oc	875#	11" oc
P2-2	1640-plf (W)	3x	1712#	12" oc	1005#	7" oc

SHEAR WALL SCHEDULE

(IN ACCORDANCE w/ ANSI/AF&PA SDPWS-2015 SECTION 4.3)
Updated 1/20/2021

WALL TYPE	SHEATHING	PANEL EDGE NAILING ②	MINIMUM WIDTH OF NAILED FACE OF FRAMING @ ADJOINING PANEL EDGES ③		MUDSILL PLATE	FACE NAILING ④	FRAMING CLIPS ⑤	ANCHORAGE TO CONCRETE ⑥		SEISMIC CAPACITY - h/b = 2 h/b = 3.5	WIND CAPACITY - h/b = 2 h/b = 3.5
			SINGLE MEMBER	BUILT-UP MEMBER				ANCHOR BOLTS	MUDSILL ANCHORS		
P1-6	1 SIDE	6" oc	2x	2x	2x	6" oc	A35 @ 27" oc or LTP4 @ 27" oc	5/8"Ø @ 60" oc	MASAP @ 52" oc	240-plf 194-plf	240-plf 194-plf
P1-4	1 SIDE	4" oc	2x	2x	2x	4" oc	A35 @ 18" oc or LTP4 @ 18" oc	5/8"Ø @ 46" oc	MASAP @ 36" oc	350-plf 284-plf	350-plf 284-plf
P1-3	1 SIDE	3" oc	3x	(2)2x	2x	3" oc	A35 @ 14" oc or LTP4 @ 14" oc	5/8"Ø @ 36" oc	MASAP @ 28" oc	450-plf 366-plf	450-plf 366-plf
P1-2	1 SIDE	2" oc	3x	(2)2x	2x	2" oc	A35 @ 11" oc or LTP4 @ 11" oc	5/8"Ø @ 20" oc	MASAP @ 18" oc	590-plf 478-plf	820-plf 669-plf
P2-4	2 SIDES	4" oc	3x	(2)2x	3x	(2) Rows, 4" oc	A35 @ 18" oc and LTP4 @ 18" oc	5/8"Ø @ 28" oc	MASAP @ 15" oc	700-plf 568-plf	700-plf 568-plf
P2-3	2 SIDES	3" oc	3x	(2)2x	3x	(2) Rows, 3" oc	A35 @ 14" oc and LTP4 @ 14" oc	5/8"Ø @ 22" oc	MASAP @ 11" oc	900-plf 733-plf	900-plf 733-plf
P2-2	2 SIDES	2" oc	3x	(2)2x	3x	(2) Rows, 2" oc	A35 @ 8" oc and LTP4 @ 8" oc	5/8"Ø @ 12" oc	MASAP @ 7" oc	1180-plf 957-plf	1640-plf 1338-plf

SHEAR WALL SCHEDULE NOTES

- (SECTION 4.3.7.1.1)
5/8" OSB or 5/8" PLYWOOD SHEATHING OR SIDING EXCEPT GROUP 5 SPECIES. MINIMUM PANEL SPAN RATING OF (24/0). PANELS SHALL NOT BE LESS THAN 4x8', EXCEPT AT BOUNDARIES AND CHANGES IN FRAMING. ALL EDGES OF ALL PANELS SHALL BE SUPPORTED BY AND FASTENED TO FRAMING MEMBERS OR BLOCKING.
- ② (SECTION 4.3.7.1.2. & SECTION 4.3.7.1.3)
PANEL EDGE NAILING APPLIES TO ALL SHEATHING PANEL EDGES. NAIL SHEATHING TO INTERMEDIATE FRAMING MEMBERS WITH SHEATHING NAILS @ 12" oc. MAXIMUM STUD SPACING SHALL BE 16" oc. SHEATHING NAILS SHALL BE 0.131"Ø x 2 1/2". PLYWOOD EDGE NAILING SHALL BE STAGGERED. NAILS SHALL BE LOCATED AT LEAST 1/4" FROM THE PANEL EDGES.

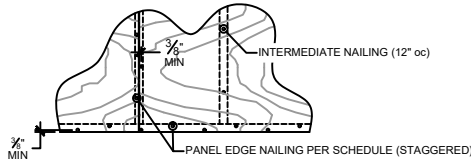

- ③ (SECTION 4.3.7.1.4)
THE MINIMUM NOMINAL WIDTH OF THE NAILED FACE OF FRAMING AND BLOCKING AT ADJOINING PANEL EDGES SHALL BE AS INDICATED IN THE SCHEDULE.

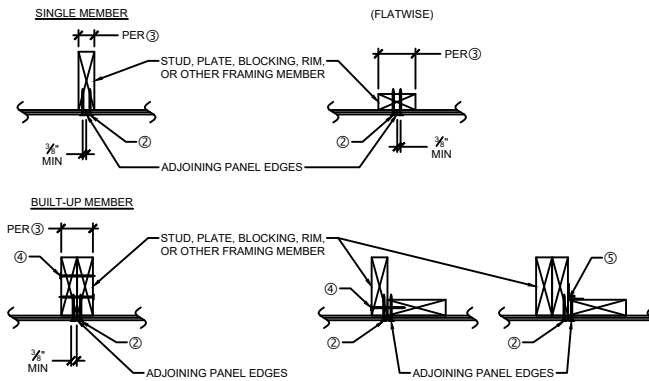

- ④ FACE NAILING APPLIES TO CONDITIONS WHERE FRAMING NAILS CAN BE STRAIGHT DRIVEN THRU FIRST MEMBER AND PENETRATE MAIN MEMBER MINIMUM OF 1/4". FRAMING NAILS SHALL BE 0.131"Ø x 3 1/4". 0.131"Ø x 3" NAILS MAY BE USED WHEN STITCHING TOGETHER (2)2x MEMBERS WITH NO SPACERS.
- ⑤ AT ADJOINING PANEL EDGES WHERE SHEATHING CANNOT LAP ON SINGLE MEMBER AND FACE NAILING CANNOT BE ACCOMPLISHED, FRAMING CLIPS SHALL BE USED TO FASTEN BUILT-UP MEMBERS. USE 0.131"Ø x 2 1/2" NAILS AT LTP4 CLIP WHEN INSTALLED OVER 1/2" SHEATHING.

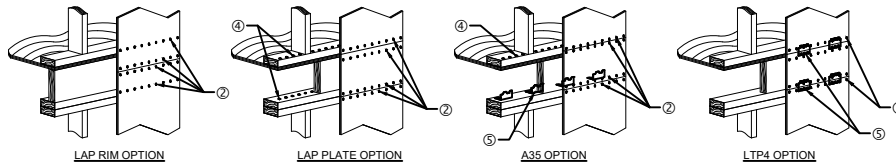

- ⑥ (SECTION 4.3.6.4.3)
ANCHOR BOLTS EMBEDMENT SHALL BE 7". U.O.N. ALL ANCHORS SHALL HAVE 3" x 3" x 0.229" PLATE WASHERS. PLATE WASHER SHALL EXTEND TO WITHIN 1/2" OF THE EDGE OF THE BOTTOM PLATE ON THE SIDE WITH SHEATHING. IF SHEATHING IS ON BOTH SIDES OF THE WALL, STAGGER THE ANCHOR BOLTS. AS REQUIRED, SO THAT HALF OF THE PLATE WASHERS ARE WITHIN 1/2" OF THE EDGE OF THE BOTTOM PLATE ON EACH SIDE. HOLE IN PLATE WASHERS MAY BE DIAGONALLY SLOTTED.

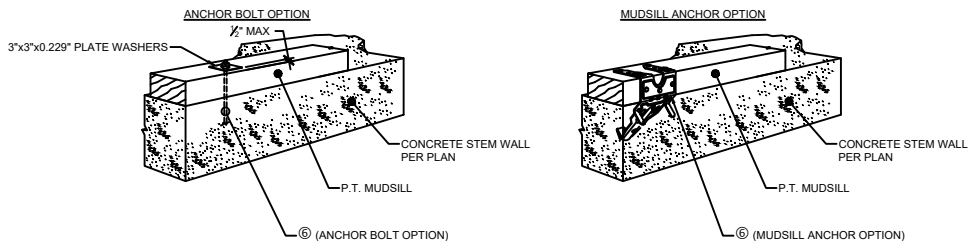

BTL

ENGINEERING

19011 Wood-Sno Road NE, Suite 100

Woodinville, WA 98072-4436

Phone: (425) 814-8448

Fax: (425) 821-2120

Miscellaneous

Stud Wall Design

Based on 2018 NDS Combined axial and bending formula:

$$[f_c/F_c']^2 + f_b/F_b'[1-(f_c/F_{cE})] < 1 \quad \text{in which: } F_{cE} = 0.822(E_{min}')/(l_e/d)^2$$

Wall: Exterior Walls	Wall Height:	9 ft
No Fire Rating ▼	Desired Stud Spacing:	24 in oc
2x6 ▼	Design Axial Dead Load:	683 plf
SPF Stud ▼	Design Axial Live Load:	960 plf
	Design Axial Snow Load:	538 plf
	Design Lateral Pressure (0.6W):	15 psf
	Deflection Criteria:	L/ 240

STUD CHECK	$l_e/d < 50$	OK
D+0.6W ($C_D = 1.60$)		
$[f_c/F_c']^2 + f_b/F_b'[1-(f_c/F_{cE})] =$	0.53 < 1	OK
$f_c/F_{cE2} + (f_b/F_{bE})^2 =$	0.00 < 1	OK
D+0.75L+0.75(0.6W)+0.75S ($C_D = 1.60$)		
$[f_c/F_c']^2 + f_b/F_b'[1-(f_c/F_{cE})] =$	0.92 < 1	OK
$f_c/F_{cE2} + (f_b/F_{bE})^2 =$	0.00 < 1	OK
D+0.75L+0.75S ($C_D = 1.15$)		
$f_c/F_c' =$	0.72 < 1	OK
D+L ($C_D = 1.0$)		
$f_c/F_c' =$	0.71 < 1	OK
Deflection (No Increase for Load Duration):		
Defl: L/ 240 = 0.45	0.18 < 0.45	OK
SPF Stud 2x6 @ 24 oc		OK

PLATE CRUSHING CHECK ¹		
Checks Crushing for Stud Spacing ²		
No Stress Increase for Load Duration		
Hem Fir Plates:	$f_c/F_{c\perp}' =$	0.87 < 1 OK
Douglas Fir Plates:	$f_c/F_{c\perp}' =$	0.56 < 1 OK

¹ Plate must also be checked for bending.

² Check on crushing only applies to stud spacing. Joists above must also be checked for crushing effect on plate.

Also, no stress increase is allowed due to load duration.

Stud Wall Design

Based on 2018 NDS Combined axial and bending formula:

$$[f_c/F_c']^2 + f_b/F_b'[1-(f_c/F_{cE})] < 1 \quad \text{in which: } F_{cE} = 0.822(E_{min}')/(\ell_e/d)^2$$

Wall: Exterior Walls	Wall Height:	19.25 ft
No Fire Rating ▼	Desired Stud Spacing:	16 in oc
(2)2x6 ▼	Design Axial Dead Load:	323 plf
SPF Stud ▼	Design Axial Live Load:	0 plf
	Design Axial Snow Load:	538 plf
	Design Lateral Pressure (0.6W):	15 psf
	Deflection Criteria:	L/ 180

STUD CHECK	$\ell_e/d < 50$	OK
D+0.6W ($C_D = 1.60$)		
$[f_c/F_c']^2 + f_b/F_b'[1-(f_c/F_{cE})] =$	0.70 < 1	OK
$f_c/F_{cE2} + (f_b/F_{bE})^2 =$	0.00 < 1	OK
D+0.75L+0.75(0.6W)+0.75S ($C_D = 1.60$)		
$[f_c/F_c']^2 + f_b/F_b'[1-(f_c/F_{cE})] =$	0.71 < 1	OK
$f_c/F_{cE2} + (f_b/F_{bE})^2 =$	0.00 < 1	OK
D+0.75L+0.75S ($C_D = 1.15$)		
$f_c/F_c' =$	0.30 < 1	OK
D+L ($C_D = 1.0$)		
$f_c/F_c' =$	0.14 < 1	OK
Deflection (No Increase for Load Duration):		
Defl: L/ 180 = 1.28	1.24 < 1.28	OK
SPF Stud (2)2x6 @ 16 oc		OK

PLATE CRUSHING CHECK ¹		
Checks Crushing for Stud Spacing ²		
No Stress Increase for Load Duration		
Hem Fir Plates:	$f_c/F_{c\perp}' =$	0.13 < 1 OK
Douglas Fir Plates:	$f_c/F_{c\perp}' =$	0.08 < 1 OK

¹ Plate must also be checked for bending.

² Check on crushing only applies to stud spacing. Joists above must also be checked for crushing effect on plate.

Also, no stress increase is allowed due to load duration.

Stud Wall Design

Based on 2018 NDS Combined axial and bending formula:

$$[f_c/F_c']^2 + f_b/F_b'[1-(f_c/F_{cE})] < 1 \quad \text{in which: } F_{cE} = 0.822(E_{min}')/(l_e/d)^2$$

Wall: Interior Walls	Wall Height:	9 ft
No Fire Rating ▼	Desired Stud Spacing:	24 in oc
2x4 ▼	Design Axial Dead Load:	203 plf
SPF Stud ▼	Design Axial Live Load:	540 plf
	Design Axial Snow Load:	0 plf
	Design Lateral Pressure (0.6W):	5 psf
	Deflection Criteria:	L/ 180

STUD CHECK	$l_e/d < 50$	OK
D+0.6W ($C_D = 1.60$)		
$[f_c/F_c']^2 + f_b/F_b'[1-(f_c/F_{cE})] =$	0.41 < 1	OK
$f_c/F_{cE2} + (f_b/F_{bE})^2 =$	0.00 < 1	OK
D+0.75L+0.75(0.6W)+0.75S ($C_D = 1.60$)		
$[f_c/F_c']^2 + f_b/F_b'[1-(f_c/F_{cE})] =$	0.99 < 1	OK
$f_c/F_{cE2} + (f_b/F_{bE})^2 =$	0.00 < 1	OK
D+0.75L+0.75S ($C_D = 1.15$)		
$f_c/F_c' =$	0.69 < 1	OK
D+L ($C_D = 1.0$)		
$f_c/F_c' =$	0.86 < 1	OK
Deflection (No Increase for Load Duration):		
Defl: L/ 180 = 0.60	0.23 < 0.60	OK
SPF Stud 2x4 @ 24 oc		OK

PLATE CRUSHING CHECK ¹		
Checks Crushing for Stud Spacing ²		
No Stress Increase for Load Duration		
Hem Fir Plates:	$f_c/F_{c\perp}' =$	0.46 < 1 OK
Douglas Fir Plates:	$f_c/F_{c\perp}' =$	0.30 < 1 OK

¹ Plate must also be checked for bending.

² Check on crushing only applies to stud spacing. Joists above must also be checked for crushing effect on plate.

Also, no stress increase is allowed due to load duration.

Stud Wall Design

Based on 2018 NDS Combined axial and bending formula:

$$[f_c/F_c']^2 + f_b/F_b'[1-(f_c/F_{cE})] < 1 \quad \text{in which: } F_{cE} = 0.822(E_{min}')/(\ell_e/d)^2$$

Wall: Interior Walls	Wall Height:	9 ft
No Fire Rating ▼	Desired Stud Spacing:	16 in oc
2x4 ▼	Design Axial Dead Load:	338 plf
SPF Stud ▼	Design Axial Live Load:	900 plf
	Design Axial Snow Load:	0 plf
	Design Lateral Pressure (0.6W):	5 psf
	Deflection Criteria:	L/ 180

STUD CHECK	$\ell_e/d < 50$	OK
D+0.6W ($C_D = 1.60$)		
$[f_c/F_c']^2 + f_b/F_b'[1-(f_c/F_{cE})] =$	0.31 < 1	OK
$f_c/F_{cE2} + (f_b/F_{bE})^2 =$	0.00 < 1	OK
D+0.75L+0.75(0.6W)+0.75S ($C_D = 1.60$)		
$[f_c/F_c']^2 + f_b/F_b'[1-(f_c/F_{cE})] =$	0.99 < 1	OK
$f_c/F_{cE2} + (f_b/F_{bE})^2 =$	0.00 < 1	OK
D+0.75L+0.75S ($C_D = 1.15$)		
$f_c/F_c' =$	0.76 < 1	OK
D+L ($C_D = 1.0$)		
$f_c/F_c' =$	0.95 < 1	OK
Deflection (No Increase for Load Duration):		
Defl: L/ 180 = 0.60	0.15 < 0.60	OK
SPF Stud 2x4 @ 16 oc		OK

PLATE CRUSHING CHECK ¹		
Checks Crushing for Stud Spacing ²		
No Stress Increase for Load Duration		
Hem Fir Plates:	$f_c/F_{c\perp}' =$	0.51 < 1 OK
Douglas Fir Plates:	$f_c/F_{c\perp}' =$	0.33 < 1 OK

¹ Plate must also be checked for bending.

² Check on crushing only applies to stud spacing. Joists above must also be checked for crushing effect on plate.

Also, no stress increase is allowed due to load duration.

2018 NDS

3.7-SOLID COLUMNS and 15.3-BUILT-UP COLUMNS

Solid Column	▼	$F_c = 800$ psi	$E_{min} = 440$ ksi
Visually graded lumber (Dimensional)	▼	$C_D = 1.00$	$E_{min}' = 440$ ksi
No Fire Rating	▼	$C_M = 1.00$	$l = 9.0$ ft
Hem-Fir Stud	▼	$C_t = 1.00$	$d = 5 \frac{1}{2}$ in
		$C_F = 1.00$	$K_e = 1.0$
			$l_e = 108.0$ in
			$l_e/d = 19.6$

$$F_c' = F_c^* C_p$$

$$F_c^* = F_c C_D C_M C_t C_F$$

$$F_c^* = 800 \text{ psi}$$

$$C_p = 0.743$$

$$F_c' = 594 \text{ psi}$$

$$C_p = K_f \left[\frac{1 + \left(\frac{F_{cE}}{F_c^*} \right)}{2c} - \sqrt{\left[\frac{1 + \left(\frac{F_{cE}}{F_c^*} \right)}{2c} \right]^2 - \frac{F_{cE}/F_c^*}{c}} \right]$$

$$F_{cE} = 938$$

$$F_{cE} = \frac{0.822 E_{min}'}{\left(l_e/d \right)^2}$$

$$c = 0.8$$

$$K_f = 1.0$$

	<u>STUD</u>	<u>HF Plate Crushing</u>	<u>DF Plate Crushing</u>
(1) 2x6	4904	3341	5156
(2) 2x6	9807	6683	10313
(3) 2x6	14711	10024	15469
(4) 2x6	19614	13365	20625
(5) 2x6	24518	16706	25781

2018 NDS

3.7-SOLID COLUMNS and 15.3-BUILT-UP COLUMNS

Solid Column	▼	$F_c = 800$ psi	$E_{min} = 440$ ksi
Visually graded lumber (Dimensional)	▼	$C_D = 1.00$	$E_{min}' = 440$ ksi
No Fire Rating	▼	$C_M = 1.00$	$l = 9.0$ ft
Hem-Fir Stud	▼	$C_t = 1.00$	$d = 3 \frac{1}{2}$ in
		$C_F = 1.00$	$K_e = 1.0$
			$l_e = 108.0$ in
			$l_e/d = 30.9$

$$F_c' = F_c^* C_p$$

$$F_c^* = F_c C_D C_M C_t C_F$$

$$F_c^* = 800 \text{ psi}$$

$$C_p = 0.416$$

$$F_c' = 333 \text{ psi}$$

$$C_p = K_f \left[\frac{1 + \left(\frac{F_{cE}}{F_c^*} \right)}{2c} - \sqrt{\left[\frac{1 + \left(\frac{F_{cE}}{F_c^*} \right)}{2c} \right]^2 - \frac{F_{cE}}{F_c^*}} \right]$$

$$F_{cE} = 380$$

$$F_{cE} = \frac{0.822 E_{min}'}{\left(l_e/d \right)^2}$$

$$c = 0.8$$

$$K_f = 1.0$$

	<u>STUD</u>	<u>HF Plate Crushing</u>	<u>DF Plate Crushing</u>
(1) 2x4	1746	2126	3281
(2) 2x4	3492	4253	6563
(3) 2x4	5237	6379	9844
(4) 2x4	6983	8505	13125
(5) 2x4	8729	10631	16406

Project: **Continuous Strip Footing**
18" wide x 8" thick

IBC Section 13.3.2: One-way shallow foundations

Footing width, $B =$ 18 in
 Footing Thickness, $t =$ 8 in
 Stem Wall width, $C =$ 8 in
 Stem Wall Height = 24 in

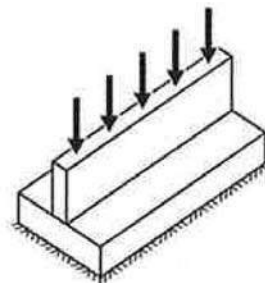

Strip footing

Normalweight $f'_c =$ 2500 psi
 Uncoated $f_y =$ 40000 psi
 Longitudinal Reinforcement: (2) #4
 Bar Diameter = 0.500 in
 Bar Area = 0.20 in²
 $A_s =$ 0.40 in²

Cover: 3 in
 Stem Wall Reinforcement: #4 @ 24" oc Straight Dowels
 Bar Diameter = 0.500 in
 Bar Area = 0.20 in²
 $A_s =$ 0.00 in²
 Cover: 3 in
 $b_w =$ 12 in (per ft)
 $d =$ 4.75 in

Footing + Stem Wall Weight - Weight of Displaced Soil = 240 plf

One-way shear, no shear reinforcement:

[22.5.5.1] $V_c = 2\lambda\sqrt{f'_c}b_wd =$ 5700 # per foot length $\phi =$ 0.75

[22.5.10.1] $V_u \leq \phi V_c$

$$V_u = q_u b_w \left(\frac{B-C}{2} - d \right) \rightarrow q_u = \frac{\phi V_c}{b_w \left(\frac{B-C}{2} - d \right)}$$

Max Uniform Load on Stem = 51300 psf [Ultimate]
 76950 plf [Service]
 48094 plf [Service]

Moment:

[22.2.1.1] $M_n = A_s f_y (d - a/2) =$ 0.000 k-ft per foot length $\phi =$ 0.90

$$M_u \leq \phi M_n$$

$$M_u = \frac{q_u b_w \left(\frac{B-C}{2} \right)^2}{2} \rightarrow q_u = \frac{2\phi M_n}{b_w \left(\frac{B-C}{2} \right)^2}$$

$a = \frac{A_s f_y}{0.85 f'_c b} =$ 0.00 in

Max Uniform Load on Stem = 12000 plf [Ultimate]
 7500 plf [Service]

Development of Reinforcement:

[25.4.2.3] $l_d = \left(\frac{3}{40} \frac{f_y}{\lambda \sqrt{f'_c}} \frac{\psi_t \psi_e \psi_s}{\left(\frac{c_b + K_{tr}}{d_b} \right)} \right) d_b =$ N/A

OK

Allowable Soil Bearing Pressure

Max Uniform Load, Soil	1500 psf	2000 psf	2500 psf	3000 psf	3500 psf	4000 psf
Max Uniform Load, Shear	2010 plf	2760 plf	3510 plf	4260 plf	5010 plf	5760 plf
Max Uniform Load, Moment	48094 plf	48094 plf	48094 plf	48094 plf	48094 plf	48094 plf
Max Uniform Load (Service)	7500 plf	7500 plf	7500 plf	7500 plf	7500 plf	7500 plf
Max Uniform Load (Ultimate)	2010 plf	2760 plf	3510 plf	4260 plf	5010 plf	5760 plf
	3216 plf	4416 plf	5616 plf	6816 plf	8016 plf	9216 plf
Max Point Load (Service)	16080 #	22080 #	28080 #	34080 #	40080 #	46080 #
Max Point Load (Ultimate)	25728 #	35328 #	44928 #	54528 #	64128 #	73728 #

Project: **Typical Footing**
 Footing: **18" x 18" x 8" thick**

Footing $B = 1.50$ ft
 $t = 8$ in
 Reinforcement $R = (2)$ #4
 $A_{s1} = 0.40$ in²
 $d = 4.25$ in Cover: **3 in**
 Column $C_1 = 3.50$ in $C_2 = 3.50$ in
 Materials $f'_c = 2500$ psi Normalweight $\lambda = 1.00$
 $f_y = 40000$ psi Uncoated $\psi_e = 1.00$

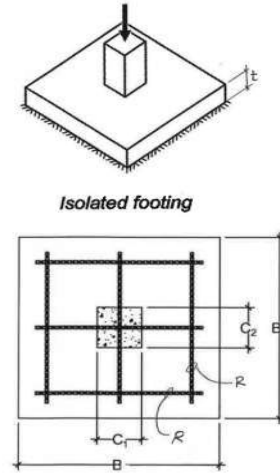

Net Footing Weight
 $P_{FTG} = 0.06$ k

Soil Pressure:
 $P_{ASD} = q_a B^2 - P_{FTG} =$

One-way shear: $\phi = 0.75$
 $V_c = 2\lambda\sqrt{f'_c}Bd = 7.65$ k
 $V_u \leq \phi V_c$ $\phi V_c = 5.74$ k
 $V_u = q_u B \left(\frac{B - C_2}{2} - d \right) \rightarrow q_u = \frac{\phi V_c}{B \left(\frac{B - C_2}{2} - d \right)}$
 $q_u = 15300$ psf or 15300 psf
 $P_u = q_u B^2 = 34425$ #

Two-way shear: $\phi = 0.75$
 [22.6.5.2(a)] $v_c = 4\lambda\sqrt{f'_c} = 200$ psi \Leftarrow
 [22.6.5.2(b)] $v_c = \left(2 + \frac{4}{\beta} \right) \lambda\sqrt{f'_c} = 300$ psi $\beta = 1.00$
 [22.6.5.2(c)] $v_c = \left(2 + \frac{\alpha_x d}{b_o} \right) \lambda\sqrt{f'_c} = 374$ psi $\alpha_x = 40$
 $V_u \leq \phi V_c$ $\phi V_c = \phi v_c b_o d = 19.76$ k $b_o = 2(C_1 + d) + 2(C_2 + d) = 31$
 $V_u = q_u [B^2 - (C_1 + d)(C_2 + d)] \rightarrow q_u = \frac{\phi V_c}{[B^2 - (C_1 + d)(C_2 + d)]}$
 $q_u = 10782$ psf $P_u = q_u B^2 = 24260$ #

Moment: $\phi = 0.90$
 $M_n = A_s f_y \left(d - \frac{a}{2} \right) = 5.4$ k-ft
 $a = A_s f_y / (0.85 f'_c B) = 0.42$ in
 $M_u \leq \phi M_n$ $\phi M_n = 4.8$ k-ft
 $M_u = \frac{q_u B \left(\frac{B - C_2}{2} \right)^2}{2} \rightarrow q_u = \frac{2\phi M_n}{B \left(\frac{B - C_2}{2} \right)^2}$
 $q_u = 17712$ psf or 17712 psf
 $M_u = \frac{q_u B \left(\frac{B - C_1}{2} \right)^2}{2} \rightarrow q_u = \frac{2\phi M_n}{B \left(\frac{B - C_1}{2} \right)^2}$
 $P_u = q_u B^2 = 39853$ #

Development of Reinforcement:

$l_d = \left(\frac{3}{40} \frac{f_y}{\lambda\sqrt{f'_c}} \frac{\psi_t \psi_e \psi_s}{\left(\frac{c_b + K_{tr}}{d_b} \right)} \right) d_b = 4$ in ...4 in available **OK**
 Adjusted

Soil Bearing Pressure	1500 psf	2000 psf	2500 psf	3000 psf	3500 psf	4000 psf
Max Load (lbs), Soil	3315	4440	5565	6690	7815	8940
Max Load (lbs), One-Way Shear	21516	21516	21516	21516	21516	21516
Max Load (lbs), Two-Way Shear	15162	15162	15162	15162	15162	15162
Max Load (lbs), Moment	24908	24908	24908	24908	24908	24908
Max Load (ASD)	3315	4440	5565	6690	7815	8940
Max Load (Factored)	5304	7104	8904	10704	12504	14304

Project: **Typical Footing**
 Footing: **24" x 24" x 8" thick**

Footing $B = 2.00$ ft
 $t = 8$ in
 Reinforcement $R = (2)$ #4
 $A_{s1} = 0.40$ in²
 $d = 4.25$ in
 Column $C_1 = 3.50$ in $C_2 = 3.50$ in
 Materials $f'_c = 2500$ psi Normalweight $\lambda = 1.00$
 $f_y = 40000$ psi Uncoated $\psi_e = 1.00$

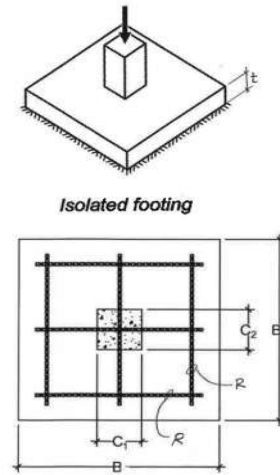

Net Footing Weight
 $P_{FTG} = 0.11$ k

Soil Pressure:
 $P_{ASD} = q_a B^2 - P_{FTG} =$

One-way shear: $\phi = 0.75$

$$V_c = 2\lambda\sqrt{f'_c}Bd = 10.20 \text{ k}$$

$$V_u \leq \phi V_c \quad \phi V_c = 7.65 \text{ k}$$

$$V_u = q_u B \left(\frac{B - C_2}{2} - d \right) \rightarrow q_u = \frac{\phi V_c}{B \left(\frac{B - C_2}{2} - d \right)}$$

$$q_u = 7650 \text{ psf} \quad \text{or} \quad 7650 \text{ psf}$$

$$V_u = q_u B \left(\frac{B - C_1}{2} - d \right) \rightarrow q_u = \frac{\phi V_c}{B \left(\frac{B - C_1}{2} - d \right)}$$

$$P_u = q_u B^2 = 30600 \#$$

Two-way shear: $\phi = 0.75$

[22.6.5.2(a)] $v_c = 4\lambda\sqrt{f'_c} = 200$ psi \Leftarrow

[22.6.5.2(b)] $v_c = \left(2 + \frac{4}{\beta} \right) \lambda\sqrt{f'_c} = 300$ psi

[22.6.5.2(c)] $v_c = \left(2 + \frac{\alpha_x d}{b_0} \right) \lambda\sqrt{f'_c} = 374$ psi

$V_u \leq \phi V_c \quad \phi V_c = \phi v_c b_0 d = 19.76$ k

$\beta = 1.00$
 $\alpha_x = 40$
 $b_0 = 2(C_1 + d) + 2(C_2 + d) = 31$

$$V_u = q_u [B^2 - (C_1 + d)(C_2 + d)] \rightarrow q_u = \frac{\phi V_c}{[B^2 - (C_1 + d)(C_2 + d)]}$$

$$q_u = 5516 \text{ psf} \quad P_u = q_u B^2 = 22063 \#$$

Moment: $\phi = 0.90$

$M_n = A_s f_y \left(d - \frac{a}{2} \right) = 5.5$ k-ft

$a = A_s f_y / (0.85 f'_c B) = 0.31$ in

$M_u \leq \phi M_n \quad \phi M_n = 4.9$ k-ft

$$M_u = \frac{q_u B \left(\frac{B - C_2}{2} \right)^2}{2} \rightarrow q_u = \frac{2\phi M_n}{B \left(\frac{B - C_2}{2} \right)^2}$$

$$q_u = 6732 \text{ psf} \quad \text{or} \quad 6732 \text{ psf}$$

$$M_u = \frac{q_u B \left(\frac{B - C_1}{2} \right)^2}{2} \rightarrow q_u = \frac{2\phi M_n}{B \left(\frac{B - C_1}{2} \right)^2}$$

$$P_u = q_u B^2 = 26929 \#$$

Development of Reinforcement:

$$l_d = \left(\frac{3}{40} \frac{f_y}{\lambda\sqrt{f'_c}} \frac{\psi_t \psi_e \psi_s}{\left(\frac{c_b + K_{tr}}{d_b} \right)} \right) d_b = 7 \text{ in} \quad \dots 7 \text{ in available} \quad \text{OK}$$

Adjusted

Soil Bearing Pressure	1500 psf	2000 psf	2500 psf	3000 psf	3500 psf	4000 psf
Max Load (lbs), Soil	5893	7893	9893	11893	13893	15893
Max Load (lbs), One-Way Shear	19125	19125	19125	19125	19125	19125
Max Load (lbs), Two-Way Shear	13789	13789	13789	13789	13789	13789
Max Load (lbs), Moment	16830	16830	16830	16830	16830	16830
Max Load (ASD)	5893	7893	9893	11893	12710	12710
Max Load (Factored)	9429	12629	15829	19029	20337	20337

Project: **Typical Footing**
Footing: **30" x 30" x 8" thick**

Footing $B = 2.50 \text{ ft}$
 $t = 8 \text{ in}$

Reinforcement $R = (3) \#4$
 $A_{s1} = 0.60 \text{ in}^2$
 $d = 4.25 \text{ in}$ Cover: **3 in**

Column $C_1 = 3.50 \text{ in}$ $C_2 = 3.50 \text{ in}$

Materials $f'_c = 2500 \text{ psi}$ Normalweight $\lambda = 1.00$
 $f_y = 40000 \text{ psi}$ Uncoated $\psi_e = 1.00$

Net Footing Weight
 $P_{FTG} = 0.17 \text{ k}$

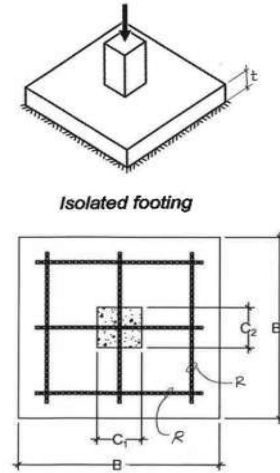

Soil Pressure:

$$P_{ASD} = q_a B^2 - P_{FTG} =$$

One-way shear: $\phi = 0.75$

$$V_c = 2\lambda\sqrt{f'_c}Bd = 12.75 \text{ k}$$

$$V_u \leq \phi V_c \quad \phi V_c = 9.56 \text{ k}$$

$$V_u = q_u B \left(\frac{B - C_2}{2} - d \right) \rightarrow q_u = \frac{\phi V_c}{B \left(\frac{B - C_2}{2} - d \right)}$$

$$q_u = 5100 \text{ psf} \quad \text{or}$$

$$5100 \text{ psf}$$

$$V_u = q_u B \left(\frac{B - C_1}{2} - d \right) \rightarrow q_u = \frac{\phi V_c}{B \left(\frac{B - C_1}{2} - d \right)}$$

$$P_u = q_u B^2 = 31875 \#$$

Two-way shear: $\phi = 0.75$

$$[22.6.5.2(a)] \quad v_c = 4\lambda\sqrt{f'_c} = 200 \text{ psi} \quad \Leftarrow$$

$$[22.6.5.2(b)] \quad v_c = \left(2 + \frac{4}{\beta} \right) \lambda\sqrt{f'_c} = 300 \text{ psi}$$

$$[22.6.5.2(c)] \quad v_c = \left(2 + \frac{\alpha_x d}{b_0} \right) \lambda\sqrt{f'_c} = 374 \text{ psi}$$

$$V_u \leq \phi V_c \quad \phi V_c = \phi v_c b_0 d = 19.76 \text{ k}$$

$$V_u = q_u [B^2 - (C_1 + d)(C_2 + d)] \rightarrow q_u = \frac{\phi V_c}{[B^2 - (C_1 + d)(C_2 + d)]}$$

$$q_u = 3388 \text{ psf}$$

$$P_u = q_u B^2 = 21176 \#$$

Moment: $\phi = 0.90$

$$M_n = A_s f_y \left(d - \frac{a}{2} \right) = 8.1 \text{ k-ft}$$

$$a = A_s f_y / (0.85 f'_c B) = 0.38 \text{ in}$$

$$M_u \leq \phi M_n \quad \phi M_n = 7.3 \text{ k-ft}$$

$$M_u = \frac{q_u B \left(\frac{B - C_2}{2} \right)^2}{2} \rightarrow q_u = \frac{2\phi M_n}{B \left(\frac{B - C_2}{2} \right)^2}$$

$$q_u = 4797 \text{ psf} \quad \text{or}$$

$$4797 \text{ psf}$$

$$M_u = \frac{q_u B \left(\frac{B - C_1}{2} \right)^2}{2} \rightarrow q_u = \frac{2\phi M_n}{B \left(\frac{B - C_1}{2} \right)^2}$$

$$P_u = q_u B^2 = 29984 \#$$

Development of Reinforcement:

$$l_d = \left(\frac{3}{40} \frac{f_y}{\lambda\sqrt{f'_c}} \frac{\psi_t \psi_e \psi_s}{\left(\frac{c_b + K_{tr}}{d_b} \right)} \right) d_b = 10 \text{ in} \quad \dots 10 \text{ in available} \quad \text{OK}$$

Soil Bearing Pressure

	1500 psf	2000 psf	2500 psf	3000 psf	3500 psf	4000 psf
Max Load (lbs), Soil	9208	12333	15458	18583	21708	24833
Max Load (lbs), One-Way Shear	19922	19922	19922	19922	19922	19922
Max Load (lbs), Two-Way Shear	13235	13235	13235	13235	13235	13235
Max Load (lbs), Moment	18740	18740	18740	18740	18740	18740
Max Load (ASD)	9208	12333	13235	13235	13235	13235
Max Load (Factored)	14733	19733	21176	21176	21176	21176

Project: **Typical Footing**
Footing: **36" x 36" x 12" thick**

Footing $B = 3.00 \text{ ft}$
 $t = 12 \text{ in}$

Reinforcement $R = (3) \#4$ ▼
 $A_{s1} = 0.60 \text{ in}^2$
 $d = 8.25 \text{ in}$ Cover: **3 in**

Column $C_1 = 5.50 \text{ in}$ $C_2 = 5.50 \text{ in}$

Materials $f'_c = 2500 \text{ psi}$ Normalweight ▼ $\lambda = 1.00$
 $f_y = 40000 \text{ psi}$ Uncoated ▼ $\psi_e = 1.00$

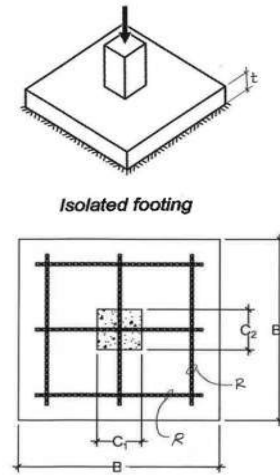

Net Footing Weight
 $P_{FTG} = 0.36 \text{ k}$

Soil Pressure:
 $P_{ASD} = q_a B^2 - P_{FTG} =$

One-way shear: $\phi = 0.75$
 $V_c = 2\lambda\sqrt{f'_c}Bd = 29.70 \text{ k}$
 $V_u \leq \phi V_c$ $\phi V_c = 22.28 \text{ k}$

$$V_u = q_u B \left(\frac{B - C_2}{2} - d \right) \rightarrow q_u = \frac{\phi V_c}{B \left(\frac{B - C_2}{2} - d \right)}$$

$$q_u = 12729 \text{ psf} \quad \text{or} \quad 12729 \text{ psf}$$

$$V_u = q_u B \left(\frac{B - C_1}{2} - d \right) \rightarrow q_u = \frac{\phi V_c}{B \left(\frac{B - C_1}{2} - d \right)}$$

$$P_u = q_u B^2 = 114557 \#$$

Two-way shear: $\phi = 0.75$
[22.6.5.2(a)] $v_c = 4\lambda\sqrt{f'_c} = 200 \text{ psi} \leftarrow$
[22.6.5.2(b)] $v_c = \left(2 + \frac{4}{\beta} \right) \lambda\sqrt{f'_c} = 300 \text{ psi}$ $\beta = 1.00$
[22.6.5.2(c)] $v_c = \left(2 + \frac{\alpha_x d}{b_o} \right) \lambda\sqrt{f'_c} = 400 \text{ psi}$ $\alpha_x = 40$
 $V_u \leq \phi V_c$ $\phi V_c = \phi v_c b_o d = 68.06 \text{ k}$ $b_o = 2(C_1 + d) + 2(C_2 + d) = 55$

$$V_u = q_u [B^2 - (C_1 + d)(C_2 + d)] \rightarrow q_u = \frac{\phi V_c}{[B^2 - (C_1 + d)(C_2 + d)]}$$

$$q_u = 8854 \text{ psf} \quad \text{or} \quad P_u = q_u B^2 = 79687 \#$$

Moment: $\phi = 0.90$
 $M_n = A_s f_y (d - a/2) = 16.2 \text{ k-ft}$
 $a = A_s f_y / (0.85 f'_c B) = 0.31 \text{ in}$
 $M_u \leq \phi M_n$ $\phi M_n = 14.6 \text{ k-ft}$

$$M_u = \frac{q_u B \left(\frac{B - C_2}{2} \right)^2}{2} \rightarrow q_u = \frac{2\phi M_n}{B \left(\frac{B - C_2}{2} \right)^2}$$

$$q_u = 6013 \text{ psf} \quad \text{or} \quad 6013 \text{ psf}$$

$$M_u = \frac{q_u B \left(\frac{B - C_1}{2} \right)^2}{2} \rightarrow q_u = \frac{2\phi M_n}{B \left(\frac{B - C_1}{2} \right)^2}$$

$$P_u = q_u B^2 = 54121 \#$$

Development of Reinforcement:

$$l_d = \left(\frac{3}{40} \frac{f_y}{\lambda\sqrt{f'_c}} \frac{\psi_t \psi_e \psi_s}{\left(\frac{c_b + K_{tr}}{d_b} \right)} \right) d_b = 12 \text{ in} \quad \dots 12 \text{ in available} \quad \text{OK}$$

Soil Bearing Pressure	1500 psf	2000 psf	2500 psf	3000 psf	3500 psf	4000 psf
Max Load (lbs), Soil	13140	17640	22140	26640	31140	35640
Max Load (lbs), One-Way Shear	71598	71598	71598	71598	71598	71598
Max Load (lbs), Two-Way Shear	49805	49805	49805	49805	49805	49805
Max Load (lbs), Moment	33825	33825	33825	33825	33825	33825
Max Load (ASD)	13140	17640	22140	26640	31140	33825
Max Load (Factored)	21024	28224	35424	42624	49824	54121

Project: **Typical Footing**
Footing: **42" x 42" x 12" thick**

Footing $B = 3.50$ ft
 $t = 12$ in

Reinforcement $R = (4)$ #4 ∇
 $A_{s1} = 0.80$ in²
 $d = 8.25$ in Cover: **3 in**

Column $C_1 = 5.50$ in $C_2 = 5.50$ in

Materials $f'_c = 2500$ psi Normalweight ∇ $\lambda = 1.00$
 $f_y = 40000$ psi Uncoated ∇ $\psi_e = 1.00$

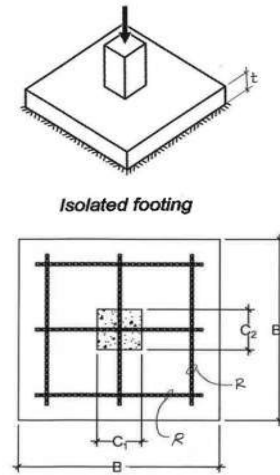

Net Footing Weight
 $P_{FTG} = 0.49$ k

Soil Pressure:
 $P_{ASD} = q_a B^2 - P_{FTG} =$

One-way shear: $\phi = 0.75$
 $V_c = 2\lambda\sqrt{f'_c}Bd = 34.65$ k
 $V_u \leq \phi V_c$ $\phi V_c = 25.99$ k

$$V_u = q_u B \left(\frac{B - C_2}{2} - d \right) \rightarrow q_u = \frac{\phi V_c}{B \left(\frac{B - C_2}{2} - d \right)}$$

$$q_u = 8910 \text{ psf} \quad \text{or} \quad 8910 \text{ psf} \quad P_u = q_u B^2 = 109148 \#$$

Two-way shear: $\phi = 0.75$
[22.6.5.2(a)] $v_c = 4\lambda\sqrt{f'_c} = 200$ psi \Leftarrow
[22.6.5.2(b)] $v_c = \left(2 + \frac{4}{\beta} \right) \lambda\sqrt{f'_c} = 300$ psi $\beta = 1.00$
[22.6.5.2(c)] $v_c = \left(2 + \frac{\alpha_x d}{b_o} \right) \lambda\sqrt{f'_c} = 400$ psi $\alpha_x = 40$
 $V_u \leq \phi V_c$ $\phi V_c = \phi v_c b_o d = 68.06$ k $b_o = 2(C_1 + d) + 2(C_2 + d) = 55$

$$V_u = q_u [B^2 - (C_1 + d)(C_2 + d)] \rightarrow q_u = \frac{\phi V_c}{[B^2 - (C_1 + d)(C_2 + d)]}$$

$$q_u = 6223 \text{ psf} \quad P_u = q_u B^2 = 76233 \#$$

Moment: $\phi = 0.90$
 $M_n = A_s f_y (d - a/2) = 21.5$ k-ft
 $a = A_s f_y / (0.85 f'_c B) = 0.36$ in
 $M_u \leq \phi M_n$ $\phi M_n = 19.4$ k-ft

$$M_u = \frac{q_u B \left(\frac{B - C_2}{2} \right)^2}{2} \rightarrow q_u = \frac{2\phi M_n}{B \left(\frac{B - C_2}{2} \right)^2}$$

$$q_u = 4785 \text{ psf} \quad \text{or} \quad 4785 \text{ psf} \quad P_u = q_u B^2 = 58622 \#$$

Development of Reinforcement:
 $l_d = \left(\frac{3}{40} \frac{f_y}{\lambda\sqrt{f'_c}} \frac{\psi_t \psi_e \psi_s}{\left(\frac{c_b + K_{tr}}{d_b} \right)} \right) d_b = 12$ in ...15 in available **OK**

Soil Bearing Pressure	1500 psf	2000 psf	2500 psf	3000 psf	3500 psf	4000 psf
Max Load (lbs), Soil	17885	24010	30135	36260	42385	48510
Max Load (lbs), One-Way Shear	68217	68217	68217	68217	68217	68217
Max Load (lbs), Two-Way Shear	47646	47646	47646	47646	47646	47646
Max Load (lbs), Moment	36639	36639	36639	36639	36639	36639
Max Load (ASD)	17885	24010	30135	36260	36639	36639
Max Load (Factored)	28616	38416	48216	58016	58622	58622

Project: **Typical Footing**
 Footing: **48" x 48" x 12" thick**

Footing $B = 4.00 \text{ ft}$
 $t = 12 \text{ in}$
 Reinforcement $R = (5) \#4$
 $A_{s1} = 1.00 \text{ in}^2$
 $d = 8.25 \text{ in}$ Cover: **3 in**
 Column $C_1 = 5.50 \text{ in}$ $C_2 = 5.50 \text{ in}$
 Materials $f'_c = 2500 \text{ psi}$ Normalweight $\lambda = 1.00$
 $f_y = 40000 \text{ psi}$ Uncoated $\psi_e = 1.00$

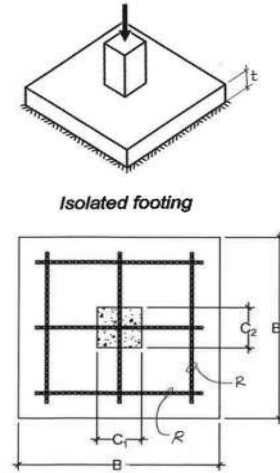

Net Footing Weight
 $P_{FTG} = 0.64 \text{ k}$

Soil Pressure:
 $P_{ASD} = q_a B^2 - P_{FTG} =$

One-way shear: $\phi = 0.75$

$$V_c = 2\lambda\sqrt{f'_c}Bd = 39.60 \text{ k}$$

$$V_u \leq \phi V_c \quad \phi V_c = 29.70 \text{ k}$$

$$V_u = q_u B \left(\frac{B - C_2}{2} - d \right) \rightarrow q_u = \frac{\phi V_c}{B \left(\frac{B - C_2}{2} - d \right)}$$

$$q_u = 6854 \text{ psf} \quad \text{or}$$

$$V_u = q_u B \left(\frac{B - C_1}{2} - d \right) \rightarrow q_u = \frac{\phi V_c}{B \left(\frac{B - C_1}{2} - d \right)}$$

$$q_u = 6854 \text{ psf} \quad P_u = q_u B^2 = 109662 \#$$

Two-way shear: $\phi = 0.75$

[22.6.5.2(a)] $v_c = 4\lambda\sqrt{f'_c} = 200 \text{ psi} \leftarrow$

[22.6.5.2(b)] $v_c = \left(2 + \frac{4}{\beta} \right) \lambda\sqrt{f'_c} = 300 \text{ psi}$

[22.6.5.2(c)] $v_c = \left(2 + \frac{\alpha_x d}{b_0} \right) \lambda\sqrt{f'_c} = 400 \text{ psi}$

$V_u \leq \phi V_c \quad \phi V_c = \phi v_c b_0 d = 68.06 \text{ k}$

$\beta = 1.00$
 $\alpha_x = 40$
 $b_0 = 2(C_1 + d) + 2(C_2 + d) = 55$

$$V_u = q_u [B^2 - (C_1 + d)(C_2 + d)] \rightarrow q_u = \frac{\phi V_c}{[B^2 - (C_1 + d)(C_2 + d)]}$$

$$q_u = 4634 \text{ psf} \quad P_u = q_u B^2 = 74147 \#$$

Moment: $\phi = 0.90$

$M_n = A_s f_y (d - a/2) = 26.8 \text{ k-ft}$

$a = A_s f_y / (0.85 f'_c B) = 0.39 \text{ in}$

$M_u \leq \phi M_n \quad \phi M_n = 24.2 \text{ k-ft}$

$$M_u = \frac{q_u B \left(\frac{B - C_2}{2} \right)^2}{2} \rightarrow q_u = \frac{2\phi M_n}{B \left(\frac{B - C_2}{2} \right)^2}$$

$$q_u = 3853 \text{ psf} \quad \text{or}$$

$$M_u = \frac{q_u B \left(\frac{B - C_1}{2} \right)^2}{2} \rightarrow q_u = \frac{2\phi M_n}{B \left(\frac{B - C_1}{2} \right)^2}$$

$$q_u = 3853 \text{ psf} \quad P_u = q_u B^2 = 61640 \#$$

Development of Reinforcement:

$$l_d = \left(\frac{3}{40} \frac{f_y}{\lambda\sqrt{f'_c}} \frac{\psi_t \psi_e \psi_s}{\left(\frac{c_b + K_{tr}}{d_b} \right)} \right) d_b = 12 \text{ in} \quad \dots 18 \text{ in available} \quad \text{OK}$$

Soil Bearing Pressure	1500 psf	2000 psf	2500 psf	3000 psf	3500 psf	4000 psf
Max Load (lbs), Soil	23360	31360	39360	47360	55360	63360
Max Load (lbs), One-Way Shear	68538	68538	68538	68538	68538	68538
Max Load (lbs), Two-Way Shear	46342	46342	46342	46342	46342	46342
Max Load (lbs), Moment	38525	38525	38525	38525	38525	38525
Max Load (ASD)	23360	31360	38525	38525	38525	38525
Max Load (Factored)	37376	50176	61640	61640	61640	61640